

Tooling by **DIJET**[®] PRODUCT GUIDE

Vol. **5**
2024~2025





- All cutter-holders are supplied without Inserts , Wrench & MOLY.
- Specifications for the products listed in this catalog are subject to change without notice due to replacement or modification.

ABOUT STOCK

- : Stocked Items ○: Stock in JAPAN ◎: Soon to be stocked

CUTTING STYLE ICON



COATING ICON



TYPE OF MACHINING



CORNER SHAPE



OTHERS



G-BODY is a GN surface-hardening treatment on thermal resistant high strength steel giving a hardness over 65HRC and secures insert pocket and holder against thermal deformation improving body durability.



Carbide shank provides much lower deflection than steel shank, that enables maximum tool life and highest productivity.











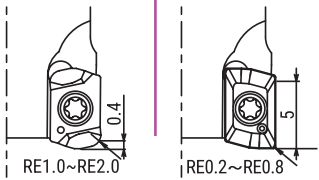

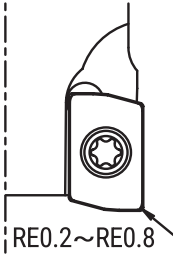
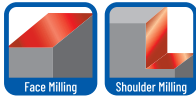

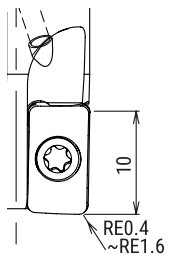
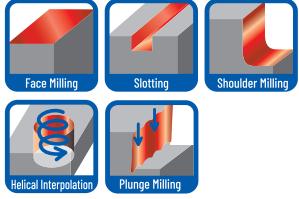
INDEXABLE TOOLS

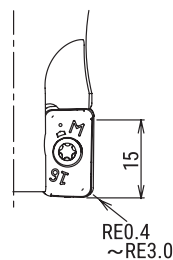

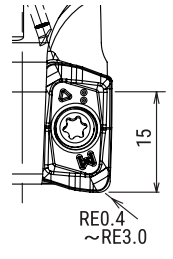

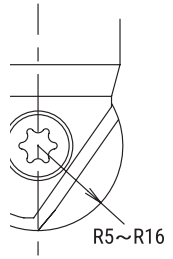





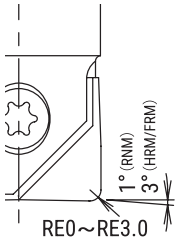





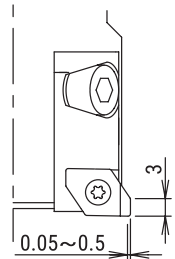



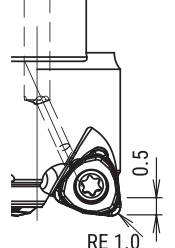



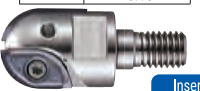
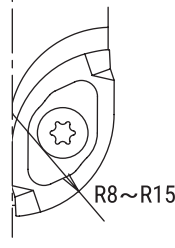











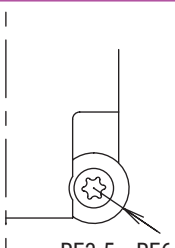







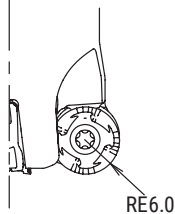





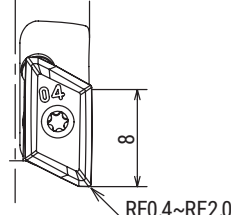





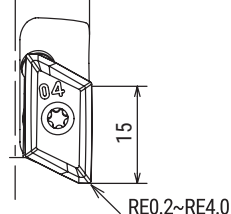







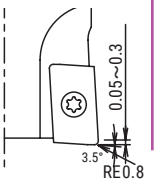
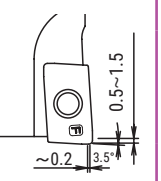





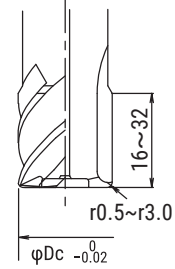

MILLING TOOLS QUICK GUIDE

Type	Item Code	Shape / Tool dia.	Cutting edge angle / Max.DOC	Applications
HIGH FEED COPY MILLING	SKS-GII	<div style="display: flex; justify-content: space-around; align-items: center;"> <div style="border: 1px solid black; padding: 2px;">O.D. Tolerance 0 -0.1</div> <div style="border: 1px solid black; padding: 2px;">Insert N.E.M Class</div> </div> <p style="text-align: center;">φ25~φ42</p>	<p style="text-align: center;">1.5 RE1.5</p>	<div style="display: grid; grid-template-columns: repeat(3, 1fr); gap: 5px;"> <div style="border: 1px solid black; padding: 2px; text-align: center;">Face Milling</div> <div style="border: 1px solid black; padding: 2px; text-align: center;">Pocket Milling</div> <div style="border: 1px solid black; padding: 2px; text-align: center;">Copy Milling</div> <div style="border: 1px solid black; padding: 2px; text-align: center;">Helical Interpolation</div> <div style="border: 1px solid black; padding: 2px; text-align: center;">Plunge Milling</div> <div style="border: 1px solid black; padding: 2px; text-align: center; font-weight: bold;">G- Body</div> </div>
	MSG Type			
	A051			
HIGH FEED COPY MILLING	SKS-GII-09	<div style="display: flex; justify-content: space-around; align-items: center;"> <div style="border: 1px solid black; padding: 2px;">O.D. Tolerance 0 -0.1</div> <div style="border: 1px solid black; padding: 2px;">Insert E Class</div> </div> <p style="text-align: center;">φ20~φ42</p>	<p style="text-align: center;">0.9 RE1.2</p>	<div style="display: grid; grid-template-columns: repeat(3, 1fr); gap: 5px;"> <div style="border: 1px solid black; padding: 2px; text-align: center;">Face Milling</div> <div style="border: 1px solid black; padding: 2px; text-align: center;">Pocket Milling</div> <div style="border: 1px solid black; padding: 2px; text-align: center;">Copy Milling</div> <div style="border: 1px solid black; padding: 2px; text-align: center;">Helical Interpolation</div> <div style="border: 1px solid black; padding: 2px; text-align: center;">Plunge Milling</div> <div style="border: 1px solid black; padding: 2px; text-align: center; font-weight: bold;">G- Body</div> </div>
	MSG-09 Type			
	A064			
HIGH FEED COPY MILLING	SKS EXTREME	<div style="display: flex; justify-content: space-around; align-items: center;"> <div style="border: 1px solid black; padding: 2px;">O.D. Tolerance -0.05 -0.15</div> <div style="border: 1px solid black; padding: 2px;">Insert M Class</div> </div> <p style="text-align: center;">φ32~φ42</p>	<p style="text-align: center;">2 RE2.0</p>	<div style="display: grid; grid-template-columns: repeat(3, 1fr); gap: 5px;"> <div style="border: 1px solid black; padding: 2px; text-align: center;">Face Milling</div> <div style="border: 1px solid black; padding: 2px; text-align: center;">Pocket Milling</div> <div style="border: 1px solid black; padding: 2px; text-align: center;">Copy Milling</div> <div style="border: 1px solid black; padding: 2px; text-align: center;">Helical Interpolation</div> <div style="border: 1px solid black; padding: 2px; text-align: center;">Plunge Milling</div> <div style="border: 1px solid black; padding: 2px; text-align: center; font-weight: bold;">G- Body</div> </div>
	MEX-07 Type			
	A072			
HIGH FEED COPY MILLING	SKS EXTREME	<div style="display: flex; justify-content: space-around; align-items: center;"> <div style="border: 1px solid black; padding: 2px;">O.D. Tolerance -0.05 -0.15</div> <div style="border: 1px solid black; padding: 2px;">Insert M Class</div> </div> <p style="text-align: center;">φ20~φ40</p>	<p style="text-align: center;">1.5 RE2.0</p>	<div style="display: grid; grid-template-columns: repeat(3, 1fr); gap: 5px;"> <div style="border: 1px solid black; padding: 2px; text-align: center;">Face Milling</div> <div style="border: 1px solid black; padding: 2px; text-align: center;">Pocket Milling</div> <div style="border: 1px solid black; padding: 2px; text-align: center;">Copy Milling</div> <div style="border: 1px solid black; padding: 2px; text-align: center;">Helical Interpolation</div> <div style="border: 1px solid black; padding: 2px; text-align: center;">Plunge Milling</div> <div style="border: 1px solid black; padding: 2px; text-align: center; font-weight: bold;">G- Body</div> </div>
	MEX-05 Type			
	A070			
HIGH FEED COPY MILLING	QM MAX GII	<div style="border: 1px solid black; padding: 2px; display: inline-block;">Insert M Class</div> <p style="text-align: center;">φ16~φ42</p>	<p style="text-align: center;">1 RE1.2</p>	<div style="display: grid; grid-template-columns: repeat(3, 1fr); gap: 5px;"> <div style="border: 1px solid black; padding: 2px; text-align: center;">Face Milling</div> <div style="border: 1px solid black; padding: 2px; text-align: center;">Pocket Milling</div> <div style="border: 1px solid black; padding: 2px; text-align: center;">Copy Milling</div> <div style="border: 1px solid black; padding: 2px; text-align: center;">Helical Interpolation</div> <div style="border: 1px solid black; padding: 2px; text-align: center;">Slotting</div> <div style="border: 1px solid black; padding: 2px; text-align: center; font-weight: bold;">G- Body</div> </div>
	MXG Type			
	A085			
HIGH FEED COPY MILLING	QM MAX	<div style="border: 1px solid black; padding: 2px; display: inline-block;">Insert H.M Class</div> <p style="text-align: center;">φ16~φ42</p>	<div style="display: flex; justify-content: space-around;"> <div style="text-align: center;"> <p>High Feed</p> <div style="border: 1px solid black; padding: 2px; display: inline-block;">O.D. Tolerance -0.06 -0.14</div> <p style="text-align: center;">0.8 IRE1.2~RE2.0</p> </div> <div style="text-align: center;"> <p>Shoulder Milling</p> <div style="border: 1px solid black; padding: 2px; display: inline-block;">O.D. Tolerance -0.03 -0.11</div> <p style="text-align: center;">6 IRE0.4~RE2.0</p> </div> </div>	<div style="display: grid; grid-template-columns: repeat(3, 1fr); gap: 5px;"> <div style="border: 1px solid black; padding: 2px; text-align: center;">Face Milling</div> <div style="border: 1px solid black; padding: 2px; text-align: center;">Pocket Milling</div> <div style="border: 1px solid black; padding: 2px; text-align: center;">Copy Milling</div> <div style="border: 1px solid black; padding: 2px; text-align: center;">Helical Interpolation</div> <div style="border: 1px solid black; padding: 2px; text-align: center;">Slotting</div> <div style="border: 1px solid black; padding: 2px; text-align: center;">Shoulder Milling</div> <div style="border: 1px solid black; padding: 2px; text-align: center; font-weight: bold;">G- Body</div> </div>
	MQX Type			
	A095			

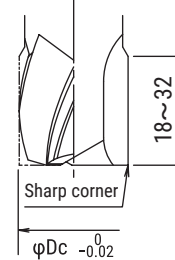







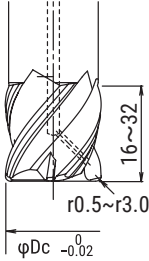

Type	Item Code	Shape / Tool dia.	Cutting edge angle / Max.DOC	Applications
HIGH FEED COPY MILLING	QM MILL	 φ10~φ32	High Feed O.D. Tolerance -0.05 -0.15 Shoulder Milling O.D. Tolerance -0.02 -0.12 	
	MPM Type			
	A109			
SHOULDER MILLING	HIGH PRECISION QM MILL	 φ10~φ16		
	MPT Type			
SHOULDER MILLING	EXTREME SAP	 φ16~φ40		
	MSX-11 Type			
SHOULDER MILLING	EXTREME SAP	 φ25~φ40		
	MSX-17 Type			
SHOULDER MILLING	SIC-EVO	 φ25~φ40		
	SSV Type			
FINISHING COPY MILLING	MIRROR BALL	 φ10~φ30		
	MBX Type			





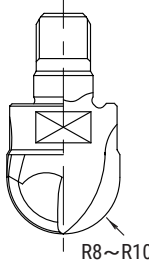



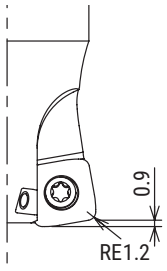
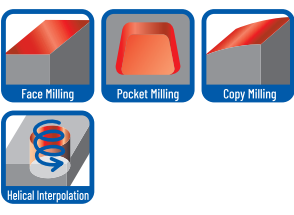

MILLING TOOLS QUICK GUIDE

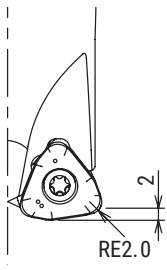
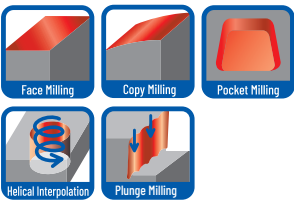
Type	Item Code	Shape / Tool dia.	Cutting edge angle / Max.DOC	Applications									
FINISHING COPY MILLING	MIRROR RADIUS	<table border="1"> <tr> <td>O.D. Tolerance</td> <td>-0.002 -0.018</td> <td>Insert F Class</td> </tr> </table>  <p>φ10~φ32</p>	O.D. Tolerance	-0.002 -0.018	Insert F Class	 <p>1° (RNM) 3° (HRM/FRM) RE0~RE3.0</p>	    						
	O.D. Tolerance	-0.002 -0.018	Insert F Class										
MRX Type	A160												
FINISHING UP & DOWN MILLING	BACK & FORTH CUTTER	<table border="1"> <tr> <td>O.D. Tolerance</td> <td>+0.1 -0.3</td> <td>Insert G Class</td> </tr> </table>  <p>φ30~φ40</p>	O.D. Tolerance	+0.1 -0.3	Insert G Class	 <p>3 0.05~0.5</p>	 	<p>WEB CATALOGUE</p> 					
	O.D. Tolerance	+0.1 -0.3	Insert G Class										
MPF Type	Available only on WEB CATALOGUE												
FINISHING COPY MILLING	DIEMASTER 5G	<table border="1"> <tr> <td>O.D. Tolerance</td> <td>0.0 -0.05</td> <td>Insert H Class</td> </tr> </table>  <p>φ16~φ42</p>	O.D. Tolerance	0.0 -0.05	Insert H Class	 <p>0.5 RE 1.0</p>	  						
	O.D. Tolerance	0.0 -0.05	Insert H Class										
MXF Type	A171												
ROUGHING COPY MILLING	SWING BALL	<table border="1"> <tr> <th>Tool dia.</th> <th>O.D. Tolerance</th> </tr> <tr> <td>φ16</td> <td>0 -0.1</td> </tr> <tr> <td>φ20, φ25</td> <td>-0.01 -0.11</td> </tr> <tr> <td>φ30</td> <td>-0.05 -0.15</td> </tr> </table>  <p>φ16~φ30</p>	Tool dia.	O.D. Tolerance	φ16	0 -0.1	φ20, φ25	-0.01 -0.11	φ30	-0.05 -0.15	 <p>R8~R15</p>	  	<p>WEB CATALOGUE</p> 
	Tool dia.	O.D. Tolerance											
φ16	0 -0.1												
φ20, φ25	-0.01 -0.11												
φ30	-0.05 -0.15												
MSWX Type	Available only on WEB CATALOGUE												
ROUGHING COPY MILLING	SWING BALL	<table border="1"> <tr> <td>O.D. Tolerance</td> <td>-0.05 -0.15</td> <td>Insert G Class</td> </tr> </table>  <p>φ32</p>	O.D. Tolerance	-0.05 -0.15	Insert G Class	 <p>R16</p>	   	<p>WEB CATALOGUE</p> 					
	O.D. Tolerance	-0.05 -0.15	Insert G Class										
MSW Type	Available only on WEB CATALOGUE												
COPY MILLING	SUPER DIEMASTER	<table border="1"> <tr> <td>O.D. Tolerance</td> <td>0 -0.1</td> <td>Insert G, M Class</td> </tr> </table>  <p>φ15~φ42</p>	O.D. Tolerance	0 -0.1	Insert G, M Class	 <p>RE3.5~RE6.0</p>	    						
	O.D. Tolerance	0 -0.1	Insert G, M Class										
SDH Type	A179												

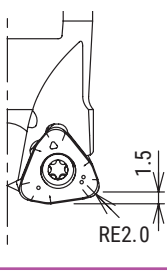
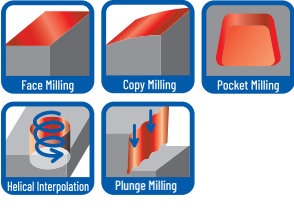

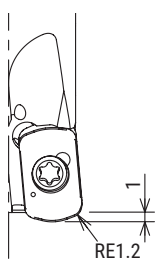
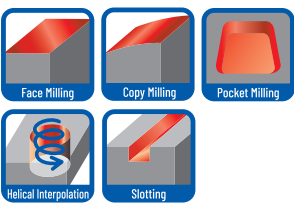

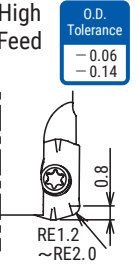
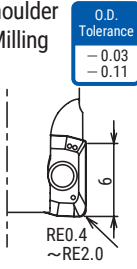
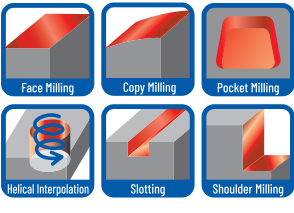

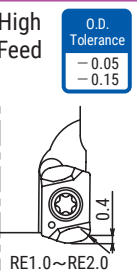
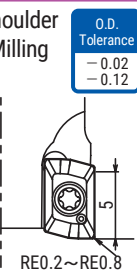
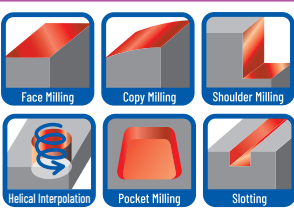



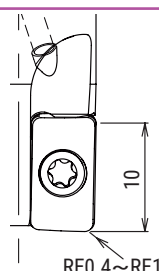
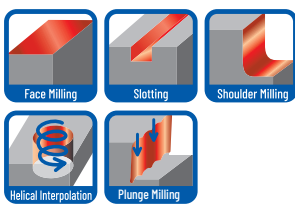

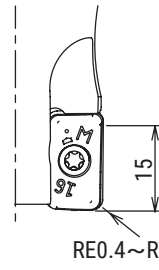
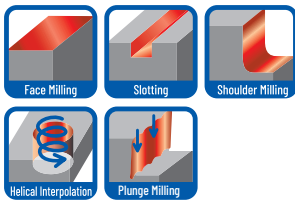
Type	Item Code	Shape / Tool dia.	Cutting edge angle / Max.DOC	Applications	
COPY MILLING	EXTREME DIEMASTER	 O.D. Tolerance: 0 / -0.1 Insert: M Class φ32~φ40	 RE6.0	   	WEB CATALOGUE 
	MTX Type	Available only on WEB CATALOGUE			
FOR ALUMINIUM ALLOY	AERO CHIPPER	 O.D. Tolerance: 0 / -0.1 Insert: E Class φ16~φ42	 RE0.4~RE2.0	    	
	MAM Type	A191			
FOR ALUMINIUM ALLOY	AERO CHIPPER	 O.D. Tolerance: -0.04 / -0.1 Insert: G Class φ20~φ40	 RE0.2~RE4.0	     	
	MAL Type	A193			
FINISHING SIDE & BOTTOM FACE	BACK DRAFT CUTTER	 O.D. Tolerance: 0 / -0.1 Insert: H Class φ20~φ40	Bottom Finishing:  Side Finishing: 	    	WEB CATALOGUE 
	MDB Type	Available only on WEB CATALOGUE			
MULTI-EDGES	S-HEAD	 φ16~φ32	 φDc $^{0}_{-0.02}$	  	
	SMSA Type	A203			
FOR ALUMINIUM ALLOY	S-HEAD	 φ18~φ32	 φDc $^{0}_{-0.02}$	    	
	SMAL Type	A208			

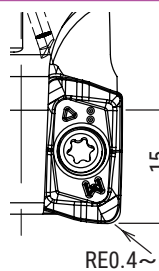
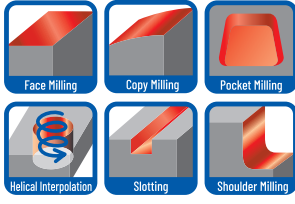

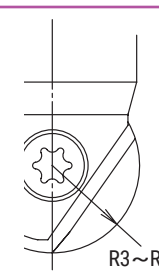

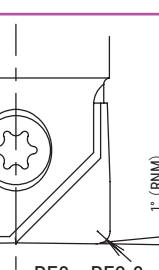
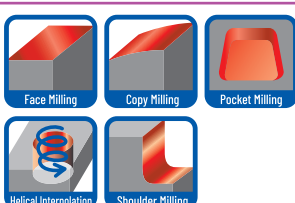

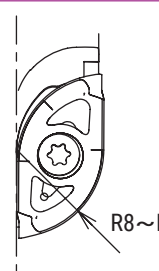



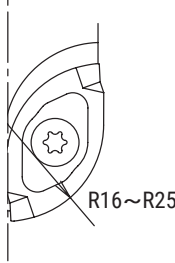





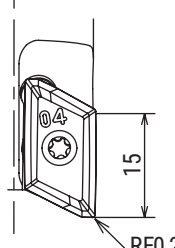







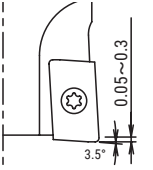
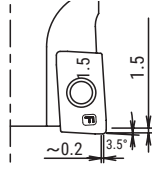







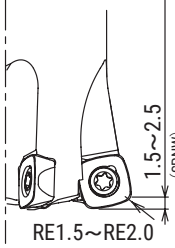







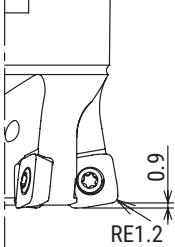



MILLING TOOLS QUICK GUIDE

Type	Item Code	Shape / Tool dia.	Cutting edge angle / Max.DOC	Applications
FOR HEAT RESISTANT ALLOY	S-HEAD	 φ16~φ32	 16~32 r0.5~r3.0 φDc -0.02	 Shoulder Milling  Pocket Milling  Copy Milling  Helical Interpolation
	SMSR Type			
	A210			
FOR HARDENED MATERIALS	S-HEAD	 φ16~φ20	 R8~R10	 Copy Milling  Pocket Milling
	SMHB Type			
FOR HIGH EFFICIENCY MACHINING	CARBIDE SHANK			
	MSN Type	MSN Type φ10~φ32		
	A214	MSN-S Type φ9.8~φ32		

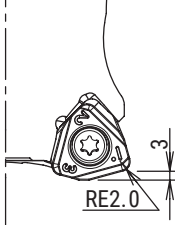









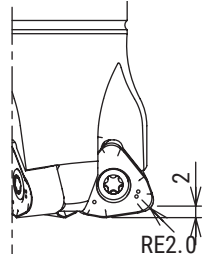

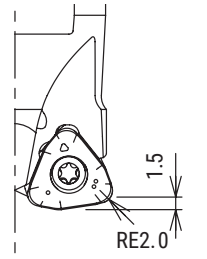
Type	Item Code	Shape / Tool dia.	Cutting edge angle / Max.DOC	Applications	
HIGH FEED COPY MILLING	SKS-GII-09	 <p>O.D. Tolerance: 0 / -0.1 Insert E Class</p>	 <p>0.9 RE1.2</p>		
	SKG-09 Type				
	A063				
HIGH FEED COPY MILLING	SKS EXTREME	 <p>O.D. Tolerance: -0.05 / -0.15 Insert M Class</p>	 <p>2 RE2.0</p>		
	EXSKS-07 Type				
	A073				
HIGH FEED COPY MILLING	SKS EXTREME	 <p>O.D. Tolerance: -0.05 / -0.15 Insert M Class</p>	 <p>1.5 RE2.0</p>		
	EXSKS-05 Type				
	A071				
HIGH FEED COPY MILLING	QM MAX GII	 <p>O.D. Tolerance: -0.05 / -0.15 Insert M Class</p>	 <p>1 RE1.2</p>		
	GMX Type				
	A084				
HIGH FEED COPY MILLING	QM MAX	 <p>Insert H, M Class</p>	<p>High Feed</p>  <p>O.D. Tolerance: -0.06 / -0.14 0.8 RE1.2 ~ RE2.0</p>	<p>Shoulder Milling</p>  <p>O.D. Tolerance: -0.03 / -0.11 6 RE0.4 ~ RE2.0</p>	
	QXP Type				
	A094				
HIGH FEED COPY MILLING	QM MILL	 <p>Insert H, M Class</p>	<p>High Feed</p>  <p>O.D. Tolerance: -0.05 / -0.15 0.4 RE1.0 ~ RE2.0</p>	<p>Shoulder Milling</p>  <p>O.D. Tolerance: -0.02 / -0.12 5 RE0.2 ~ RE0.8</p>	
	PME Type				
	A108				

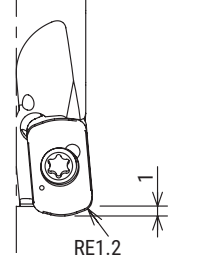

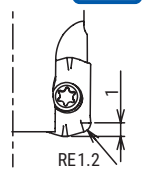
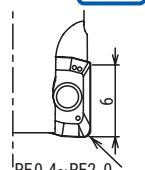

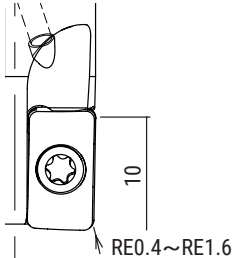
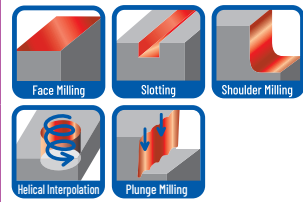

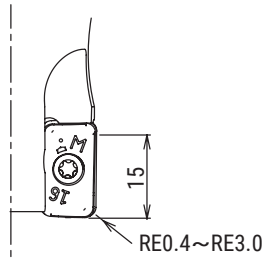



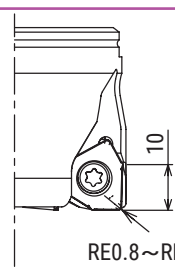





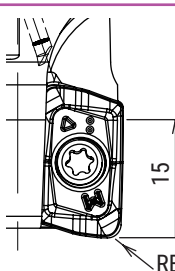







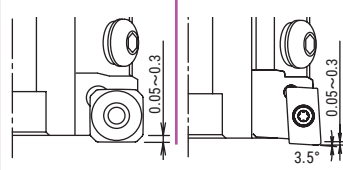



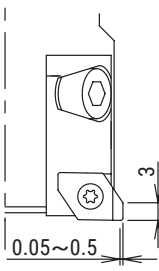

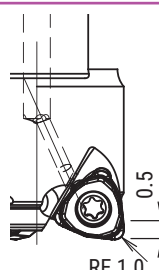

MILLING TOOLS QUICK GUIDE

Type	Item Code	Shape / Tool dia.	Cutting edge angle / Max.DOC	Applications													
SHOULDER MILLING	EXTREME SAP	 <p>O.D. Tolerance: -0.03 / -0.11 Insert: G Class</p>	 <p>10 RE0.4~RE1.6</p>														
	EXSAP-11 Type					A119	φ16~φ32										
SHOULDER MILLING	EXTREME SAP	 <p>O.D. Tolerance: -0.05 / -0.15 Insert: G Class</p>	 <p>15 RE0.4~RE3.0</p>														
	EXSAP-17 Type					A123	φ25~φ32										
SHOULDER MILLING	SIC-EVO	 <p>O.D. Tolerance: -0.05 / -0.15 Insert: E, M Class</p>	 <p>15 RE0.4~RE3.0</p>														
	SSV Type					A139	φ25~φ40										
FINISHING COPY MILLING	MIRROR BALL	 <p>O.D. Tolerance: ±0.008 Insert: F Class</p>	 <p>R3~R16</p>														
	BNM Type					A146	φ6~φ30										
FINISHING COPY MILLING	MIRROR RADIUS	 <p>O.D. Tolerance: -0.002 / -0.018 Insert: F Class</p>	 <p>1° (RNM) / 3° (HRM/FRM) RE0~RE3.0</p>														
	RNM Type					A158	φ6~φ32										
ROUGHING COPY MILLING	SWING BALL	<table border="1" data-bbox="391 1859 518 1960"> <thead> <tr> <th>Tail dia.</th> <th>O.D.</th> </tr> </thead> <tbody> <tr> <td>φ16</td> <td>0</td> </tr> <tr> <td>φ20, φ25</td> <td>-0.1</td> </tr> <tr> <td>φ30</td> <td>-0.11</td> </tr> <tr> <td></td> <td>-0.05</td> </tr> <tr> <td></td> <td>-0.15</td> </tr> </tbody> </table>  <p>Insert: G Class</p>	Tail dia.	O.D.	φ16	0	φ20, φ25	-0.1	φ30	-0.11		-0.05		-0.15	 <p>R8~R15</p>		<p>WEB CATALOGUE</p> 
	Tail dia.		O.D.														
φ16	0																
φ20, φ25	-0.1																
φ30	-0.11																
	-0.05																
	-0.15																
SWBX Type	Available only on WEB CATALOGUE	φ16~φ30															

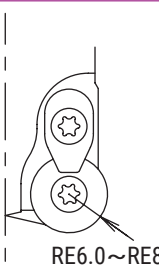









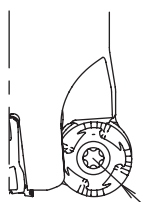





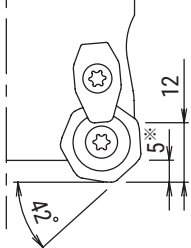







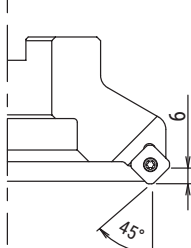



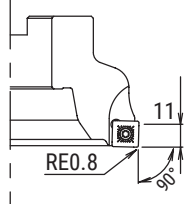



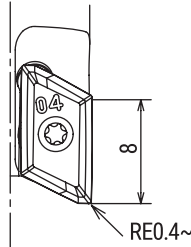

Type	Item Code	Shape / Tool dia.	Cutting edge angle / Max.DOC	Applications		
ROUGHING COPY MILLING	SWING BALL	 <p>O.D. Tolerance: -0.05 to -0.15 Insert: G Class $\phi 32 \sim \phi 50$</p>	 <p>R16~R25</p>	  	<p>WEB CATALOGUE</p> 	
	SWB Type Available only on WEB CATALOGUE					
FOR ALUMINIUM ALLOY	AERO CHIPPER	 <p>O.D. Tolerance: 0 to -0.1 Insert: G Class $\phi 20 \sim \phi 40$</p>	 <p>15 RE0.2~4.0</p>	     		
	ALXM Type A194					
FINISHING SIDE & BOTTOM FACE	BACK DRAFT CUTTER	 <p>O.D. Tolerance: 0 to -0.1 Insert: H Class $\phi 40$</p>	Bottom Finishing  <p>0.05~0.3 3.5°</p>	Side Finishing  <p>1.5 ~0.2 3.5°</p>	    	<p>WEB CATALOGUE</p> 
	DBD Type Available only on WEB CATALOGUE					
HIGH FEED COPY MILLING	SKS-II	 <p>O.D. Tolerance: -0.05 to -0.15 Insert: N, E, M Class $\phi 50 \sim \phi 160$</p>	 <p>1.5~2.5 (SPNW) RE1.5~RE2.0</p>	     		
	SKG Type A050					
HIGH FEED COPY MILLING	SKS-II-09	 <p>O.D. Tolerance: -0.05 to -0.15 Insert: E Class $\phi 40 \sim \phi 80$</p>	 <p>0.9 RE1.2</p>	     		
	SKG-09 Type A062					
HIGH FEED COPY MILLING	SKS EXTREME	 <p>O.D. Tolerance: 0 to -0.2 Insert: M Class $\phi 50 \sim \phi 160$</p>	 <p>3 RE2.0</p>	     		
	EXSKS-09 Type A074					



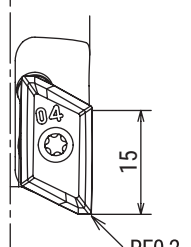







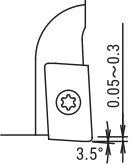
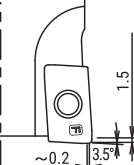



MILLING TOOLS QUICK GUIDE

Type	Item Code	Shape / Tool dia.	Cutting edge angle / Max.DOC	Applications	
HIGH FEED COPY MILLING	SKS EXTREME	 O.D. Tolerance: -0.05 / -0.15 Insert: M Class φ50~φ100	 RE2.0		
	EXSKS-07 Type				
	A072				
HIGH FEED COPY MILLING	SKS EXTREME	 O.D. Tolerance: -0.05 / -0.15 Insert: M Class φ40~φ63	 RE2.0		
	EXSKS-05 Type				
	A070				
HIGH FEED COPY MILLING	QM MAX GII	 O.D. Tolerance: -0.05 / -0.15 Insert: M Class φ50~φ66	 RE1.2		
	GMX Type				
	A083				
HIGH FEED COPY MILLING	QM MAX	 Insert: H, M Class φ40~φ66	High Feed  O.D. Tolerance: -0.05 / -0.15 RE1.2	Shoulder Milling  O.D. Tolerance: -0.02 / -0.12 RE0.4~RE2.0	
	QXP Type				
	A093				
SHOULDER MILLING	EXTREME SAP	 Tool dia. O.D. Tolerance: φ63: -0.03 / -0.11, φ80: -0.02 / -0.12 Insert: G Class φ40~φ80	 RE0.4~RE1.6		
	EXSAP-11 Type				
	A118				
SHOULDER MILLING	EXTREME SAP	 Tool dia. O.D. Tolerance: φ80: -0.05 / -0.15, φ100: -0.2 Insert: G Class φ50~φ125	 RE0.4~RE3.0		
	EXSAP-17 Type				
	A122				

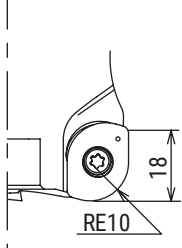

Type	Item Code	Shape / Tool dia.	Cutting edge angle / Max.DOC	Applications										
SHOULDER MILLING	SHOULDER 6	<table border="1"> <tr> <th>Tool dia.</th> <th>O.D. Tolerance</th> <th>Insert</th> </tr> <tr> <td>Ⅲ φ80</td> <td>-0.05 -0.15</td> <td>M Class</td> </tr> <tr> <td>Ⅳ φ100</td> <td>0 -0.2</td> <td></td> </tr> </table> 	Tool dia.	O.D. Tolerance	Insert	Ⅲ φ80	-0.05 -0.15	M Class	Ⅳ φ100	0 -0.2		 <p>10 RE0.8~RE1.6</p>	   	
	Tool dia.	O.D. Tolerance	Insert											
	Ⅲ φ80	-0.05 -0.15	M Class											
Ⅳ φ100	0 -0.2													
EXSIX Type														
A133	φ50~φ160													
SHOULDER MILLING	SIC-EVO	<table border="1"> <tr> <th>Tool dia.</th> <th>O.D. Tolerance</th> <th>Insert</th> </tr> <tr> <td>Ⅲ φ80</td> <td>-0.05 -0.15</td> <td>E, M Class</td> </tr> <tr> <td>Ⅳ φ100</td> <td>-0.025 -0.175</td> <td></td> </tr> </table> 	Tool dia.	O.D. Tolerance	Insert	Ⅲ φ80	-0.05 -0.15	E, M Class	Ⅳ φ100	-0.025 -0.175		 <p>15 RE0.4~RE3.0</p>	     	
	Tool dia.	O.D. Tolerance	Insert											
	Ⅲ φ80	-0.05 -0.15	E, M Class											
Ⅳ φ100	-0.025 -0.175													
SSV Type														
A137	φ40~φ125													
SUPER FINISHING FOR FLAT FACE	FINISH JET MILL	<table border="1"> <tr> <th>O.D. Tolerance</th> <th>Insert</th> </tr> <tr> <td>±0.2</td> <td>H Class</td> </tr> </table> 	O.D. Tolerance	Insert	±0.2	H Class	<p>Super Finishing Corner Finishing</p>  <p>0.05~0.3 0.05~0.3 3.5°</p>		<p>WEB CATALOGUE</p> 					
	O.D. Tolerance	Insert												
	±0.2	H Class												
FJM Type														
Available only on WEB CATALOGUE	φ80~φ250													
FINISHING UP & DOWN MILLING	BACK & FORTH CUTTER	<table border="1"> <tr> <th>O.D. Tolerance</th> <th>Insert</th> </tr> <tr> <td>+0.1 -0.3</td> <td>G Class</td> </tr> </table> 	O.D. Tolerance	Insert	+0.1 -0.3	G Class	 <p>3 0.05~0.5</p>	 	<p>WEB CATALOGUE</p> 					
	O.D. Tolerance	Insert												
	+0.1 -0.3	G Class												
PFC Type														
Available only on WEB CATALOGUE	φ50~φ80													
FINISHING COPY MILLING	DIEMASTER 5G	<table border="1"> <tr> <th>O.D. Tolerance</th> <th>Insert</th> </tr> <tr> <td>0.0 -0.5</td> <td>H Class s</td> </tr> </table> 	O.D. Tolerance	Insert	0.0 -0.5	H Class s	 <p>0.5 RE 1.0</p>	  						
	O.D. Tolerance	Insert												
	0.0 -0.5	H Class s												
XFG Type														
A171	φ52~φ66													
COPY MILLING	SUPER DIEMASTER	<table border="1"> <tr> <th>O.D. Tolerance</th> <th>Insert</th> </tr> <tr> <td>0 -0.2</td> <td>G, M Class</td> </tr> </table> 	O.D. Tolerance	Insert	0 -0.2	G, M Class	 <p>RE6.0~RE8.0</p>	    						
	O.D. Tolerance	Insert												
	0 -0.2	G, M Class												
HDM Type														
A177	φ50~φ80													







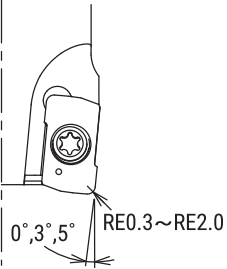



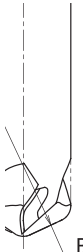



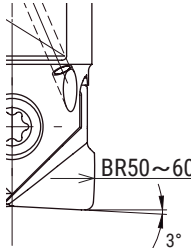





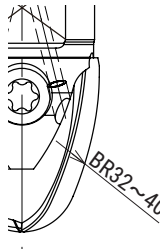



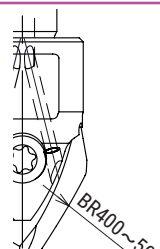



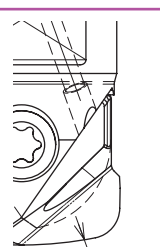

MILLING TOOLS QUICK GUIDE

Type	Item Code	Shape / Tool dia.	Cutting edge angle / Max.DOC	Applications											
COPY MILLING	EXTREME DIEMASTER	<table border="1"> <tr> <td>O.D. Tolerance</td> <td>0 -0.2</td> <td>Insert</td> <td>M Class</td> </tr> </table>  <p>φ50~φ63</p>	O.D. Tolerance	0 -0.2	Insert	M Class	 <p>RE6.0</p>	   	<p>WEB CATALOGUE</p> 						
	O.D. Tolerance	0 -0.2	Insert	M Class											
Available only on WEB CATALOGUE	EXTDM Type														
FOR HEAVY MACHINING	HEPTA MILL	<table border="1"> <tr> <td>O.D. Tolerance</td> <td>-0.025 -0.175</td> <td>Insert</td> <td>H, M Class</td> </tr> </table>  <p>φ50~φ200</p>	O.D. Tolerance	-0.025 -0.175	Insert	H, M Class		     							
	O.D. Tolerance	-0.025 -0.175	Insert	H, M Class											
Available only on WEB CATALOGUE	HEP Type A186														
GENERAL FACE MILLING	DIJET MILL 45	<table border="1"> <tr> <td>Tool dia.</td> <td>O.D. Tolerance</td> <td>Insert</td> <td>G, M Class</td> </tr> <tr> <td>≤ φ63</td> <td>±0.25</td> <td rowspan="2">G, M Class</td> <td rowspan="2"></td> </tr> <tr> <td>≥ φ80</td> <td>±0.5</td> </tr> </table>  <p>φ50~φ125</p>	Tool dia.	O.D. Tolerance	Insert	G, M Class	≤ φ63	±0.25	G, M Class		≥ φ80	±0.5			<p>WEB CATALOGUE</p> 
	Tool dia.	O.D. Tolerance	Insert	G, M Class											
≤ φ63	±0.25	G, M Class													
≥ φ80	±0.5														
Available only on WEB CATALOGUE	SSE45 Type														
GENERAL SHOULDER MILLING	DIJET MILL 90	<table border="1"> <tr> <td>O.D. Tolerance</td> <td>±0.1</td> <td>Insert</td> <td>H, M Class</td> </tr> </table>  <p>φ50~φ125</p>	O.D. Tolerance	±0.1	Insert	H, M Class		 	<p>WEB CATALOGUE</p> 						
	O.D. Tolerance	±0.1	Insert	H, M Class											
Available only on WEB CATALOGUE	SSD90 Type														
FOR ALUMINIUM ALLOY	AERO CHIPPER	<table border="1"> <tr> <td>O.D. Tolerance</td> <td>0 -0.1</td> <td>Insert</td> <td>G Class</td> </tr> </table>  <p>φ40~φ63</p>	O.D. Tolerance	0 -0.1	Insert	G Class		    							
	O.D. Tolerance	0 -0.1	Insert	G Class											
Available only on WEB CATALOGUE	AMX Type A191														
FOR ALUMINIUM ALLOY	AERO CHIPPER	<table border="1"> <tr> <td>O.D. Tolerance</td> <td>0 -0.1</td> <td>Insert</td> <td>G Class</td> </tr> </table>  <p>φ50~φ63</p>	O.D. Tolerance	0 -0.1	Insert	G Class		     							
	O.D. Tolerance	0 -0.1	Insert	G Class											
Available only on WEB CATALOGUE	ALX Type A193														

Type	Item Code	Shape / Tool dia.	Cutting edge angle / Max.DOC	Applications	
FINISHING SIDE & BOTTOM FACE	BACK DRAFT CUTTER	 <p>O.D. Tolerance: 0 / -0.1 Insert: H Class</p> <p>$\phi 50 \sim \phi 80$</p>	<p>Bottom Finishing</p>  <p>Side Finishing</p> 	    	<p>WEB CATALOGUE</p> 
	<p>DBD Type</p> <p>Available only on WEB CATALOGUE</p>				
ROUGHING COPY MILLING	RADIUS MILL	 <p>O.D. Tolerance: -0.05 / -0.15 Insert: M Class</p> <p>$\phi 50 \sim \phi 63$</p>	 <p>RE10</p>	    	<p>WEB CATALOGUE</p> 
	<p>WDR Type</p> <p>Available only on WEB CATALOGUE</p>				

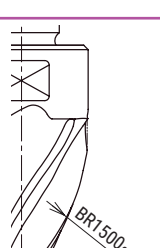
MILLING TOOLS QUICK GUIDE

Type	Item Code	Shape / Tool dia.	Cutting edge angle / Max.DOC	Applications	
5 - AXIS	HIGH PRECISION QM MAX	<div style="display: flex; justify-content: space-between;"> <div>O.D. 0 Tolerance -0.03</div> <div>Insert H, M^{class}</div> </div> 		 	
	MQT Type	$\varphi 16 \sim \varphi 35$			
	A031				

Type	Item Code	Shape / Tool dia.	Barrel R	Applications
5 - AXIS	FUJI BARREL	 φ6~φ12	 BR250	 Face Milling  Copy Milling  Shoulder Milling
	FJVA Type			
	A030			
5 - AXIS	MIRROR BARREL	 O.D. Tolerance: ± 0.002 (Insert Fclass)	 BR50~60 3°	 Face Milling  Copy Milling  Shoulder Milling  Helical Interpolation  Pocket Milling
	KRM Type			
	A025			
5 - AXIS	MIRROR BARREL	 O.D. Tolerance: ± 0.008 (Insert Fclass)	 BR32~40	 Copy Milling  Slotting  Shoulder Milling
	TNM Type			
	A026			
5 - AXIS	MIRROR BARREL	 O.D. Tolerance: ± 0.008 (Insert Fclass)	 BR400~500	 Copy Milling  Slotting  Shoulder Milling  Side Milling
	TPM Type			
	A027			
5 - AXIS	MIRROR BARREL	 O.D. Tolerance: ± 0.008 (Insert Fclass)	 BR32~60	 Face Milling  Copy Milling  Shoulder Milling  Helical Interpolation  Pocket Milling
	LRM Type			
	A028			
5 - AXIS	S-HEAD	 φ16~φ25	 BR1500~2200	 Copy Milling  Slotting  Shoulder Milling  Side Milling
	STLP Type			
	A029			

DESIGNATION SYSTEM FOR MILLING INSERT



1 Shape

Symbol	Shape	Nose angle	Figure
H	Hexagonal	120°	
O	Octagonal	135°	
P	Pentagonal	108°	
S	Square	90°	
T	Triangular	60°	
C	Rhombic	80°	
D		55°	
E		75°	
M		86°	
V		35°	
L	Rectangular	90°	
A	Parallelogram	85°	
R	Round	—	
W	Special design	others	
X			
Y			
Z			

2 Relief angle

Symbol	Relief angle
B	5°
C	7°
D	15°
E	20°
F	25°
G	30°
N	0°
P	11°
O	others

3 Accuracy

Symbol	Corner height	Tolerance (mm)	
		Thickness	I.C. dia.
C	±0.013	±0.025	±0.025
E	±0.025	±0.025	±0.025
G	±0.025	±0.13	±0.025
H	±0.013	±0.025	±0.013
K	±0.013	±0.025	±0.05~±0.13
L	±0.025	±0.025	±0.05~±0.13
M	±0.08~±0.18	±0.13	±0.05~±0.13
N	±0.08~±0.18	±0.025	±0.05~±0.13
U	±0.13~±0.38	±0.13	±0.08~±0.25

Inscribed circle	Tolerance on I.C. dia.	Tolerance on corner height
	K, L, M (class)	M (class)
6.35	±0.05	±0.08
9.525		
12.7	±0.08	±0.13
15.875	±0.1	±0.15
19.05		

4 Groove

Symbol	Shape	Symbol	Shape
N		U	
R		B	
F		H	
W		C	
T		J	
Q		X	others

04 15 ZP E R - S M

6
7
7 8
9
10
11
12

Insert thickness Corner configuration Corner configuration/ Corner angle Cutting edge condition Feed direction Classification I Classification II

5 Cutting edge length

Symbol	length (ℓ)	Symbol	length (ℓ)
H		CM DV E	
O		L	
S		A	
T		R	

6 Thickness

Symbol	Thickness (mm)
02	2.38
T2	2.78
03	3.18
T3	3.97
04	4.76
05	5.56
06	6.35
07	7.94
09	9.52

7 Corner configuration

Symbol	Corner radius (mm)
02	0.2
04	0.4
08	0.8
12	1.2
15	1.5
16	1.6
20	2.0
25	2.5
30	3.0
32	3.2
40	4.0

8 Corner angle

Symbol	Clearance
D	15°
E	20°
F	25°
G	30°
P	11°



9 Symbols of major cutting edge

Symbol	Condition of cutting edge	Shape
F	Sharp edge	
E	Round honing	
T	Angle honing	
S	Combination Honing	

Symbol	Corner angle
A	45°
E	75°
P	90°
Z	others
MO	Round

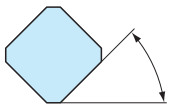

10 Feed direction

Symbol	Hand
R	Right
L	Left
N	Neutral

11 Classification I

Symbol	Work
P	Steel
M	Stainless Steel
K	Cast iron
N	Non ferrous material
S	Heat resistant alloy
H	Hardened material

12 Classification II

Symbol	Application
L	Light cutting
M	Medium cutting
H	Heavy cutting

HIGH FEED TOOLS LINE-UP

HIGH STRENGTH INSERT WITH SHARPNESS & STABILITY.
RELIABLE EVEN AT HIGH FEED RATE & HIGH DEPTH OF CUT.
DEVELOPED FOR HIGH METAL REMOVAL MACHINING.

$ap \leq 3mm$

Rigidity

SKS SERIES

SKS SERIES

**SKS EXTREME
EXSKS 09 Type**



- 6 cutting edges
- High metal removal
- Max. $ap = 3mm$
- Machine type: BT50
- Program R : R3.5

**SKS EXTREME
EXSKS 07 Type**



- 6 cutting edges
- Excellent balance of stability & sharpness
- Max. $ap = 2mm$
- Machine type: BT50
- Program R : R3.0

**SKS GII
SKG/MSG Type**



- 4 cutting edges
- For High feed & High D.O.C. machining
- Max. $ap = 1.5-2.5mm$
- Machine type: BT40-50
- Program R : R2.0-R4.0

**SKS EXTREME
EXSKS 05 Type**



- 6 cutting edges
- For High feed machining with multi-flutes
- Max. $ap = 1.5mm$
- Machine type: BT40-50
- Program R : R2.5

ADVANCED 3-D SHAPED CUTTING EDGE INSERT WITH LOW CUTTING FORCE GEOMETRY . MULTI-FLUTES SPEC. HOLDER . DEVELOPED FOR HIGH SPEED MACHINING EVEN ON SMALL SIZED MACHINE.

$ap \leq 1mm$

QM SERIES

Low cutting force

QM SERIES

**QM MAX GII
GMX/MXG Type**



- 4 cutting edges
- Machining wide variety of materials
- Max.ap = 1.0mm
- Machine type: BT40-50
- Program R : R1.5

**QM MAX
QXP/MXQ Type**



- 2 cutting edges
- Multiple insert choices for wide range of applications
- Max.ap = 1.0mm
- Machine type: BT40-50
- Program R : R1.5

**QM MILL
MPM/PME Type**



- 2 cutting edges
- For roughing to finishing
- low cutting force
- Max.ap = 0.4mm
- Machine type: BT30-40
- Program R : R1.0

● Range of Tool Dia.

Product	No. of corners	Insert spec.	MAX. ap (mm)	Tool Dia. (mm)																	
				10	16	20	25	32	40	50	52	63	66	80	100	125	160				
QM MILL	2	Single sided	0.4	←			→														
QM MAX	2	Single sided	1		←										→						
QM MAX GII	4	Double sided	1		←										→						
EXSKS-05	6	Double sided	1.5		←						→										
SKSGII	4	Single sided	1.5 - 2.5		←										→						
EXSKS-07	6	Double sided	2		←						→										
EXSKS-09	6	Double sided	3			←										→					

SHOULDER MILLING TOOLS LINE-UP

■ Shoulder Milling Series

SIC-EVO (ZOMT16)
QM MAX (ZPMT10)
QM MILL (ZOMT06)



- Single-sided 2 cutting edge insert
- Excellent chips control design
- Reliable even for long overhang machining

SHOULDER EXTREME
EXSAP-11 type
EXSAP-17 type



- Double-sided 4 cutting edge insert
- G class ground insert gives good surface finish on bottom & side wall

SHOULDER 6
EXSIX type



- Double-sided 6 cutting edge insert
- High cutting edge strength
- For heavy roughing process

Range of Tool Dia.

Product	No. of corners	Insert spec.	MAX. ap (mm)	Tool Dia. (mm)														
				10	16	20	25	32	40	50	52	63	66	80	100	125	160	
QM MILL	2	Single sided	5	← $\phi 10 \sim \phi 32$ →														
QM MAX	2	Single sided	9		← $\phi 16 \sim \phi 66$ →													
SIC-EVO	2	Single sided	15			← $\phi 25 \sim \phi 125$ →												
EXSAP-11	4	Double sided	10		← $\phi 16 \sim \phi 80$ →													
EXSAP-17	4	Double sided	15			← $\phi 25 \sim \phi 125$ →												
EXSIX	6	Double sided	10						← $\phi 50 \sim \phi 160$ →									

Selection Guide

Product	Cutting Force	Chip Control	Surface Finish	Wall Accuracy	Cutting Edge Strength	No. of Cutting Edges
SIC-EVO (ZOMT16) QM MAX (ZPMT10) QM MILL (ZOMT06)	★★★	★★★	★★	★★	★	★
EXSAP11 EXSAP17	★★	★★	★★★★	★★★★	★★	★★
EXSIX	★★	★★	★	★★	★★★★	★★★★

Modular Head Series

■ PROPER MOUNTING OF MODULAR HEADS

1 Cleaning



Remove dirt and chips with air from the connecting thread and face of modular head and MSN/MGN shank holder.

2 Initial Tightening



Tighten by hand until the head and the shank holder faces touch.

3 Final Tightening



Tighten slowly with torque control spanner wrench or DIJET DS type spanner wrench and confirm that there is no gap.

- Attention)
1. Final tightening without initial tightening cause connecting thread damage.
 2. Only use DS type spanner wrench when use Solid modular head (SMSA/SMSR/SMAL type)

Attention

1. Only use torque control spanner wrench or DIJET DS type spanner wrench.
In case of choosing torque control spanner wrench, confirm that the wrench size is matched to the dimensions W & C of each modular head.



Torque control spanner

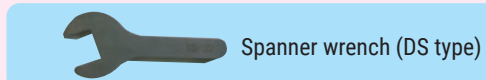

Spanner wrench (DS type)

2. Only apply gentle pressure on wrench.
3. Confirm there is no gap between MSN/MGN shank holder and modular head

■ Steel modular heads

Thread	Tightening torque	Spanner size(W)
M6	8.0N·m	8 [☆] 10
M8	16N·m	12 [☆]
M10	16N·m	14, 15
M12	20N·m	17, 19
M16	25N·m	22, 26

■ Solid modular heads(SMSA/SMSR/SMAL)

Thread	Tightening torque	Spanner size(W)	Cat.No. 
M8	10~11N·m	14	DS-14
M10	10~11N·m	14	DS-14
M10	10~16N·m	17	DS-17
M12	15~20N·m	19, 22	DS-19, DS-22
M16	20~25N·m	27	DS-27

Note) Modular heads are supplied without spanner wrench

Modular Head Series

SELECTION OF MSN CARBIDE SHANK HOLDER

When using modular head over $\varnothing 16\text{mm}$, please select MSN carbide shank which the diameter ($\varnothing D1$) is 1 mm or smaller than modular head ($\varnothing Dc$).

Wrong selection can cause damage to the carbide shank.

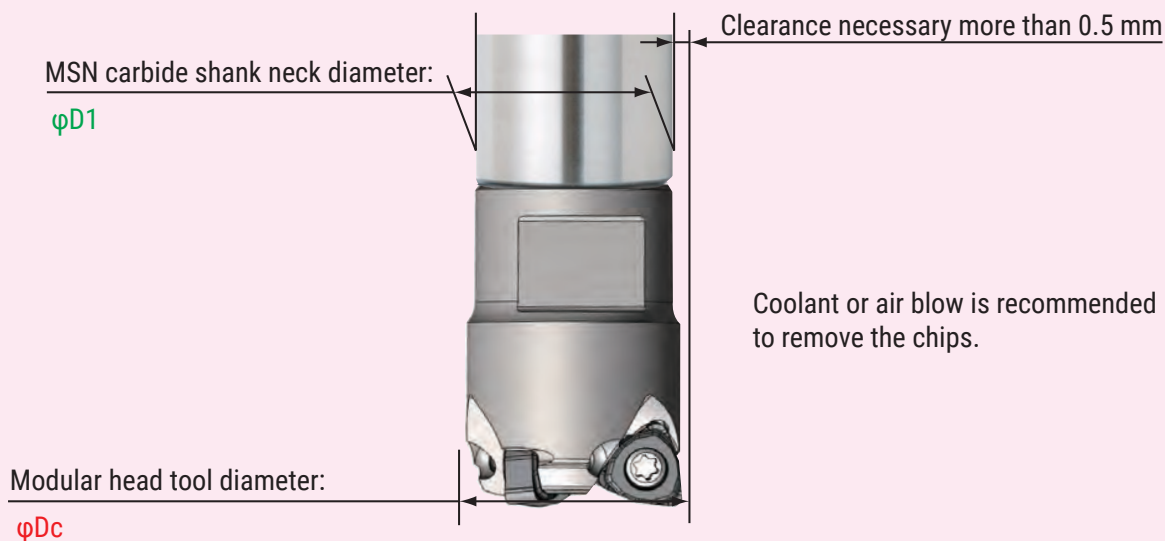

Caution for mounting in shrink fit holder.

When you use a carbide shank and a modular head on a shrink fit holder, please shrink fit only the carbide shank without mounting the modular head. Mount the modular head on the shank after shrink fit operation is complete. In case of shrink fit MSN shank + modular head together, it will be difficult to loosen due to heat

5-AXIS Series

TECHNOLOGY

Designs that allow you to machine freely & quickly

Advanced machining technology that enables high-precision and high efficiency

A line-up that supports machining of complex shapes found in the Die&Mould and Aerospace industries.

5-AXIS Series



KRM
TYPE

Insert for "MIRROR BARREL"

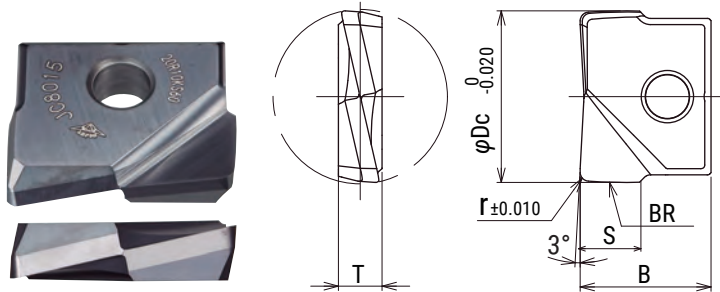

Radius form accuracy on the outer periphery $\pm 0.010\text{mm}$

Corner radius accuracy of inserts within $\pm 0.010\text{mm}$

Cat.No.	Grade		Dimensions (mm)					
	JC8015	DH102	ϕDc	r	BR	S	B	T
KRM-160-R10-BR50	●	●	16	1	50	5.7	12	4
KRM-200-R10-BR60	●	●	20	1	60	6.8	15	5
KRM-250-R10-BR60	●	●	25	1	60	7.3	18.5	6
KRM-300-R10-BR60	●	●	30	1	60	9.1	22.5	7

Through coolant hole



MRX
TYPE

Modular Type

Accuracy of MRX after combined O.D. run out: below 15 μm (Target below 10 μm).
When using KRM type insert/Corner radius accuracy: within $\pm 0.010\text{mm}$. Radius form accuracy on the outer periphery: within $\pm 0.010\text{mm}$.

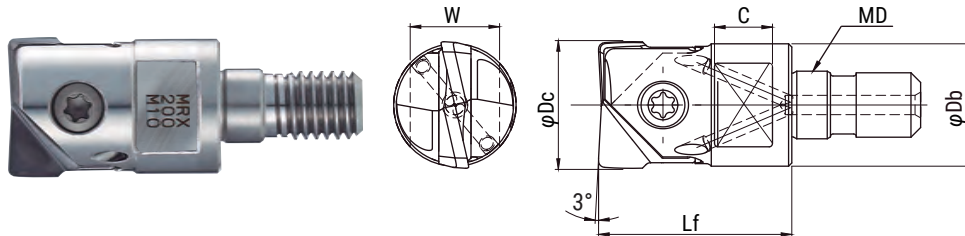

Cat.No.	Stock	Dimensions (mm)						Insert		Parts	
		ϕDc	Lf	ϕDb	MD	C	W				
MRX-160-M8	●	16	23	15	M8	8	12	RNM-160/170... FRM-160/170...	/HRM-160/170... /KRM-160...	FSW-4013H	A-15
MRX-200-M10	●	20	30	19	M10	8	14	RNM-200/210... FRM-200/210...	/HRM-200/220... /KRM-200...	FSW-5016H	A-20W
MRX-250-M12	●	25	35	24	M12	10	17	RNM-250/260...	/FRM-250... /KRM-250...	FSW-6020	A-30
MRX-300-M16	●	30	43	29	M16	12.5	22	RNM-300...	/FRM-200/220... /KRM-300...	FSW-8025S	A-30

Clamp screw	Torque(N·m)
FSW-4013H	3.0
FSW-5016H	4.0
FSW-6020	5.0
FSW-8025S	6.0

5-AXIS Series

5
axis

TNM
TYPE

Insert for "MIRROR BARREL"

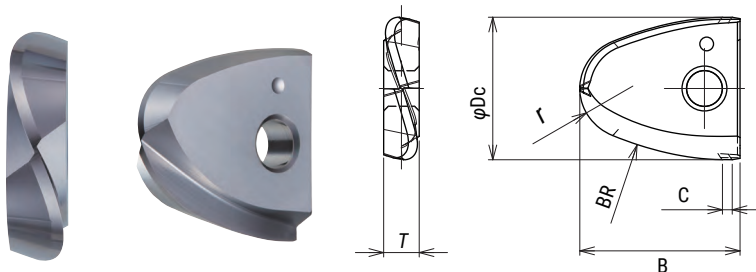

Corner radius accuracy
of inserts within
 $\pm 0.010\text{mm}$

Cat.No.	Grade		Dimensions (mm)					
	JC8015	FZ15	ϕDc	r	BR	B	T	C
TNM-160-NR6BR32	●	●	16	6	32	18	4	1
TNM-200-NR8BR40	●	●	20	8	40	21	5	1

Through
coolant
hole

5
axis

MTP
TYPE

MIRROR BARREL Modular Type

Accuracy of MTP after combined O.D. run out: below 15 μm (Target below 10 μm).
When using TNM type insert / Radius form accuracy on the outer periphery: within $\pm 0.010\text{mm}$.

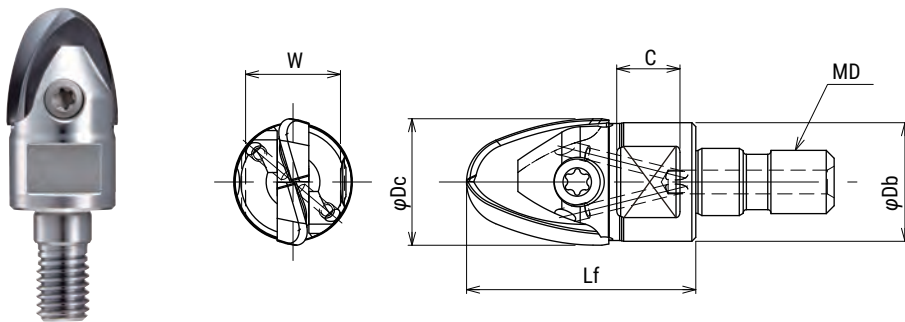

Clamp screw	Torque(N·m)
FSW-4013H	3.0
FSW-5016H	4.0

Cat.No.	Stock	Dimensions (mm)						Insert	Parts	
		ϕDc	Lf	ϕDb	MD	C	W		Screw	Wrench
MTP-160-M8	●	16	29	15	M8	8	12	TPM-160... TNM-160...	FSW-4013H	A-15
MTP-200-M10	●	20	36	19	M10	9	14	TPM-200... TNM-200...	FSW-5016H	A-20W

5-AXIS Series

5 axis

TPM
TYPE

Insert for "MIRROR BARREL"

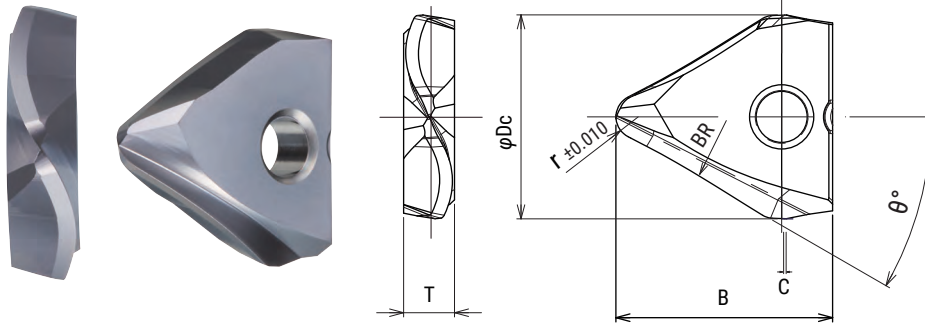

Radius form accuracy on the outer periphery ±0.010mm

Radius accuracy of inserts within ±0.010mm

Cat.No.	Grade		Dimensions (mm)						
	JC8015	DH102	φDc	r	BR	B	T	C	θ°
TPM-160-NR2T30BR400	●	●	16	2	400	17	4	1	30°
TPM-200-NR2T30BR500	●	●	20	2	500	20	5	1	30°

Through coolant hole

5 axis

MTP
TYPE

MIRROR BARREL Modular Type

Accuracy of MTP after combined O.D. run out: below 15 μm (Target below 10 μm).
When using TPM type insert / Corner Radius accuracy: within $\pm 0.010\text{mm}$. Radius form accuracy on the outer periphery: within $\pm 0.010\text{mm}$.

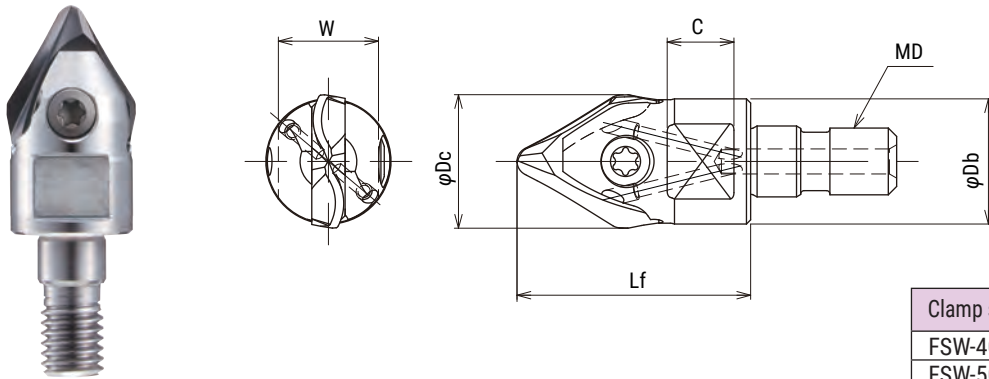

Clamp screw	Torque(N·m)
FSW-4013H	3.0
FSW-5016H	4.0

Cat.No.	Stock	Dimensions (mm)						Inserts	Parts	
		φDc	Lf	φDb	MD	C	W		Screw	Wrench
MTP-160-M8	●	16	28	15	M8	8	12	TPM-160... TNM-160...	FSW-4013H	A-15
MTP-200-M10	●	20	35	19	M10	9	14	TPM-200... TNM-200...	FSW-5016H	A-20W

5-AXIS Series

5
axis

LRM
TYPE

Insert for "MIRROR BARREL"

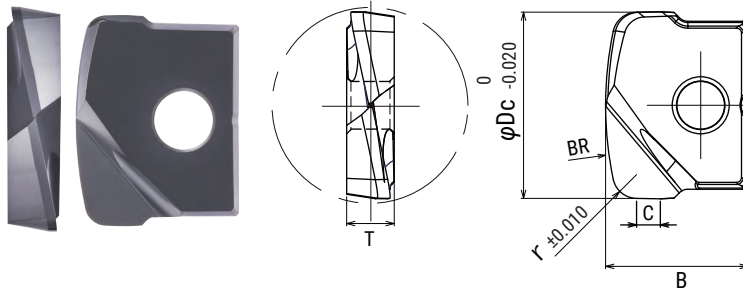

Radius form accuracy
on the bottom
 $\pm 0.010\text{mm}$

Corner radius accuracy
of inserts within
 $\pm 0.010\text{mm}$

Cat.No.	Grade		Dimensions (mm)					
	JC8015	DH102	ϕDc	r	BR	B	T	C
LRM-160-R20-BR32	●	●	16	2	32	12	4	2
LRM-200-R30-BR40	●	●	20	3	40	15	5	2
LRM-250-R30-BR50	●	●	25	3	50	18.5	6	2.5
LRM-300-R30-BR60	●	●	30	3	60	22.5	7	3

Through
coolant
hole

5
axis

MBX
TYPE

Modular Type

Accuracy of MBX after combined O.D. run out: below 15 μm (Target below 10 μm).
When using LRM type insert/Corner radius accuracy: within $\pm 0.010\text{mm}$. Radius form accuracy on the front edge: within $\pm 0.010\text{mm}$.

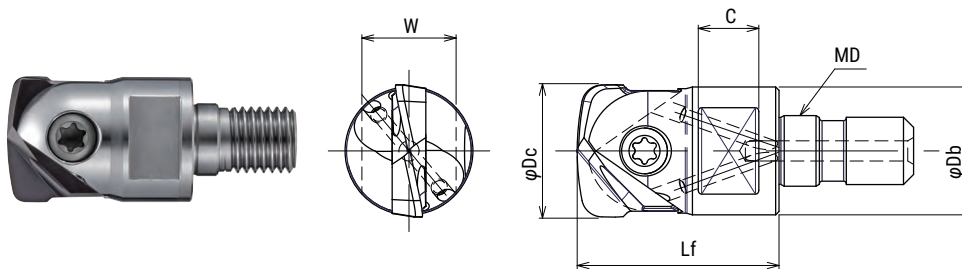

Clamp screw	Torque(N.m)
FSW-4013H	3.0
FSW-5016H	4.0
FSW-6020	5.0
FSW-8025S	6.0

Cat.No.	Stock	Dimensions (mm)						Insert		Parts	
		ϕDc	Lf	ϕDb	MD	C	W			Screw	Wrench
MBX-160-M8	●	16	23	15	M8	8	12	BNM-160...	LRM-160...	FSW-4013H	A-15
MBX-200-M10	●	20	30	19	M10	8	14	BNM-200...	LRM-200...	FSW-5016H	A-20W
MBX-250-M12	●	25	35	24	M12	10	17	BNM-250...	LRM-250...	FSW-6020	A-30
MBX-300-M16	●	30	43	29	M16	12.5	22	BNM-300...	LRM-300...	FSW-8025S	A-30

5-AXIS Series



STLP
TYPE

Solid Modular Type

● 4flutes Helix angle 30°

Radius form accuracy
on the outer periphery
±0.010mm

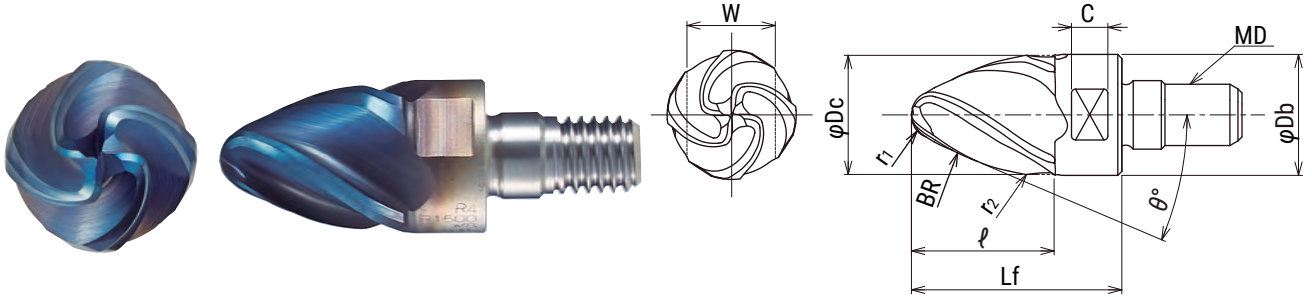

Cat.No.	Stock	Grade	No. of Flutes	Dimensions (mm)										
				ϕDc	ℓ	Lf	BR	r_1	r_2	θ°	ϕDb	MD	C	W
STLP-4160T20R4-M8	●	DH115	4	16	17.7	26	1500	4	4	20°	15	M8	5.5	14
STLP-4200T15R4-M10	●			20	30	38	1500	4	5	15°	19	M10	5.5	17
STLP-4200T20R5-M10	●			20	22	30	1500	5	5	20°	19	M10	5.5	17
STLP-4250T20R5-M12	●			25	28	38	2,200	5	5	20°	24	M12	5.5	22

ϕDc (mm)	Torque	Width across flats W (mm)	DIJET DS type spanner
$\phi 16$	10~11 N·m	14	DS-14
$\phi 20$	10~16 N·m	17	DS-17
$\phi 25$	15~20 N·m	22	DS-22

5-AXIS Series

FJVA
TYPE

"FUJI BARRELL"

- 4flutes
- For shrink fit holder

Radius form accuracy
on the outer periphery
 $\pm 0.010\text{mm}$

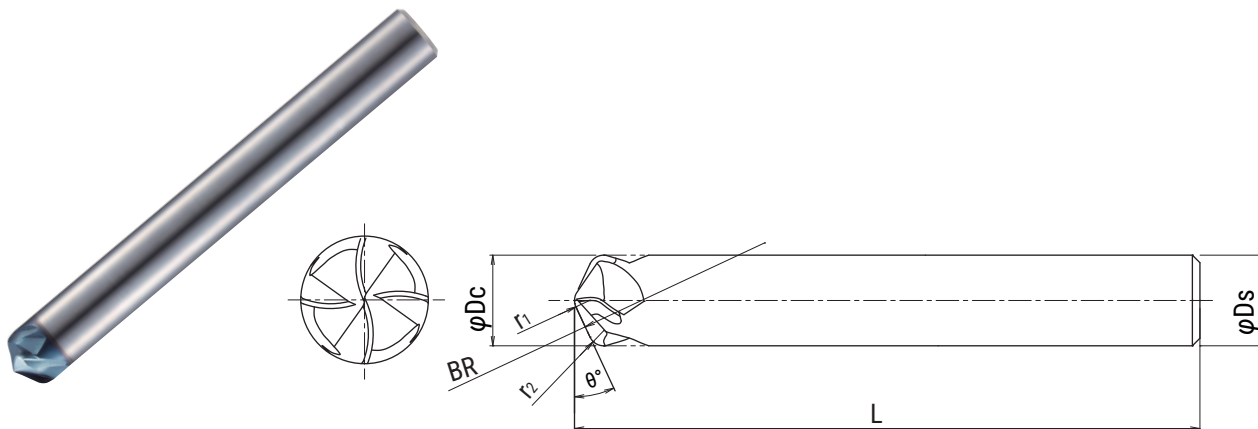

Cat.No.	Stock	Grade	No.of Flutes	Dimensions (mm)						
				ϕDc	BR	r_1	r_2	θ°	L	ϕDs
FJVA4060S06-R250	●	DH115	4	6	250	1	1	25°	60	6
FJVA4080S08-R250	●			8	250	1	1.2	25°	75	8
FJVA4100S10-R250	●			10	250	1	1.75	25°	80	10
FJVA4120S12-R250	●			12	250	1	1.75	25°	100	12

5-AXIS Series



MQT
TYPE

High precision "QM MAX"

- 3 different angled bodies (0°, 3°, and 5°) that cover a range of tapered walls from 0° ~ 8°
- Possible to use even on 3 axis machine with 3° or 5° angled body ; A03 type or A05 type
- High tolerance insert-pocket for the ground inserts
- High efficiency with multi flutes



Fig 1

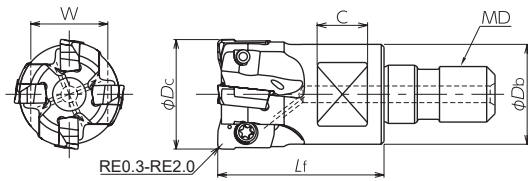
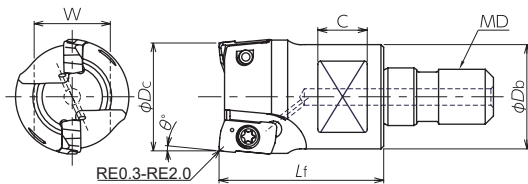

Fig 2



Inclination angle θ°	Cat.No.	Stock	No. of inserts	Dimensions (mm)						Parts		Insert	Fig.				
				φDc	Lf	φDb	MD	C	W	Screws	Wrench						
0°	MQT-2016A00-M8	●	2	16	23	14	M8	8	12	TSW-2556H	A-08	XP**100308ZER-R YPHW1003**Z*R-** ZPMT1003**ZER-PL	1				
	MQT-4020A00-M10	●	4	20	30	18	M10	9	14								
	MQT-5025A00-M12	●	5	25	35	22.5	M12	10	17	DSW-2563H							
	MQT-6032A00-M16	●	6	32	43	29	M16	12	22								
MQT-6035A00-M16	●	35															
3°	MQT-2016A03-M8	●	2	16	23	14	M8	8	12	TSW-2556H			A-08	XP**100308ZER-R YPHW1003**Z*R-** ZPMT1003**ZER-PL	2		
	MQT-2020A03-M10	●		20	30	18	M10	9	14								
5°	MQT-2016A05-M8	●		2	16	23	14	M8	8		12	TSW-2556H			A-08	XP**100308ZER-R YPHW1003**Z*R-** ZPMT1003**ZER-PL	2
	MQT-2020A05-M10	●			20	30	18	M10	9		14						

Clamp screw	Torque(N.m)
TSW-2556H	1.1
DSW-2563H	

5-AXIS Series

Insert

For tapered wall finishing
 (XPHW100308ZER-R)
 (XPHT100308RZER-R)

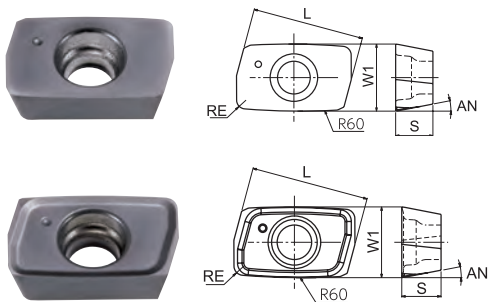

For finishing side face
 (YPHW1003**ZER-15)
 (YPHW100308ZER-F)
 (YPHW100308ZTR-F1)

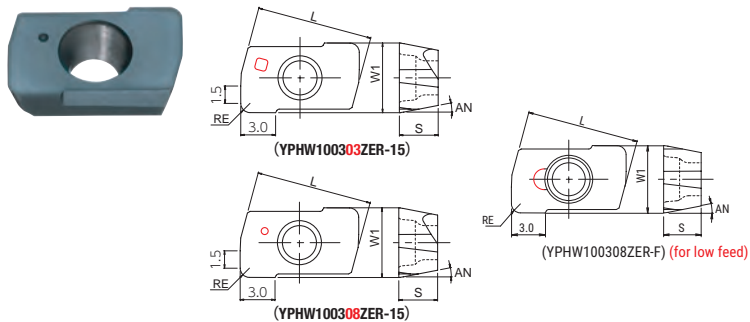

Shoulder milling insert
 (for semi-finishing to finishing)
 ZPMT1003**ZER-PL*

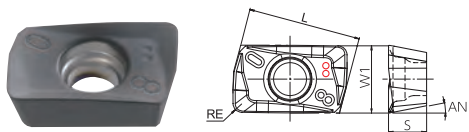

CBN Insert

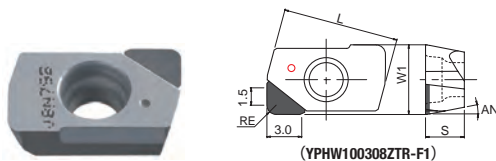

Type	Cat.No.	Tolerance	PVD Coating				Cermet	CBN	Dimensions (mm)				
			DH102	JC8015	JC8050	JC8118			RE	L	W1	S	AN
For Tapered wall finishing	XPHW100308ZER-R	H	●	●			●		0.8	10.06	6	3.35	11°
	XPHT100308ZER-R			●			●						
For Finishing side face	YPHW100303ZER-15	H	●	●					0.3	10.06	6	3.35	11°
	YPHW100308ZER-15		●				●						
	YPHW100308ZER-F			●			●		0.8				
	YPHW100308ZTR-F1						●						
Shoulder milling insert (for semi-finishing to finishing)	ZPMT100304ZER-PL	M	●		●	●			0.4	10.08	3.4	11°	
	ZPMT100308ZER-PL		●		●	●							0.8
	ZPMT100320ZER-PL		●		●	●			2				

5-AXIS Series

Recommended cutting conditions

● KRM Type Side finishing



Material	Grade	Tool dia.(mm)							
		16				20			
		a_p (mm)	a_e (mm)	n (min ⁻¹)	V_f (mm/min)	a_p (mm)	a_e (mm)	n (min ⁻¹)	V_f (mm/min)
Carbon steel (S50C, S55C) below 250HB	JC8015	0.8	0.15	5,970	2,390	1	0.15	4,770	1,910
Cast steel (GM190, ICD5) below 285HB	JC8015	0.8	0.15	5,970	2,390	1	0.15	4,770	1,910
Tool & die steel (SKD61, SKD11) below 255HB	JC8015	0.8	0.15	5,970	2,390	1	0.15	4,770	1,910
Mold steel (HPM7, PX5, P20) 30-36 HRC	JC8015	0.8	0.12	5,970	2,390	1	0.12	4,770	1,910
Mold steel (NAK80, HPM1, P21) 38-43HRC	JC8015	0.8	0.12	5,570	1,670	1	0.12	4,460	1,340
Hardened die steel (SKD61, DAC, DHA) 42-52HRC	DH102	0.6	0.1	4,970	750	0.7	0.1	3,980	600
Hardened die steel (SKD11, SL, DC11) 55-62HRC	DH102	0.5	0.1	3,980	600	0.7	0.1	3,180	480
Grey cast iron (FC250) 160-260HB	DH102	0.8	0.2	6,960	3,480	1	0.2	5,570	3,340
Nodular cast iron (FCD700) 170-300HB	DH102	0.8	0.2	6,960	3,480	1	0.2	5,570	3,340
Austenitic stainless steel (SUS304, 316, 317) 17Cr	JC8015	0.8	0.12	5,570	2,230	1	0.12	4,460	1,780
Ferritic & martensitic stainless steel (SUS403, 420J2, 430) 13Cr	JC8015	0.8	0.12	5,570	2,230	1	0.12	4,460	1,780
Titanium alloy (Ti-6Al-4V) 35-43HRC	JC8015	0.5	0.1	1,990	480	0.6	0.1	1,590	380
Heat resistant alloy (INCO718) 35-43HRC	JC8015	0.5	0.1	1,590	380	0.6	0.1	1,270	300

Please refer to chart and formula below to calculate a_p .

H(Cusp Height)

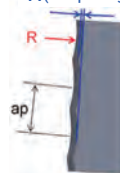

$$a_p = 2 \sqrt{(R^2 - (R - H)^2)}$$

a_p (mm)		Cusp height (mm)									
Cat.No.	R	0.001	0.002	0.003	0.004	0.005	0.006	0.007	0.008	0.009	0.010
KRM-160-R10-BR50	50	0.63	0.89	1.10	1.26	1.41	1.55	1.67	1.79	1.90	2.00
KRM-200-R10-BR60	60	0.69	0.98	1.20	1.39	1.55	1.70	1.83	1.96	2.08	2.19

Note

1. Please adjust cutting conditions according to machine rigidity or work rigidity.
2. These parameters are for overhang length 3Dc. See right table for longer application.
3. In case of chatter occurring, recommended to reduce a_p or rpm and keep feed per tooth.
4. Use air blow.

Overhang (l/D_c)	n (min ⁻¹)	V_f (mm/min)
~ 3Dc	100%	100%
3Dc ~ 5Dc	70%	70%
5Dc ~ 10Dc	50%	50%

5-AXIS Series

■ Recommended cutting conditions



● KRM Type Side finishing

Material	Grade	Tool dia.(mm)							
		25				30			
		a_p (mm)	a_e (mm)	n (min^{-1})	V_f (mm/min)	a_p (mm)	a_e (mm)	n (min^{-1})	V_f (mm/min)
Carbon steel (S50C, S55C) below 250HB	JC8015	1.2	0.15	3,820	1,530	1.2	0.15	3,180	1,270
Cast steel (GM190, ICD5) below 285HB	JC8015	1.2	0.15	3,820	1,530	1.2	0.15	3,180	1,270
Tool & die steel (SKD61, SKD11) below 255HB	JC8015	1.2	0.15	3,820	1,530	1.2	0.15	3,180	1,270
Mold steel (HPM7, PX5, P20) 30-36 HRC	JC8015	1.2	0.12	3,820	1,530	1.2	0.12	3,180	1,270
Mold steel (NAK80, HPM1, P21) 38-43HRC	JC8015	1	0.12	3,570	1,070	1	0.12	2,970	890
Hardened die steel (SKD61, DAC, DHA) 42-52HRC	DH102	0.8	0.1	3,180	480	0.8	0.1	2,650	400
Hardened die steel (SKD11, SL, DC11) 55-62HRC	DH102	0.7	0.1	2,550	380	0.7	0.1	2,120	320
Grey cast iron (FC250) 160-260HB	DH102	1.2	0.2	4,460	2,680	1.2	0.2	3,710	2,230
Nodular cast iron (FCD700) 170-300HB	DH102	1.2	0.2	4,460	2,680	1.2	0.2	3,710	2,230
Austenitic stainless steel (SUS304, 316, 317) 17Cr	JC8015	1.2	0.12	3,570	1,430	1.2	0.12	2,970	1,190
Ferritic & martensitic stainless steel (SUS403, 420J2, 430) 13Cr	JC8015	1.2	0.12	3,570	1,430	1.2	0.12	2,970	1,190
Titanium alloy (Ti-6Al-4V) 35-43HRC	JC8015	0.7	0.1	1,270	320	0.7	0.1	1,060	270
Heat resistant alloy (INCO718) 35-43HRC	JC8015	0.7	0.1	1,020	260	0.7	0.1	850	210

Please refer to chart and formula below to calculate a_p .

$$a_p = 2 \sqrt{(R^2 - (R - H)^2)}$$

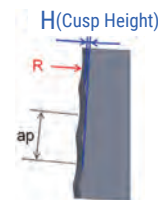

a_p (mm)		Cusp height (mm)									
Cat.No.	R	0.001	0.002	0.003	0.004	0.005	0.006	0.007	0.008	0.009	0.010
KRM-250-R10-BR60	60	0.69	0.98	1.20	1.39	1.55	1.70	1.83	1.96	2.08	2.19
KRM-300-R10-BR60											

Note

1. Please adjust cutting conditions according to machine rigidity or work rigidity.
2. These parameters are for overhang length 3Dc. See right table for longer application.
3. In case of chatter occurring, recommended to reduce a_p or rpm and keep feed per tooth.
4. Use air blow.

Overhang (l/Dc)	n (min^{-1})	V_f (mm/min)
$\sim 3Dc$	100%	100%
$3Dc \sim 5Dc$	70%	70%
$5Dc \sim 10Dc$	50%	50%

5-AXIS Series

■ Recommended cutting conditions



● TNM Type Side finishing with Barrel R

Material	Grade	Tool dia.(mm)							
		16				20			
		a_p (mm)	a_e (mm)	n (min ⁻¹)	V_f (mm/min)	a_p (mm)	a_e (mm)	n (min ⁻¹)	V_f (mm/min)
Carbon steel (S50C, S55C) below 250HB	JC8015	~1	0.2	6,960	2,780	~1	0.2	5,570	2,230
Cast steel (GM190, ICD5) below 285HB	JC8015	~1	0.2	6,960	2,780	~1	0.2	5,570	2,230
Tool & die steel (SKD61, SKD11) below 255HB	JC8015	~1	0.2	6,960	2,780	~1	0.2	5,570	2,230
Mold steel (HPM7, PX5, P20) 30-36 HRC	JC8015	~1	0.2	6,960	2,780	~1	0.2	5,570	2,230
Mold steel (NAK80, HPM1, P21) 38-43HRC	JC8015	~1	0.2	5,970	2,390	~1	0.2	4,770	1,910
Hardened die steel (SKD61, DAC, DHA) 42-52HRC	JC8015	~1	0.1	4,970	1,490	~1	0.1	3,980	1,190
Grey cast iron (FC250) 160-260HB	JC8015	~1	0.2	6,960	2,780	~1	0.2	5,570	2,230
Nodular cast iron (FCD700) 170-300HB	JC8015	~1	0.2	6,960	2,780	~1	0.2	5,570	2,230
Austenitic stainless steel (SUS304, 316, 317) 17Cr	JC8015	~1	0.2	6,960	2,090	~1	0.2	5,570	1,670
Ferritic & martensitic stainless steel (SUS403, 420J2, 430) 13Cr	JC8015	~1	0.2	6,960	2,090	~1	0.2	5,570	1,670
Titanium alloy (Ti-6Al-4V) 35-43HRC	JC8015	~0.4	0.15	4,970	1,490	~0.4	0.15	3,980	1,190
Heat resistant alloy (INCO718) 35-43HRC	JC8015	~0.4	0.1	3,980	800	~0.4	0.1	3,180	640
Aluminium alloy	FZ15	~1.5	0.25	9,950	4,980	~1.5	0.25	7,960	4,780

Please refer to chart and formula below to calculate a_p .

$$a_p = 2 \sqrt{(R^2 - (R - H)^2)}$$

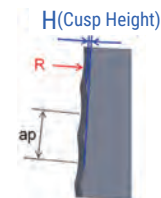

a_p (mm)		Cusp height (mm)									
Cat.No.	R	0.001	0.002	0.003	0.004	0.005	0.006	0.007	0.008	0.009	0.010
TNM-160-NR6BR32	32	0.51	0.72	0.88	1.01	1.13	1.24	1.34	1.43	1.52	1.60
TNM-200-NR8BR40	40	0.57	0.80	0.98	1.13	1.26	1.39	1.50	1.60	1.70	1.79

Note

1. Please adjust cutting conditions according to machine rigidity or work rigidity.
2. These parameters are for overhang length 3Dc. See right table for longer application.
3. In case of chatter occurring, recommended to reduce a_p or rpm and keep feed per tooth.
4. Use air blow.

Overhang (l/Dc)	n (min ⁻¹)	V_f (mm/min)
~ 3Dc	100%	100%
3Dc ~ 5Dc	70%	70%
5Dc ~ 10Dc	50%	50%

5-AXIS Series

Recommended cutting conditions



TNM Type - with Tip R

Material	Grade	Tool dia.(mm)							
		16				20			
		a_p (mm)	a_e (mm)	n (min ⁻¹)	V_f (mm/min)	a_p (mm)	a_e (mm)	n (min ⁻¹)	V_f (mm/min)
Carbon steel (S50C, S55C) below 250HB	JC8015	0.15	0.2	10,940	4,380	0.15	0.25	8,750	5,250
Cast steel (GM190, ICD5) below 285HB	JC8015	0.15	0.2	10,940	4,380	0.15	0.25	8,750	5,250
Tool & die steel (SKD61, SKD11) below 255HB	JC8015	0.15	0.2	10,940	4,380	0.15	0.25	8,750	5,250
Mold steel (HPM7, PX5, P20) 30-36 HRC	JC8015	0.15	0.2	9,950	3,980	0.15	0.25	7,960	4,780
Mold steel (NAK80, HPM1, P21) 38-43HRC	JC8015	0.1	0.2	7,960	2,390	0.1	0.25	6,370	3,190
Hardened die steel (SKD61, DAC, DHA) 42-52HRC	JC8015	0.1	0.2	5,970	1,790	0.1	0.25	4,770	2,390
Grey cast iron (FC250) 160-260HB	JC8015	0.15	0.2	10,940	5,470	0.15	0.25	8,750	6,130
Nodular cast iron (FCD700) 170-300HB	JC8015	0.15	0.2	10,940	5,470	0.15	0.25	8,750	6,130
Austenitic stainless steel (SUS304, 316, 317) 17Cr	JC8015	0.15	0.2	10,940	4,380	0.15	0.25	8,750	5,250
Ferritic & martensitic stainless steel (SUS403, 420J2, 430) 13Cr	JC8015	0.15	0.2	10,940	4,380	0.15	0.25	8,750	5,250
Titanium alloy (Ti-6Al-4V) 35-43HRC	JC8015	0.1	0.2	7,960	3,180	0.1	0.25	6,370	3,190
Heat resistant alloy (INCO718) 35-43HRC	JC8015	0.1	0.1	5,970	1,790	0.1	0.1	4,770	1,910
Aluminium alloy	FZ15	0.25	0.2	13,330	6,670	0.25	0.2	10,660	6,400

Note

1. Please adjust cutting conditions according to machine rigidity or work rigidity.
2. These parameters are for overhang length 3Dc. See right table for longer application.
3. In case of chatter occurring, recommended to reduce a_p or rpm and keep feed per tooth.
4. Use air blow.

Overhang (l/Dc)	n (min ⁻¹)	V_f (mm/min)
~ 3Dc	100%	100%
3Dc ~ 5Dc	70%	70%
5Dc ~ 10Dc	50%	50%

5-AXIS Series

■ Recommended cutting conditions



● TPM Type - with Barrel R

Material	Grade	Tool dia.(mm)							
		16				20			
		a_p (mm)	a_e (mm)	n (min^{-1})	V_f (mm/min)	a_p (mm)	a_e (mm)	n (min^{-1})	V_f (mm/min)
Carbon steel (S50C, S55C) below 250HB	JC8015	~4	0.15	13,930	4,180	~5	0.2	11,140	3,340
Cast steel (GM190, ICD5) below 285HB	JC8015	~4	0.15	13,930	4,180	~5	0.2	11,140	3,340
Tool & die steel (SKD61, SKD11) below 255HB	JC8015	~4	0.15	13,930	4,180	~5	0.2	11,140	3,340
Mold steel (HPM7, PX5, P20) 30-36 HRC	JC8015	~3.5	0.12	11,940	3,580	~4.5	0.1	9,550	2,870
Mold steel (NAK80, HPM1, P21) 38-43HRC	JC8015	~3	0.12	9,950	2,990	~4	0.1	7,960	2,390
Hardened die steel (SKD61, DAC, DHA) 42-52HRC	DH102	~2.5	0.1	6,960	1,390	~3	0.1	5,570	1,110
Hardened die steel (SKD11, SLD, DC11) 55-62HRC	DH102	~2	0.1	5,970	1,190	~2.5	0.1	4,770	950
Grey cast iron (FC250) 160-260HB	DH102	~4	0.15	13,930	5,570	~5	0.2	11,140	4,460
Nodular cast iron (FCD700) 170-300HB	DH102	~4	0.15	13,930	4,180	~5	0.2	11,140	3,340
Austenitic stainless steel (SUS304, 316, 317) 17Cr	JC8015	~3	0.12	11,940	3,580	~4	0.1	9,550	2,870
Ferritic & martensitic stainless steel (SUS403, 420J2, 430) 13Cr	JC8015	~3	0.12	11,940	3,580	~4	0.1	9,550	2,870
Titanium alloy (Ti-6Al-4V) 35-43HRC	JC8015	~2.5	0.1	5,970	1,190	~3	0.1	4,770	950
Heat resistant alloy (INCO718) 35-43HRC	JC8015	~2.5	0.1	3,980	800	~3	0.1	3,180	640

Please refer to chart and formula below to calculate a_p .

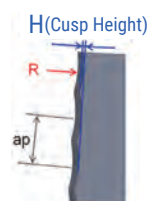

$$a_p = 2 \sqrt{(R^2 - (R - H)^2)}$$

Pick amount a_p (mm)		Cusp height (mm)									
Cat.No.	R	0.001	0.002	0.003	0.004	0.005	0.006	0.007	0.008	0.009	0.010
TPM-160-NR2T30BR400	400	1.79	2.53	3.10	3.58	4.00	4.38	4.73	5.06	5.73	5.66
TPM-200-NR2T30BR500	500	2.00	2.83	3.46	4.00	4.47	1.39	4.90	5.66	6.00	6.32

Note

1. Please adjust cutting conditions according to machine rigidity or work rigidity.
2. These parameters are for overhang length 3Dc. See right table for longer application.
3. In case of chatter occurring, recommended to reduce a_p or rpm and keep feed per tooth.
4. Use air blow.

Overhang (l/Dc)	n (min^{-1})	V_f (mm/min)
~ 3Dc	100%	100%
3Dc ~ 5Dc	70%	70%
5Dc ~ 10Dc	50%	50%

5-AXIS Series

Recommended cutting conditions



TPM Type - with Tip R

Material	Grade	Tool dia.(mm)							
		16				20			
		a_p (mm)	a_e (mm)	n (min^{-1})	V_f (mm/min)	a_p (mm)	a_e (mm)	n (min^{-1})	V_f (mm/min)
Carbon steel (S50C, S55C) below 250HB	JC8015	0.1	0.2	15,920	1,590	0.1	0.2	12,730	1,530
Cast steel (GM190, ICD5) below 285HB	JC8015	0.1	0.2	15,920	1,590	0.1	0.2	12,730	1,530
Tool & die steel (SKD61, SKD11) below 255HB	JC8015	0.1	0.2	15,920	1,590	0.1	0.2	12,730	1,530
Mold steel (HPM7, PX5, P20) 30-36 HRC	JC8015	0.1	0.2	14,920	1,490	0.1	0.2	11,940	1,430
Mold steel (NAK80, HPM1, P21) 38-43HRC	JC8015	0.1	0.2	13,930	1,390	0.1	0.2	11,140	1,110
Hardened die steel (SKD61, DAC, DHA) 42-52HRC	DH102	0.08	0.2	9,950	1,000	0.08	0.2	7,960	960
Hardened die steel (SKD11, SLD, DC11) 55-62HRC	DH102	0.08	0.2	8,950	900	0.08	0.2	7,160	860
Grey cast iron (FC250) 160-260HB	DH102	0.12	0.2	16,910	1,690	0.12	0.2	13,530	1,620
Nodular cast iron (FCD700) 170-300HB	DH102	0.12	0.2	15,920	1,590	0.12	0.2	12,730	1,530
Austenitic stainless steel (SUS304, 316, 317) 17Cr	JC8015	0.1	0.2	14,920	1,490	0.1	0.2	11,940	1,430
Ferritic & martensitic stainless steel (SUS403, 420J2, 430) 13Cr	JC8015	0.1	0.2	14,920	1,490	0.1	0.2	11,940	1,430
Titanium alloy (Ti-6Al-4V) 35-43HRC	JC8015	0.06	0.2	5,970	600	0.06	0.2	4,770	570
Heat resistant alloy (INCO718) 35-43HRC	JC8015	0.05	0.2	3,980	400	0.05	0.2	3,180	380

Note

1. Please adjust cutting conditions according to machine rigidity or work rigidity.
2. These parameters are for overhang length 3Dc. See right table for longer application.
3. In case of chatter occurring, recommended to reduce a_p or rpm and keep feed per tooth.
4. Use air blow.

Overhang (l/Dc)	n (min^{-1})	V_f (mm/min)
$\sim 3Dc$	100%	100%
$3Dc \sim 5Dc$	70%	70%
$5Dc \sim 10Dc$	50%	50%

5-AXIS Series

Recommended cutting conditions



LRM Type

Material	Grade	Tool dia.(mm)							
		16				20			
		a_p (mm)	a_e (mm)	n (min ⁻¹)	V_f (mm/min)	a_p (mm)	a_e (mm)	n (min ⁻¹)	V_f (mm/min)
Carbon steel (S50C, S55C) below 250HB	JC8015	0.15	~0.6	7,960	4,780	0.15	~0.7	6,370	4,460
Cast steel (GM190, ICD5) below 285HB	JC8015	0.15	~0.6	7,960	4,780	0.15	~0.7	6,370	4,460
Tool & die steel (SKD61, SKD11) below 255HB	JC8015	0.15	~0.6	7,960	4,780	0.15	~0.7	6,370	4,460
Mold steel (HPM7, PX5, P20) 30-36 HRC	JC8015	0.1	~0.6	7,960	3,980	0.1	~0.7	6,370	3,820
Mold steel (NAK80, HPM1, P21) 38-43HRC	JC8015	0.1	~0.6	6,960	3,480	0.1	~0.7	5,570	3,340
Hardened die steel (SKD61, DAC, DHA) 42-52HRC	DH102	0.1	~0.5	5,970	2,390	0.1	~0.6	4,770	2,390
Hardened die steel (SKD11, SLD, DC11) 55-62HRC	DH102	0.1	~0.5	4,970	1,990	0.1	~0.6	3,980	1,590
Hardened die steel (SKH, HAP) 55-62HRC	DH102	0.05	~0.25	3,980	1,190	0.05	~0.25	3,180	950
Grey cast iron (FC250) 160-260HB	DH102	0.15	~0.6	7,960	4,780	0.15	~0.7	6,370	4,460
Nodular cast iron (FCD700) 170-300HB	DH102	0.15	~0.6	6,960	4,180	0.15	~0.7	5,570	3,900
Austenitic stainless steel (SUS304, 316, 317) 17Cr	JC8015	0.15	~0.6	7,960	3,980	0.15	~0.7	6,370	3,820
Ferritic & martensitic stainless steel (SUS403, 420J2, 430) 13Cr	JC8015	0.15	~0.6	7,960	3,980	0.15	~0.7	6,370	3,820
Titanium alloy (Ti-6Al-4V) 35-43HRC	JC8015	0.1	~0.6	4,970	1,990	0.1	~0.7	3,980	1,990
Heat resistant alloy (INCO718) 35-43HRC	JC8015	0.1	~0.25	3,980	1,190	0.1	~0.3	3,180	1,270

Please refer to chart and formula below to calculate a_p .

$$a_e = 2 \sqrt{(R^2 - (R - H)^2)}$$

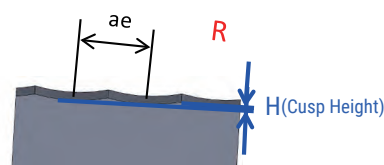

Pick amount a_p (mm)		Cusp height (mm)									
Cat.No.	R	0.001	0.002	0.003	0.004	0.005	0.006	0.007	0.008	0.009	0.010
LRM-160-R20-BR32	32	0.51	0.72	0.88	1.01	1.13	1.24	1.34	1.43	1.52	1.60
LRM-200-R30-BR40	40	0.57	0.80	0.98	1.13	1.26	1.39	1.50	1.60	1.70	1.79

Note

1. Please adjust cutting conditions according to machine rigidity or work rigidity.
2. These parameters are for overhang length 3Dc. See right table for longer application.
3. In case of chatter occurring, recommended to reduce a_p or rpm and keep feed per tooth.
4. Use air blow.

Overhang (l/Dc)	n (min ⁻¹)	V_f (mm/min)
~ 3Dc	100%	100%
5Dc ~ 10Dc	70%	70%
3Dc ~ 5Dc	50%	50%

5-AXIS Series

Recommended cutting conditions



LRM Type

Material	Grade	Tool dia.(mm)							
		25				30			
		a_p (mm)	a_e (mm)	n (min ⁻¹)	V_f (mm/min)	a_p (mm)	a_e (mm)	n (min ⁻¹)	V_f (mm/min)
Carbon steel (S50C, S55C) below 250HB	JC8015	0.15	~0.8	5,730	4,010	0.15	~0.8	4,770	3,340
Cast steel (GM190, ICD5) below 285HB	JC8015	0.15	~0.8	5,730	4,010	0.15	~0.8	4,770	3,340
Tool & die steel (SKD61, SKD11) below 255HB	JC8015	0.15	~0.8	5,730	4,010	0.15	~0.8	4,770	3,340
Mold steel (HPM7, PX5, P20) 30-36 HRC	JC8015	0.1	~0.8	5,730	3,440	0.1	~0.8	4,770	2,860
Mold steel (NAK80, HPM1, P21) 38-43HRC	JC8015	0.1	~0.8	5,090	3,050	0.1	~0.8	4,240	2,540
Hardened die steel (SKD61, DAC, DHA) 42-52HRC	DH102	0.1	~0.7	4,460	2,230	0.1	~0.7	3,710	1,860
Hardened die steel (SKD11, SLD, DC11) 55-62HRC	DH102	0.1	~0.7	3,820	1,530	0.1	~0.7	3,180	1,270
Hardened die steel (SKH,HAP) 55-62HRC	DH102	0.05	~0.25	2,550	770	0.05	~0.25	2,120	640
Grey cast iron (FC250) 160-260HB	DH102	0.15	~0.8	5,730	4,010	0.15	~0.8	4,770	3,340
Nodular cast iron (FCD700) 170-300HB	DH102	0.15	~0.8	5,730	4,010	0.15	~0.8	4,770	3,340
Austenitic stainless steel (SUS304, 316, 317) 17Cr	JC8015	0.15	~0.8	5,730	3,440	0.15	~0.8	4,770	2,860
Ferritic & martensitic stainless steel (SUS403, 420J2, 430) 13Cr	JC8015	0.15	~0.8	5,730	3,440	0.15	~0.8	4,770	2,860
Titanium alloy (Ti-6Al-4V) 35-43HRC	JC8015	0.1	~0.8	3,180	1,590	0.1	~0.8	2,650	1,330
Heat resistant alloy (INCO718) 35-43HRC	JC8015	0.1	~0.3	2,550	1,020	0.1	~0.3	2,120	850

Please refer to chart and formula below to calculate a_p .

$$a_e = 2 \sqrt{(R^2 - (R - H)^2)}$$

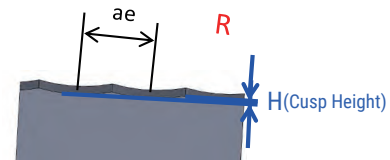

Pick amount a_p (mm)		Cusp height (mm)									
Cat.No.	R	0.001	0.002	0.003	0.004	0.005	0.006	0.007	0.008	0.009	0.010
LRM-250-R30-BR50	50	0.63	0.89	1.10	1.26	1.41	1.55	1.67	1.79	1.90	2.00
LRM-300-R30-BR60	60	0.69	0.98	1.20	1.39	1.55	1.70	1.83	1.96	2.08	2.19

Note

- Please adjust cutting conditions according to machine rigidity or work rigidity.
- These parameters are for overhang length 3Dc. See right table for longer application.
- In case of chatter occurring, recommended to reduce a_p or rpm and keep feed per tooth.
- Use air blow.

Overhang (l/Dc)	n (min ⁻¹)	V_f (mm/min)
~ 3Dc	100%	100%
5Dc ~ 10Dc	70%	70%
3Dc ~ 5Dc	50%	50%

5-AXIS Series

Recommended cutting conditions



STLP Type - with Barrel R

Material		Tool dia. (mm)								
		16			20			25		
		ℓ (mm)	n (min ⁻¹)	V _f (mm/min)	ℓ (mm)	n (min ⁻¹)	V _f (mm/min)	ℓ (mm)	n (min ⁻¹)	V _f (mm/min)
Carbon steel (S50C, S55C) below 250HB		70	10,000	3,200~4,000	70	8,000	2,600~3,200	70	6,400	2,000~2,600
		110	8,800	2,500~3,200	125	7,200	2,000~2,600	140	5,700	2,000~2,600
		150	7,800	1,900~2,500	175	6,400	1,600~2,100	200	5,100	1,200~1,600
Alloy steel, Tool & die steel, Mold steel (SKD, SKH, NAK) below 42HRC		70	10,000	2,400~3,200	70	8,000	2,000~2,600	70	6,400	1,500~2,000
		110	8,800	1,800~2,500	125	7,200	1,500~2,100	140	5,700	1,100~1,600
		150	7,800	1,300~1,900	175	6,400	1,300~1,600	200	5,100	800~1,200
Hardened die steel (SKD61, DAC, DHA) 42-52HRC		70	10,000	2,000~2,800	70	8,000	1,600~2,300	70	5,100	600~1,000
		110	8,800	1,400~2,100	125	7,200	1,200~1,800	140	4,500	500~700
		150	7,800	1,000~1,600	175	6,400	800~1,300	200	3,800	300~600
Austenitic stainless steel (SUS304, 316, 317) 17Cr		70	10,000	2,000~2,800	70	8,000	1,600~2,300	70	6,400	1,300~1,800
		110	8,800	1,400~2,100	125	7,200	1,200~1,800	140	5,700	900~1,400
		150	7,800	1,000~1,600	175	6,400	800~1,300	200	5,100	600~1,000
Titanium alloy (Ti-6Al-4V) 35-43HRC		70	8,000	1,000~1,600	70	6,400	800~1,200	70	5,100	800~1,200
		110	7,000	800~1,400	125	5,600	700~900	140	4,500	700~900
		150	6,000	500~1,000	175	4,800	400~800	200	3,800	400~800
Heat resistant alloy (INCO718) 35-43HRC		70	4,000	320~480	70	3,200	260~380	70	2,500	200~300
		110	3,500	280~420	125	2,800	220~340	140	2,200	180~260
		150	3,000	240~360	175	2,400	190~290	200	1,900	150~230

Please refer to chart and formula below to calculate a_p .

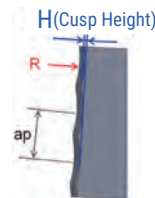

$$a_p = 2 \sqrt{(R^2 - (R - H)^2)}$$

Pick amount a_p (mm)		Cusp height (mm)									
Cat.No.	R	0.001	0.002	0.003	0.004	0.005	0.006	0.007	0.008	0.009	0.010
STLP-4160T20R4-M8	1500										
STLP-4200T15R4-M10		3.46	4.90	6.00	6.93	7.75	8.49	9.17	9.80	10.39	10.95
STLP-4200T20R5-M10											
STLP-4250T20R5-M12	2200	4.20	5.93	7.27	8.39	9.38	10.28	11.10	11.87	12.59	13.27

Note

1. Please apply coolant according to work material.
2. In case of chatter occurring, recommended to reduce a_p or rpm and keep feed per tooth.
3. In case of machine rpm not enough, reduce V_f at same rate.

5-AXIS Series

Recommended cutting conditions



STLP Type - with Tip R

Material			Tool dia.(mm)								
			16			20			25		
			ℓ (mm)	n (min^{-1})	V_f (mm/min)	ℓ (mm)	n (min^{-1})	V_f (mm/min)	ℓ (mm)	n (min^{-1})	V_f (mm/min)
Carbon steel (S50C, S55C) below 250HB		$ap \leq 0.4$ $ae \leq 0.25$	70	7,800	1,090~1,400	70	6,300	880~1,100	70	5,100	710~920
			110	7,100	850~1,100	125	5,700	680~910	140	4,600	550~740
			150	6,300	630~880	175	5,000	500~700	200	4,100	410~570
Alloy steel, Tool & die steel, Mold steel (SKD, SKH, NAK) below 42HRC		$ap \leq 0.4$ $ae \leq 0.25$	70	7,800	780~1,090	70	6,300	630~880	70	5,100	510~710
			110	7,100	560~850	125	5,700	450~680	140	4,600	370~550
			150	6,300	440~690	175	5,000	350~550	200	4,100	290~450
Hardened die steel (SKD61, DAC, DHA) 42-52HRC		$ap \leq 0.3$ $ae \leq 0.2$	70	6,300	310~560	70	5,000	250~400	70	4,100	210~370
			110	5,500	270~380	125	4,400	220~290	140	3,600	180~250
			150	4,700	180~320	175	3,800	140~260	200	3,100	120~220
Austenitic stainless steel (SUS304, 316, 317) 17Cr		$ap \leq 0.3$ $ae \leq 0.2$	70	7,800	700~930	70	6,300	560~750	70	5,100	460~610
			110	7,100	490~780	125	5,700	390~620	140	4,600	320~510
			150	6,300	310~560	175	5,000	250~450	200	4,100	210~370
Titanium alloy (Ti-6Al-4V) 35-43HRC		$ap \leq 0.3$ $ae \leq 0.2$	70	5,900	230~470	70	4,700	180~370	70	3,800	150~300
			110	5,100	200~350	125	4,100	160~280	140	3,300	130~230
			150	4,300	170~300	175	3,500	140~240	200	2,800	110~200
Heat resistant alloy (INCO718) 35-43HRC		$ap \leq 0.2$ $ae \leq 0.15$	70	4,000	320~480	70	3,200	260~380	70	2,500	100~130
			110	3,500	280~420	125	2,800	220~340	140	2,200	90~110
			150	3,000	240~360	175	2,400	190~290	200	1,900	80~100

Note

1. Please apply coolant according to work material.
2. In case of chatter occurring, recommended to reduce ap or rpm and keep feed per tooth.
3. In case of machine rpm not enough, reduce V_f at same rate.

5-AXIS Series



Recommended cutting conditions

FJVA Type - with Barrel R

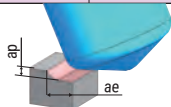
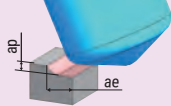
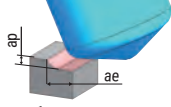
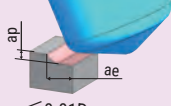
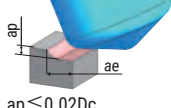
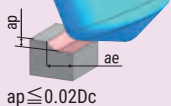
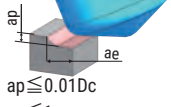
Material	ap (mm)	ae (mm)	Tool dia.(mm)							
			6		8		10		12	
			n (min ⁻¹)	V _f (mm/min)	n (min ⁻¹)	V _f (mm/min)	n (min ⁻¹)	V _f (mm/min)	n (min ⁻¹)	V _f (mm/min)
Carbon steel (S50C, S55C) below 250HB	 ap ≤ 0.3 ae ≤ 3		15,920	2,550	13,930	2,510	12,730	2,550	10,610	2,120
Alloy steel, Tool & die steel, Mold steel (SKD, SKH, NAK) below 42HRC	 ap ≤ 0.3 ae ≤ 3		10,610	1,270	9,950	1,390	9,550	1,530	7,960	1,270
Hardened die steel (SKD61, DAC, DHA) 42-52HRC	 ap ≤ 0.02Dc ae ≤ 2.5		8,490	850	7,960	960	7,640	1,070	6,370	890
Hardened die steel (SKD11, SL, DC11) 55-62HRC	 ap ≤ 0.01Dc ae ≤ 2		6,900	550	6,370	640	6,050	730	5,040	600
Austenitic stainless steel (SUS304, 316, 317) 17Cr	 ap ≤ 0.02Dc ae ≤ 2		10,610	1,060	9,950	1,190	9,550	1,340	7,960	1,110
Titanium alloy (Ti-6Al-4V)	 ap ≤ 0.02Dc ae ≤ 2		5,310	420	4,770	480	4,140	500	3,450	410
Heat resistant alloy (INCO718) 35-43HRC	 ap ≤ 0.01Dc ae ≤ 1		3,180	250	2,790	220	2,550	200	2,120	170

Please refer to chart and formula below to calculate ap.

$$ae = 2 \sqrt{(R^2 - (R - H)^2)}$$

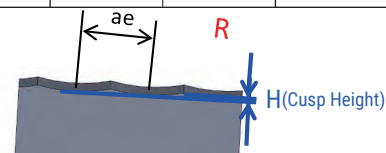

Pick amount ap(mm)		Cusp height (mm)									
Cat.No.	R	0.001	0.002	0.003	0.004	0.005	0.006	0.007	0.008	0.009	0.010
FJVA4060S06-R250	250										
FJVA4080S08-R250											
FJVA4100S10-R250		1.41	2.00	2.45	2.83	3.16	3.46	3.74	4.00	4.24	4.47
FJVA4120S12-R250											

Note

1. Please apply coolant according to work material.
2. In case of chatter occurring, recommended to reduce ap or rpm and keep feed per tooth.
3. In case of machine rpm not enough, reduce Vf at same rate.

5-AXIS Series

■ Definition of edge shape for programming

● When using taper holder (MQT-***A03/05 type)

Fig.1 XPHW/T

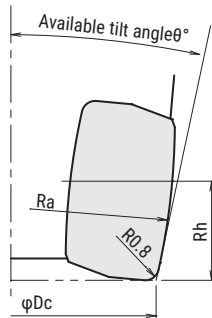
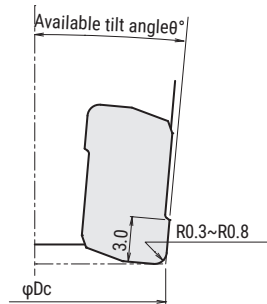

Fig.2 YPHW



● Dimensions when using XPHW / T insert

available tilt angle	Cat.No	Dimensions (mm)			Fig
		ϕDc	Ra	Rh	
1°~6°	MQT-2016A03-M8	15.5	R64.19	8.76	1
3°~8°	MQT-2016A05-M8	15.5	R64.34	10.98	1
1°~6°	MQT-2020A03-M10	19.5	R63.34	8.67	1
3°~8°	MQT-2020A05-M10	19.5	R63.46	10.85	1

● Dimensions when using YPHW insert

available tilt angle	Cat.No	Dimensions (mm)		Fig
		ϕDc		
3°	MQT-2016A03-M8	16		2
5°	MQT-2016A05-M8	16		2
3°	MQT-2020A03-M10	20		2
5°	MQT-2020A05-M10	20		2

● When using straight holder (MQT-***A00 type)

Fig.3 XPHW/T

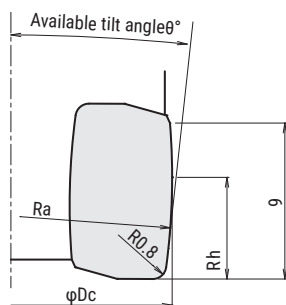

● Dimensions when using XPHW/T insert

available tilt angle	Cat.No	Dimensions (mm)			Fig
		ϕDc	Ra	Rh	
0°~3°	MQT-2016A00-M8	16	R63.27	5.48	3
0°~3°	MQT-4020A00-M10	20	R64.29	5.48	3
0°~3°	MQT-5025A00-M12	25	R63.26	5.48	3
0°~3°	MQT-6032A00-M16	32	R62.41	5.48	3
0°~3°	MQT-6035A00-M16	35	R62.16	5.48	3

● Dimensions when using YPHW insert

available tilt angle	Cat.No	Dimensions (mm)		Fig
		ϕDc		
0°	MQT-2016A00-M8	16		-
0°	MQT-4020A00-M10	20		-
0°	MQT-5025A00-M12	25		-
0°	MQT-6032A00-M16	32		-
0°	MQT-6035A00-M16	35		-

5-AXIS Series

Recommended cutting conditions

MQT type with XPHT/XPHW insert for finishing side wall + MSN shank

Material	Grade	Tool dia.(mm)														
		16					20					20				
		2N					2N					4N				
r (mm)	a_p (mm)	a_e (mm)	n (min ⁻¹)	V_f (mm/min)	r (mm)	a_p (mm)	a_e (mm)	n (min ⁻¹)	V_f (mm/min)	r (mm)	a_p (mm)	a_e (mm)	n (min ⁻¹)	V_f (mm/min)		
Carbon steel (S50C, S55C) below 250HB	JC8015 XPHT (XPHW)	~55	≤1.5	<0.12	12,000	4,800	~70	≤1.5	<0.12	9,600	3,840	~70	≤1.5	<0.12	9,600	7,680
	(CX75)	55~80	≤1.2	<0.10	9,000	3,600	70~100	≤1.2	<0.10	7,200	2,880	70~100	≤1.2	<0.10	7,200	5,760
		80~105	≤1.0	<0.10	7,200	2,880	100~130	≤1.0	<0.10	5,760	2,300	100~130	≤1.0	<0.10	5,760	4,600
		105~160	≤1.0	<0.10	6,000	2,400	130~200	≤1.0	<0.10	4,800	1,920	130~200	≤1.0	<0.10	4,800	3,840
Tool & die steel (SKD61, SKD11) below 255HB	JC8015 XPHT (XPHW)	~55	≤1.5	<0.12	10,000	4,000	~70	≤1.5	<0.12	8,000	3,200	~70	≤1.5	<0.12	8,000	6,400
	(CX75)	55~80	≤1.2	<0.10	7,500	3,000	70~100	≤1.2	<0.10	6,000	2,400	70~100	≤1.2	<0.10	6,000	4,800
		80~105	≤1.0	<0.10	6,000	2,400	100~130	≤1.0	<0.10	4,800	1,920	100~130	≤1.0	<0.10	4,800	3,840
		105~160	≤1.0	<0.10	5,000	2,000	130~200	≤1.0	<0.10	4,000	1,600	130~200	≤1.0	<0.10	4,000	3,200
Mold steel (HPM7, PX5, P20) 30-36 HRC	JC8015 XPHT (XPHW)	~55	≤1.2	<0.12	9,000	3,600	~70	≤1.2	<0.12	7,200	2,880	~70	≤1.2	<0.12	7,200	5,760
	(DH102)	55~80	≤1.0	<0.10	6,800	2,720	70~100	≤1.0	<0.10	5,400	2,160	70~100	≤1.0	<0.10	5,400	4,320
		80~105	≤0.8	<0.10	5,400	2,160	100~130	≤0.8	<0.10	4,320	1,730	100~130	≤0.8	<0.10	4,320	3,460
		105~160	≤0.8	<0.10	4,500	1,800	130~200	≤0.8	<0.10	3,600	1,440	130~200	≤0.8	<0.10	3,600	2,880
Mold steel (NAK80, HPM1, P21) 38-43HRC	DH102 XPHW	~55	≤1.0	<0.12	8,000	3,200	~70	≤1.0	<0.12	6,400	2,560	~70	≤1.0	<0.12	6,400	5,120
	(JC8015)	55~80	≤0.8	<0.10	6,000	2,400	70~100	≤0.8	<0.10	4,800	1,920	70~100	≤0.8	<0.10	4,800	3,840
		80~105	≤0.6	<0.10	4,800	1,920	100~130	≤0.6	<0.10	3,840	1,540	100~130	≤0.6	<0.10	3,840	3,080
		105~160	≤0.6	<0.10	4,000	1,600	130~200	≤0.6	<0.10	3,200	1,280	130~200	≤0.6	<0.10	3,200	2,560
Hardened die steel (SKD61, DAC, DHA) 42-52HRC	DH102 XPHW	~55	≤1.0	<0.10	5,000	1,500	~70	≤1.0	<0.10	4,000	1,200	~70	≤1.0	<0.10	4,000	2,400
	(JC8015)	55~80	≤0.8	<0.08	3,750	1,130	70~100	≤0.8	<0.08	3,000	900	70~100	≤0.8	<0.08	3,000	1,800
		80~105	≤0.6	<0.08	3,000	900	100~130	≤0.6	<0.08	2,400	720	100~130	≤0.6	<0.08	2,400	1,440
		105~160	≤0.6	<0.08	2,500	750	130~200	≤0.6	<0.08	2,000	600	130~200	≤0.6	<0.08	2,000	1,200
Hardened die steel (SKD11, SLD, DC11) 55-62HRC	DH102 XPHW	~55	≤1.0	<0.10	3,600	720	~70	≤1.0	<0.10	2,860	570	~70	≤1.0	<0.10	2,860	1,140
	(JC8015)	55~80	≤0.8	<0.08	2,700	540	70~100	≤0.8	<0.08	2,140	430	70~100	≤0.8	<0.08	2,140	860
		80~105	≤0.6	<0.08	2,160	430	100~130	≤0.6	<0.08	1,720	340	100~130	≤0.6	<0.08	1,720	680
		105~160	≤0.6	<0.08	1,800	360	130~200	≤0.6	<0.08	1,430	290	130~200	≤0.6	<0.08	1,430	580
Grey & Nodular cast iron (FC, FCD) below 300HB	JC8015 XPHW (XPHT)	~55	≤1.5	<0.12	12,000	6,000	~70	≤1.5	<0.12	9,600	4,800	~70	≤1.5	<0.12	9,600	9,600
	(DH102)	55~80	≤1.2	<0.10	9,000	4,500	70~100	≤1.2	<0.10	7,200	3,600	70~100	≤1.2	<0.10	7,200	7,200
		80~105	≤1.0	<0.10	7,200	3,600	100~130	≤1.0	<0.10	5,760	2,880	100~130	≤1.0	<0.10	5,760	5,760
		105~160	≤1.0	<0.10	6,000	3,000	130~200	≤1.0	<0.10	4,800	2,400	130~200	≤1.0	<0.10	4,800	4,800
Stainless steel (SUS304) below 250HB	JC8015 XPHT (XPHW)	~55	≤1.2	<0.12	10,000	4,000	~70	≤1.2	<0.12	8,000	3,200	~70	≤1.2	<0.12	8,000	6,400
	(JC8015)	55~80	≤1.0	<0.10	7,500	3,000	70~100	≤1.0	<0.10	6,000	2,400	70~100	≤1.0	<0.10	6,000	4,800
		80~105	≤0.8	<0.10	6,000	2,400	100~130	≤0.8	<0.10	4,800	1,920	100~130	≤0.8	<0.10	4,800	3,840
		105~160	≤0.8	<0.10	5,000	2,000	130~200	≤0.8	<0.10	4,000	1,600	130~200	≤0.8	<0.10	4,000	3,200

Cusp height: XPHT/W

Cusp Height (μm)	a_p (mm)	Cusp Height (μm)	a_p (mm)
0.50	0.5	3.35	1.3
0.71	0.6	3.89	1.4
0.97	0.7	4.46	1.5
1.27	0.8	5.08	1.6
1.61	0.9	5.73	1.7
1.98	1.0	6.43	1.8
2.40	1.1	7.16	1.9
2.86	1.2	7.94	2.0

Note

- Figures to be adjusted according to machine rigidity or work rigidity.
- If chattering occurs, recommended to reduce a_p and a_e .
- Use air blow.

5-AXIS Series

■ Recommended cutting conditions

MQT type with XPHT/XPHW insert for finishing side wall + MSN shank

Material	Grade	Tool dia.(mm)									
		25					32/35				
		5N					6N				
		r (mm)	a _p (mm)	a _e (mm)	n (min ⁻¹)	V _f (mm/min)	r (mm)	a _p (mm)	a _e (mm)	n (min ⁻¹)	V _f (mm/min)
Carbon steel (S50C, S55C) below 250HB	JC8015 XPHT (XPHW) (CX75)	~90	≤1.5	<0.12	7,640	7,640	~120	≤1.5	<0.12	5,460	6,550
		90~125	≤1.2	<0.10	5,730	5,730	120~175	≤1.2	<0.10	4,100	4,920
		125~160	≤1.0	<0.10	4,580	4,580	175~225	≤1.0	<0.10	3,280	3,940
		160~250	≤1.0	<0.10	3,820	3,820	225~320	≤1.0	<0.10	2,730	3,280
Tool & die steel (SKD61, SKD11) below 255HB	JC8015 XPHT (XPHW) (CX75)	~90	≤1.5	<0.12	6,400	6,400	~120	≤1.5	<0.12	4,550	5,460
		90~125	≤1.2	<0.10	4,800	4,800	120~175	≤1.2	<0.10	3,410	4,090
		125~160	≤1.0	<0.10	3,840	3,840	175~225	≤1.0	<0.10	2,730	3,280
		160~250	≤1.0	<0.10	3,200	3,200	225~320	≤1.0	<0.10	2,280	2,740
Mold steel (HPM7, PX5, P20) 30-36 HRC	JC8015 XPHT (XPHW) (DH102)	~90	≤1.2	<0.12	5,730	5,730	~120	≤1.2	<0.12	4,090	4,910
		90~125	≤1.0	<0.10	4,300	4,300	120~175	≤1.0	<0.10	3,070	3,680
		125~160	≤0.8	<0.10	3,440	3,440	175~225	≤0.8	<0.10	2,450	2,940
		160~250	≤0.8	<0.10	2,870	2,870	225~320	≤0.8	<0.10	2,050	2,460
Mold steel (NAK80, HPM1, P21) 38-43HRC	DH102 XPHW (JC8015)	~90	≤1.0	<0.12	5,100	5,100	~120	≤1.0	<0.12	3,640	4,370
		90~125	≤0.8	<0.10	3,830	3,830	120~175	≤0.8	<0.10	2,730	3,280
		125~160	≤0.6	<0.10	3,060	3,060	175~225	≤0.6	<0.10	2,180	2,620
		160~250	≤0.6	<0.10	2,550	2,550	225~320	≤0.6	<0.10	1,820	2,180
Hardened die steel (SKD61, DAC, DHA) 42-52HRC	DH102 XPHW (JC8015)	~90	≤1.0	<0.10	3,180	2,380	~120	≤1.0	<0.10	2,280	2,050
		90~125	≤0.8	<0.08	2,380	1,780	120~175	≤0.8	<0.08	1,710	1,540
		125~160	≤0.6	<0.08	1,910	1,430	175~225	≤0.6	<0.08	1,370	1,230
		160~250	≤0.6	<0.08	1,590	1,190	225~320	≤0.6	<0.08	1,140	1,030
Hardened die steel (SKD11, SLD, DC11) 55-62HRC	DH102 XPHW	~90	≤1.0	<0.10	2,300	1,150	~120	≤1.0	<0.10	1,640	980
		90~125	≤0.8	<0.08	1,720	860	120~175	≤0.8	<0.08	1,230	740
		125~160	≤0.6	<0.08	1,380	690	175~225	≤0.6	<0.08	980	590
		160~250	≤0.6	<0.08	1,150	580	225~320	≤0.6	<0.08	820	490
Grey & Nodular cast iron (FC, FCD) below 300HB	JC8015 XPHW (XPHT) (DH102)	~90	≤1.5	<0.12	7,640	9,550	~120	≤1.5	<0.12	5,460	8,190
		90~125	≤1.2	<0.10	5,730	7,160	120~175	≤1.2	<0.10	4,100	6,150
		125~160	≤1.0	<0.10	4,580	5,720	175~225	≤1.0	<0.10	3,280	4,920
		160~250	≤1.0	<0.10	3,820	4,780	225~320	≤1.0	<0.10	2,730	4,100
Stainless steel (SUS304) below 250HB	JC8015 XPHT (XPHW)	~90	≤1.2	<0.12	6,400	6,400	~120	≤1.2	<0.12	4,550	5,460
		90~125	≤1.0	<0.10	4,800	4,800	120~175	≤1.0	<0.10	3,410	4,090
		125~160	≤0.8	<0.10	3,840	3,840	175~225	≤0.8	<0.10	2,730	3,280
		160~250	≤0.8	<0.10	3,200	3,200	225~320	≤0.8	<0.10	2,280	2,740

Cusp height: XPHT/W

Cusp Height (μm)	a _p (mm)	Cusp Height (μm)	a _p (mm)
0.50	0.5	3.35	1.3
0.71	0.6	3.89	1.4
0.97	0.7	4.46	1.5
1.27	0.8	5.08	1.6
1.61	0.9	5.73	1.7
1.98	1.0	6.43	1.8
2.40	1.1	7.16	1.9
2.86	1.2	7.94	2.0

Note

- Figures to be adjusted according to machine rigidity or work rigidity.
- If chattering occurs, recommended to reduce ap and ae.
- Use air blow.

SKS-GII

SKG/MSG Type



High metal removal rate

Feature 1

Provides stability even milling of deep cavities.

Feature 2

4 corner positive insert with low cutting forces.



SKS-GII **SKG/MSG Type**

Feature 3 Flat top insert

SKG-10 type insert : Max ap=1.5mm

SKG-14 type insert : Max ap=2.5mm



Feature 4 Chip breaker insert

Optimized cutting edge for machining of difficult to cut materials like titanium alloy.

Effective for machining that requires reduced cutting loads or long overhang application.



SM breaker for difficult to cut materials



PM breaker for mold steel

Feature 5

Insert grades for a wide range of materials

<JC8118> <JC8050> <JC7550> <DS150>



mold steel, hardened steel from 38HRC upto 50HRC
JC8118



mold steel, general steel below 36HRC
JC8050



Titanium alloy, stainless steel
JC7550, DS150

ISO	P					M					K				S				H		
	P01	P10	P20	P30	P40	M01	M10	M20	M30	M40	K01	K10	K20	K30	S01	S10	S20	S30	H01	H10	H20
Range			JC8118									JC8118					DS150			JC8118	
			JC8050															JC7550			

Feature 6

Excellent chip evacuation

SKS-GII

SKG/MSG Type

SKG10
TYPE

Bore Type

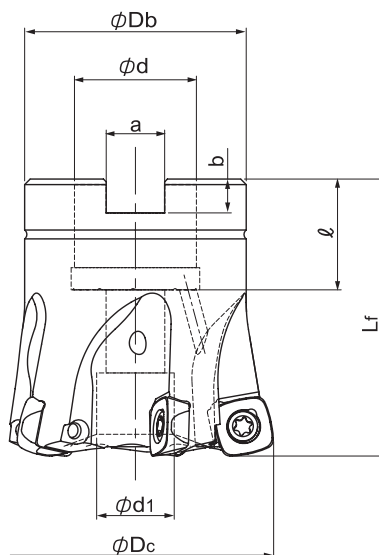

Cat.No.	Stock	No. of inserts	Dimensions (mm)								Arbor set bolt	Weight (kg)	Inserts
			ϕD_c	L_f	ϕD_b	ϕd	ϕd_1	a	b	l			
SKG-4050R-10-22	●	4	50	50	40	22	14	10.4	6.3	20	M10X1.5X35*	0.3	SPNW10 SPET10 SPMT10
SKG-5050R-10-22	●	5					52				16.6	M10X1.5X35*	
SKG-5052R-10-22	●		63			48	17	M10	0.5				
SKG-5063R-10-22	○				27		20	12.4	7	22	M12X1.75X30*	0.5	
SKG-5063R-10-27	○	6	63		48	22	17	10.4	6.3	20	M10	0.5	
SKG-6063R-10-22	●			27		20	12.4	7	22	M12X1.75X30*	0.5		
SKG-6063R-10-27	●		66	50	27	20	12.4	7	22	M12X1.75X30*	0.6		
SKG-6066R-10-27	●									80	60	M12X1.75X30*	
SKG-6080R-10-27	●												

Screw	Torque(N.m)	Wrench
TSW-3509H	3.0	A-15T

MSG10
TYPE

Modular Type

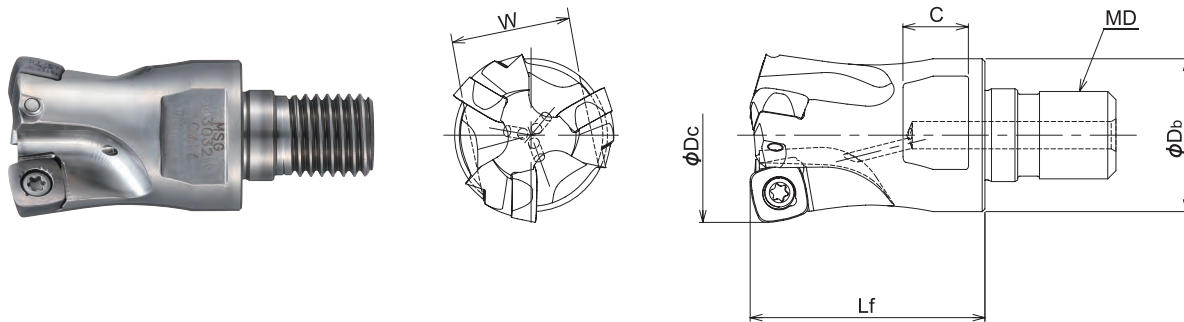

Cat.No.	Stock	No. of inserts	Dimensions (mm)						Insert
			ϕD_c	L_f	ϕD_b	MD	C	W	
MSG-2025-10-M12	●	2	25	35	23	M12	11	19	SPNW10 SPET10 SPMT10
MSG-3032-10-M16	●	3	32	43	28	M16	12	22	
MSG-3035-10-M16	○		35		14		26		
MSG-4040-10-M16	●	4	40		32				
MSG-4042-10-M16	●		42						

Screw	Torque(N.m)	Wrench
TSW-3509H	3.0	A-15

SKS-GII **SKG/MSG Type**

SKG/MSG10
TYPE

Insert



Fig. 1

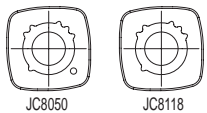
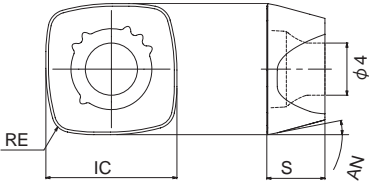

Fig. 2

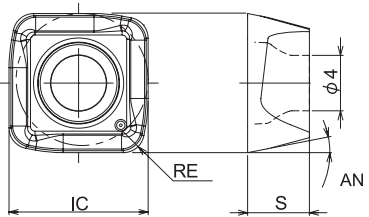

Fig. 3

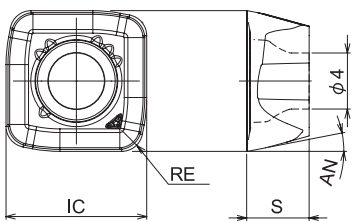
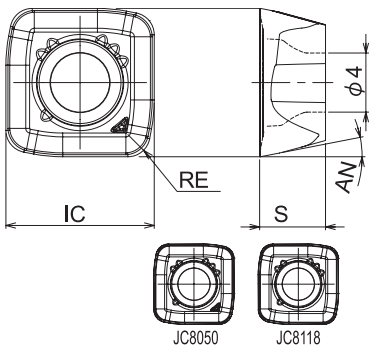

Fig. 4



Cat.No.	Tolerance	PVD Coating				Dimensions (mm)				Fig.
		DS150	JC7550	JC8050	JC8118	RE	IC	S	AN	
SPNW100415ZTR	N			●	●	1.5	10	4.46	11°	1
SPET100415ZPER-SM	E	●	●							2
SPMT100415ZPER-SM	M	●	●							3
SPMT100415ZPTR-PM				●	●					4

SKG14
TYPE

Bore Type

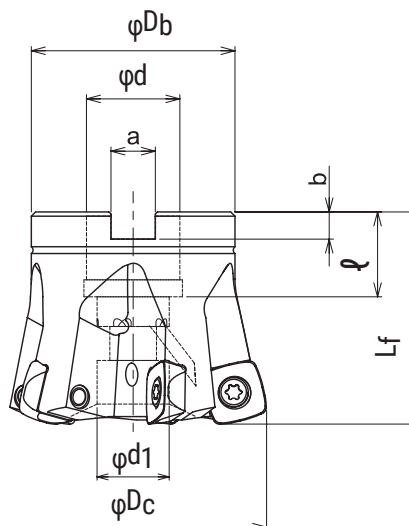

Cat.No.	Stock	No. of inserts	Dimensions (mm)								Arbor set bolt	Weight (kg)	Insert
			φDc	Lf	φDb	φd	φd1	a	b	φ			
SKG-4050R-14-22	●	4	50	50	40	22	14	10.4	6.3	19.05	M10X1.5X35*	0.3	SPNW14 SPMT14
SKG-4052R-14-22	●		52		42		17				M10X1.5X35*	0.3	
SKG-4063R-14-22	●		63		48	20	M10	0.5					
SKG-4063R-14-27	●		80		60		M12X1.75X35*	0.5					
SKG-5066R-14-27	●	5	66	50	27	20	12.4	7	22	M12X1.75X35*	0.5		
SKG-5080R-14-27	●		80	60	37	M12X1.75X35*	0.8						
SKG-6100R-14-32	●	6	100	63	70	32	45	14.4	8	25	M16	1.6	

Screw	Torque(N.m)	Wrench
CSW-513H	5.5	A-20

SKS-GII **SKG/MSG Type**

SKG14
TYPE

Insert

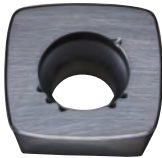

Fig. 1

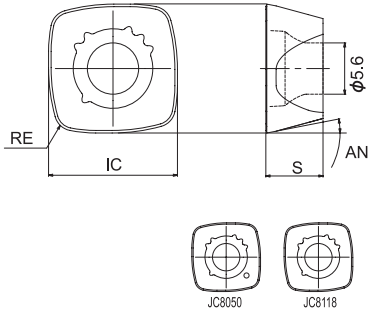

Fig. 2

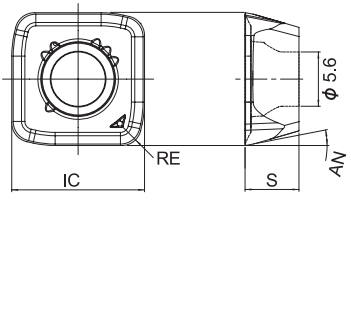
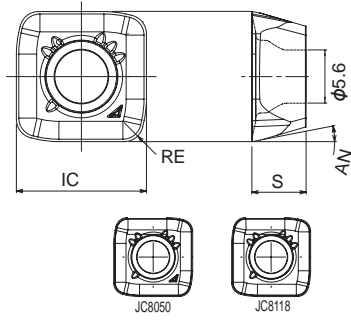

Fig. 3



Cat.No.	Tolerance	PVD Coating				Dimensions (mm)				Fig.
		DS150	JC7550	JC8050	JC8118	RE	IC	S	AN	
SPNW140515ZTR	N			●	●	1.5	13.7	5.56	11°	1
SPMT140520ZPER-SM	M	●	●			2				2
SPMT140520ZPTR-PM				●	●					3

■ Definition of corner shape for programming

● SPNW100415ZTR

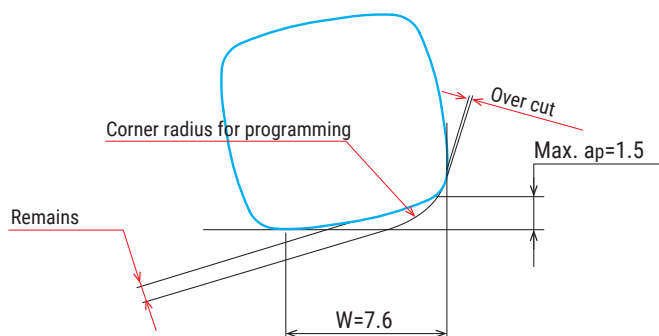

Corner radius for programming	Over cut	Remains
R2.5	0	0.99
R3.0 (Standard)	0	0.84
R3.5	0.09	0.71
R4.0	0.23	0.59

● SPE(M)T100415ZPER-SM
SPMT100415ZPTR-PM

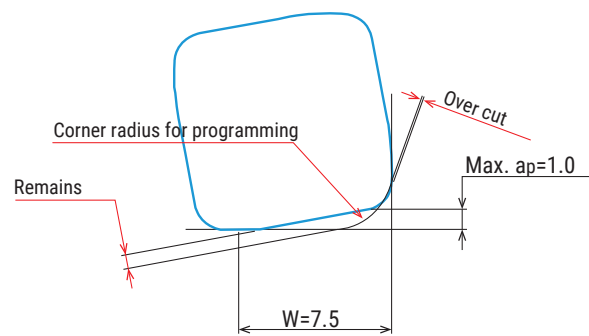

Corner radius for programming	Over cut	Remains
R2.5 (Standard)	0	0.77
R3.0	0.09	0.68
R3.5	0.25	0.60
R4.0	0.43	0.52

● SPNW140515ZTR

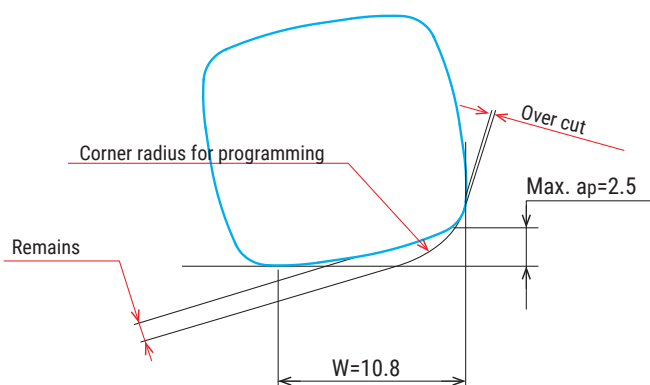

Corner radius for programming	Over cut	Remains
R3.5	0	1.60
R4.0 (Standard)	0	1.46
R4.5	0.06	1.32
R5.0	0.17	1.19

● SPMT140520ZPER-SM
SPMT140520ZPTR-PM

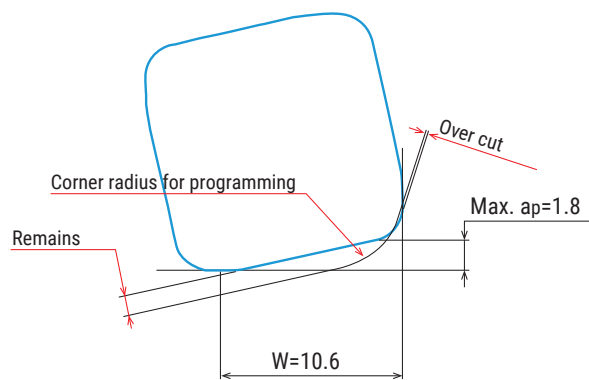

Corner radius for programming	Over cut	Remains
R3.5 (Standard)	0	1.35
R4.0	0.02	1.25
R4.5	0.14	1.12
R5.0	0.29	1.05

Recommended Data for Profile Milling

Ramping

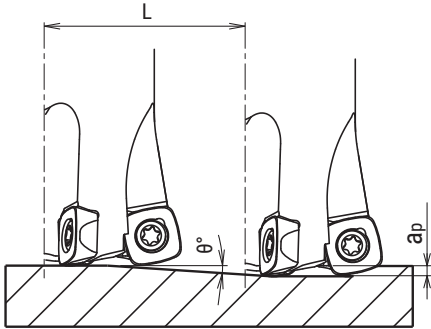

Helical interpolation

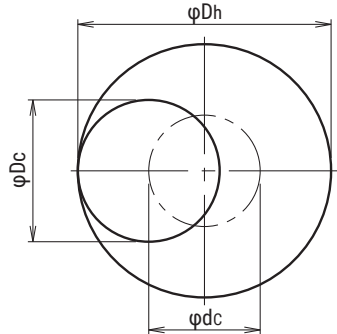

- Calculation of tool pass dia.

$$\varphi_{Dc} = \varphi_{Dh} - \varphi_{Dc}$$

Tool pass dia. Bore dia. Tool Dia.

- Depth of cut per one circuit should not exceed max. depth of cut A_p
- Down cutting is recommended, tool pass rotation should be counterclockwise

- In case of ramping and helical interpolation, apply 70% or less feed (V_f) from standard cutting condition table.

● SPNW100415ZTR / SPNW140515ZTR

Cat.No.	Tool dia. (mm)	Effective Cutting dia. (mm)	Max. depth of cut: a_p (mm)	Ramping		Helical interpolation	
				Max. ramping angle θ	Total cutting length at Max. (a_p): L (mm)	Min. Bore dia. D_h min. (mm)	Max. Bore dia. D_h max. (mm)
MSG-2025-10	25	9.8	1.5	1°	85.9	36	48
MSG-3032-10	32	16.8	1.5	1°	85.9	50	62
MSG-3035-10	35	19.8	1.5	1°	85.9	56	70
MSG-4040-10	40	24.8	1.5	1°	85.9	66	78
MSG-4042-10	42	26.8	1.5	1°	85.9	70	82
SKG-*050R-10	50	34.8	1.5	1°	85.9	86	98
SKG-5052R-10	52	36.8	1.5	1°	85.9	90	102
SKG-*063R-10	63	47.8	1.5	0°45'	114.6	112	124
SKG-6066R-10	66	50.8	1.5	0°45'	114.6	118	130
SKG-6080R-10	80	64.8	1.5	0°30'	171.9	146	158
SKG-4050R-14	50	28.4	2.5	1°	143.2	80	98
SKG-4052R-14	52	30.4	2.5	1°	143.2	84	102
SKG-*063R-14	63	41.4	2.5	0°45'	191	106	124
SKG-5066R-14	66	44.4	2.5	0°45'	191	112	130
SKG-5080R-14	80	58.4	2.5	0°30'	286.5	140	158
SKG-6100R-14	100	78.4	2.5	0°20'	430	180	198
SKG-6125R-14	125	103.4	2.5	0°20'	430	230	248
SKG-7160R-14	160	138.4	2.5	0°15'	573	300	318

Recommended Data for Profile Milling

Ramping

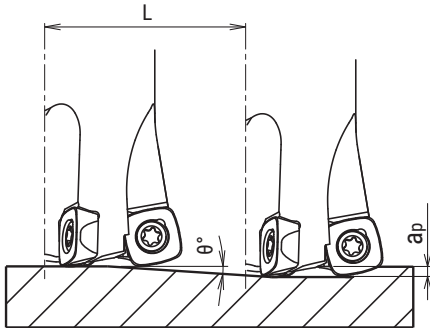

Helical interpolation

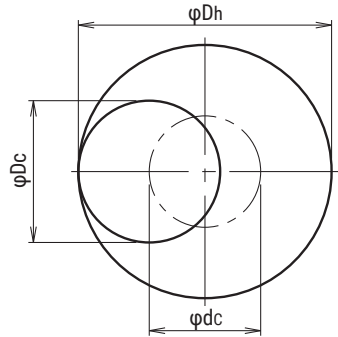

- Calculation of tool pass dia.

$$\varphi d_c = \varphi D_h - \varphi D_c$$

Tool pass dia. Bore dia. Tool Dia.

- Depth of cut per one circuit should not exceed max. depth of cut A_p
- Down cutting is recommended, tool pass rotation should be counterclockwise

- In case of ramping and helical interpolation, apply 70% or less feed (V_f) from standard cutting condition table.

- SPE (M) T100415ZPER-SM, SPMT100415ZPTR-PM

- SPMT140520ZPER-SM, SPMT140520ZPTR-PM

Cat.No.	Tool dia. (mm)	Effective Cutting dia. (mm)	Max. depth of cut : a_p (mm)	Ramping		Helical interpolation	
				Max. ramping angle θ	Total cutting length at Max. (a_p) : L (mm)	Min. Bore dia. D_h min. (mm)	Max. Bore dia. D_h max. (mm)
MSG-2025-10	25	10	1.0	1°	57.3	36	48
MSG-3032-10	32	17	1.0	1°	57.3	50	62
MSG-3035-10	35	20	1.0	1°	57.3	56	70
MSG-4040-10	40	25	1.0	1°	57.3	66	78
MSG-4042-10	42	27	1.0	1°	57.3	70	82
SKG-*050R-10	50	35	1.0	1°	57.3	86	98
SKG-5052R-10	52	37	1.0	1°	57.3	90	102
SKG-*063R-10	63	48	1.0	0°45'	76.4	112	124
SKG-6066R-10	66	51	1.0	0°45'	76.4	118	130
SKG-6080R-10	80	65	1.0	0°30'	114.6	146	158
SKG-4050R-14	50	28.8	1.8	1°	103.1	80	98
SKG-4052R-14	52	30.8	1.8	1°	103.1	84	102
SKG-*063R-14	63	41.8	1.8	0°45'	137.5	106	124
SKG-5066R-14	66	44.8	1.8	0°45'	137.5	112	130
SKG-5080R-14	80	58.8	1.8	0°30'	206.3	140	158
SKG-6100R-14	100	78.8	1.8	0°20'	206.3	180	198
SKG-6125R-14	125	123.8	1.8	0°20'	206.3	230	248
SKG-7160R-14	160	138.8	1.8	0°15'	412.5	300	318

■ Recommended Cutting Conditions - SKSG2-10 type -

Material	Insert	Grade	Vc	fz	ap	ae
Carbon Steel below 250HB	SPNW SPMT-PM	JC8050 (JC8118)	130 - 160 - 180	1.4 - 1.5 - 1.8	0.5 - 1.0 - 1.5	0.7 Dc
Tool & Die Steel below 255HB	SPNW SPMT-PM	JC8050 (JC8118)	130 - 160 - 180	1.4 - 1.5 - 1.8	0.5 - 1.0 - 1.5	0.7 Dc
Mold Steel 30-36HRC	SPNW SPMT-PM	JC8050 (JC8118)	130 - 160 - 180	1.4 - 1.5 - 1.8	0.5 - 1.0 - 1.5	0.7 Dc
Mold Steel 38-43HRC	SPNW SPMT-PM	JC8118 (JC8050)	80 - 110	1.2 - 1.3 - 1.5	0.5 - 1.0 - 1.2	0.6 Dc
Hardened Die Steel 42-52HRC	SPNW	JC8118	100	1.0 - 1.2 - 1.4	0.3 - 0.6 - 1.0	0.5 Dc
Grey & Nodular Cast Iron	SPNW SPMT-PM	JC8118	160 - 180	1.5 - 1.8	0.5 - 1.2 - 1.5	0.7 Dc
Stainless Steel	SPMT-SM SPET-SM	JC7550	100 - 130 - 150	0.9 - 1.0 - 1.4	0.5 - 1.0	0.6 Dc
Titanium Alloy	SPMT-SM SPET-SM	DS150	60	0.4 - 0.6	0.4 - 1.0	0.6 Dc

Note

1. Please adjust cutting conditions according to machine rigidity or work rigidity. (the above table is guide for cutting on a BT50 machine.)
 2. In case of chatter occurring, recommended to reduce ap or rpm and keep feed per tooth.
 3. ap should be reduced when using on low rigidity machine.
 4. Use air blow.
- ★ap ≤1.0 when using SPMT/SPET insert.

■ Recommended Cutting Conditions - SKSG2-14 type -

Material	Insert	Grade	Vc	fz	ap	ae
Carbon Steel below 250HB	SPNW SPMT-PM	JC8050 (JC8118)	100 - 150	1.4 - 1.8	0.6 - 2.0	0.7 Dc
Tool & Die Steel below 255HB	SPNW SPMT-PM	JC8050 (JC8118)	100 - 150	1.4 - 1.8	0.6 - 2.0	0.7 Dc
Mold Steel 30-36HRC	SPNW SPMT-PM	JC8050 (JC8118)	100 - 150	1.4 - 1.8	0.6 - 2.0	0.7 Dc
Mold Steel 38-43HRC	SPNW SPMT-PM	JC8118 (JC8050)	80 - 100	1.4 - 1.5	0.7 - 1.6	0.6 Dc
Hardened Die Steel 42-52HRC	SPNW	JC8118	70 - 90	0.7 - 1.2	0.5 - 1.0	0.5 Dc
Grey & Nodular Cast Iron	SPNW SPMT-PM	JC8118	160 - 180	1.4 - 1.8	0.6 - 2.0	0.7 Dc
Stainless Steel	SPMT-SM	JC7550	100 - 150	1.0 - 1.3	0.7 - 1.5	0.6 Dc
Titanium Alloy	SPMT-SM	DS150	60	0.4 - 0.6	0.7 - 1.3	0.6 Dc

Note

1. Please adjust cutting conditions according to machine rigidity or work rigidity. (the above table is guide for cutting on a BT50 machine.)
 2. In case of chatter occurring, recommended to reduce ap or rpm and keep feed per tooth.
 3. ap should be reduced when using on low rigidity machine.
 4. Use air blow.
- ★ap ≤1.8 when using SPMT insert.

SKS-GII 09

SKG09/MSG09 Type



Specifically designed for high efficiency machining of difficult to cut materials

Feature 1

Multi-edge design enables high efficiency machining. Achieved Max $ap=0.9$ mm even if difficult-to-cut materials such as titanium alloy, stainless steel & heat-resistant alloy

● Tool dia. $\varnothing 50$

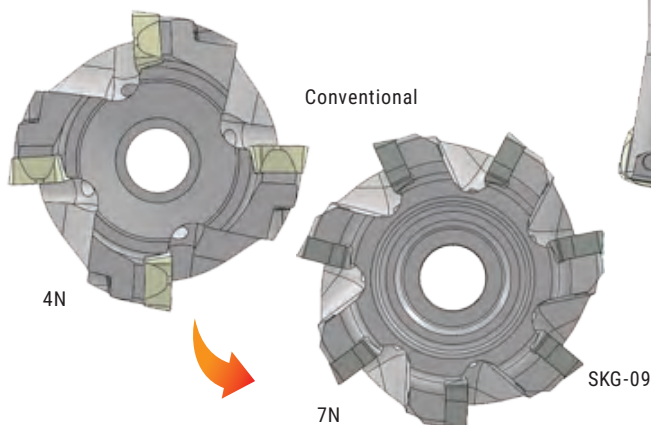

Feature 2

The optimised cutting edge design provides the sharpness and low cutting resistance that is ideal for difficult-to-cut materials.



SKS-GII 09

SKG09/MSG09 Type

Feature 3

Economical 4 cutting edges
Precise ground insert provides run out accuracy and longer tool life.

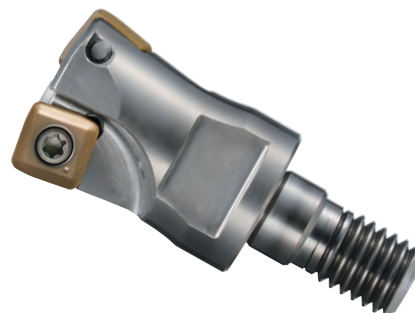

● Line up

Wear resistance

Fracture resistance

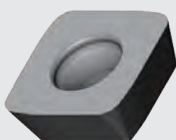

SDEW090312ZER (JC7518/DS118)

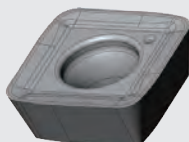

SDET090312ZDER-SM (DS118)

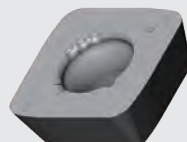

SDEW090312ZER (JC7550/DS150)



SDET090312ZDER-SM (JC7550/DS150)

Insert	Titanium alloy	Inconel	SUS630	SUS316
SDEW090312ZER (JC7518)		■	◎	
SDEW090312ZER (JC7550)			●	◎
SDEW090312ZER (DS118)	◎			
SDEW090312ZER (DS150)	●			
SDET090312ZDER-SM (JC7550)		●	●	●
SDET090312ZDER-SM (DS150)	●			
SDET090312ZDER-SM (DS118)	●			

◎: stable machining ●: unstable machining ■: light load machining

SKS-GII 09

SKG09/MSG09 Type

SKG09
TYPE

Bore Type

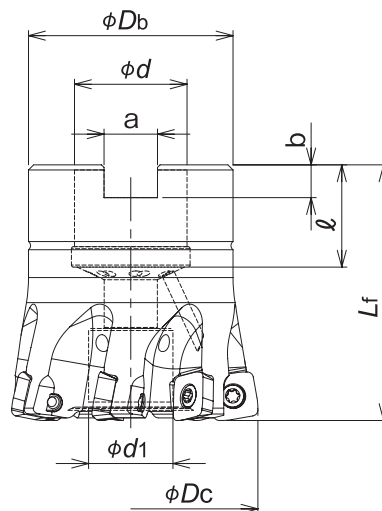

Cat.No.	Stock	No. of inserts	Dimensions (mm)								Arbor set bolt	Weight (kg)	Insert
			φDc	Lf	φDb	φd	φd1	a	b	ℓ			
SKG-5040R-09-16	●	5	40	40	37	16	13.5	8.4	5.6	18	M8	0.21	SDEW090312ZER SDET090312ZDER-SM
SKG-7050R-09-22	●	7	50	50	40	22	16.5	10.4	6.3	20	M10	0.35	
SKG-7052R-09-22	●		52		M10						0.37		
SKG-8063R-09-22	●	8	63	48	17	20	12.4	7	22	M10	0.58		
SKG-8066R-09-27	●		66	50	27					M12X1.75X30★	0.60		
SKG-9080R-09-27	●	9	80	60	20	M12X1.75X30★	0.97						

Screw	Torque(N.m)	Wrench
DSW-307H	2.1	A-10



SKG09
TYPE

Shank Type

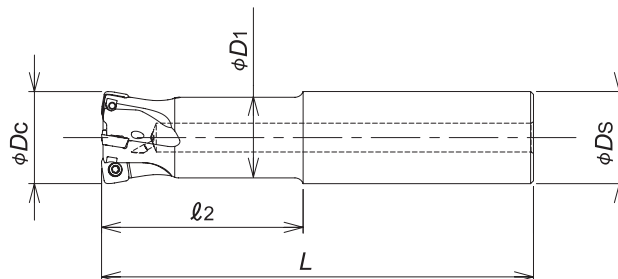

Cat.No.	Stock	No. of inserts	Dimensions (mm)					Insert
			ϕDc	$l2$	L	$\phi D1$	ϕDs	
SKG-3025-60-09-S25	○	3	25	60	140	23	25	SDEW090312ZER SDET090312ZDER-SM
SKG-3025-100-09-S25	○			100	180			
SKG-4032-70-09-S32	○	4	32	70	150	28	32	
SKG-4032-120-09-S32	○			120	200			
SKG-5035-70-09-S32	○	5	35	70	150	31	32	
SKG-5035-120-09-S32	○			120	200			

Screw	Torque(N.m)	Wrench
DSW-307H	2.1	A-10

SKS-GII 09

SKG09/MSG09 Type

MSG09
TYPE

Modular Type

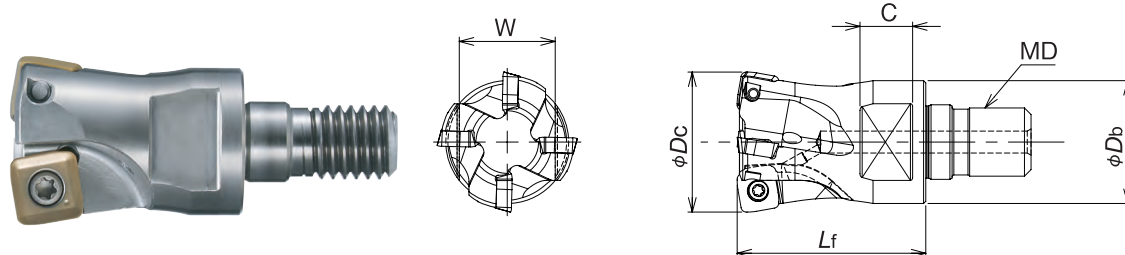

Cat.No.	Stock	No. of inserts	Dimensions (mm)						Insert	Parts		
			ϕD_c	L_f	ϕD_b	MD	C	W				
MSG-2020-09-M10	●	2	20	30	19	M10	9	14	SDEW090312ZER SDET090312ZDER-SM	DSW-306H		
MSG-2022-09-M10	○		22			M10				DSW-307H		
MSG-3025-09-M12	●	3	25	35	23	11	19	SDEW090312ZER SDET090312ZDER-SM		DSW-307H		
MSG-4028-09-M12	○	4	28		23.6						M12	
MSG-4032-09-M16	●	5	32	43	28	12	22				SDEW090312ZER SDET090312ZDER-SM	DSW-307H
MSG-5035-09-M16	●		35		M16							
MSG-5040-09-M16	●		40		M16	14	26					
MSG-5042-09-M16	●		42		M16							

Screw	Torque(N.m)	Wrench
DSW-306H	1.8	A-10
DSW-307H	2.1	A-10

SKG/MSG09
TYPE

Insert

Fig. 1



Fig. 1

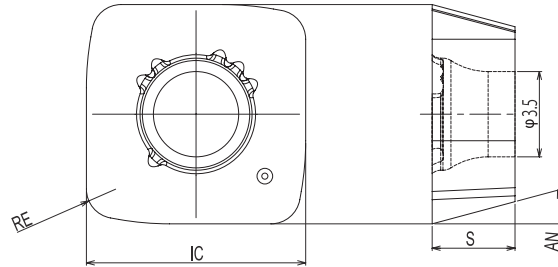
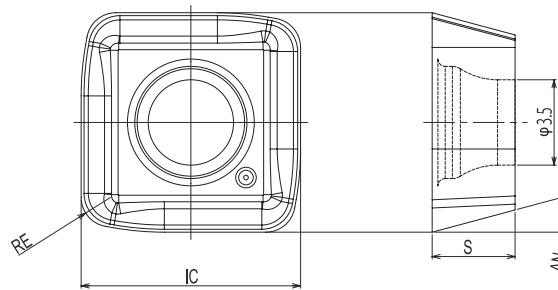

Fig. 2

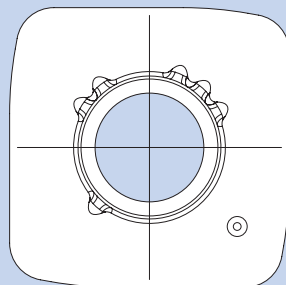

Fig. 2



Cat.No.	Tolerance	PVD Coating				Dimensions (mm)				Fig.
		DS118	DS150	JC7518	JC7550	RE	IC	S	AN	
SDEW090312ZER	E	●	●	●	●	1.2	9	3.4	15°	1
SDET090312ZDER-SM		●	●		●					2

GRADE MARKING



JC7550/DS150

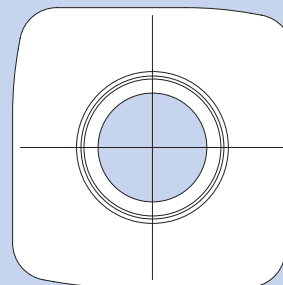

JC7518/DS118

SKS-GII 09

SKG09/MSG09 Type

■ Definition of corner shape for programming

■ SDET090312ZDER-SM
SDEW090312ZER

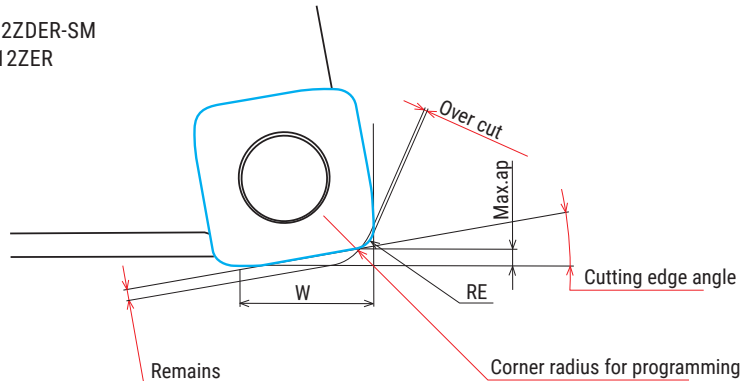

Corner radius for programming	Remains	Over cut	Max.ap	W	Cutting edge angle
1.5	0.81	0	0.9	7.1	10°
2 (Standard)	0.73	0			
2.5	0.65	0.08			

■ Recommended Data for Profile Milling

Ramping

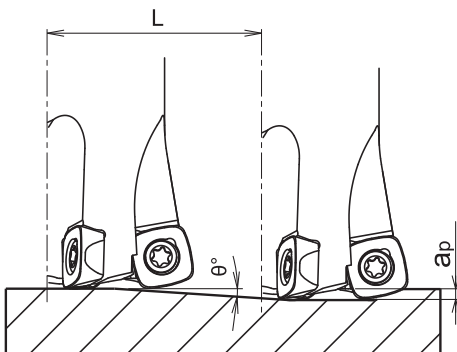

Helical interpolation

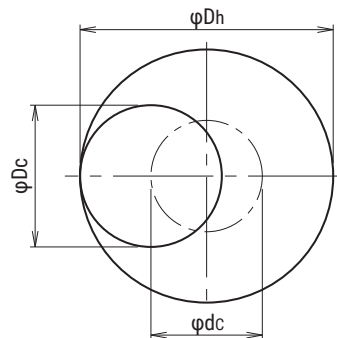

- Calculation of tool pass dia.

$$\varphi_{dc} = \varphi_{Dh} - \varphi_{Dc}$$

Tool pass dia. Bore dia. Tool dia.

- Depth of cut per one circuit should not exceed max. depth of cut Ap
- Down cutting is recommended, tool pass rotation should be counterclockwise

- In case of ramping and helical interpolation, apply 70% or less feed (Vf) from standard cutting condition table

Cat.No.	Tool dia.	Effective cutting dia.	Max.depth of cut : ap	Ramping		Helical interpolation	
				Max.ramping angle θ	Total cutting length at Max.ap : L(mm)	Min.Bore dia. (mm)	Max.Bore dia. (mm)
MSG-2020-09-M10	20	5.6	0.9	1°	51.6	27	38
MSG-2022-09-M10	22	7.7	0.9	1°	51.6	31	42
MSG-3025-09-M12	25	10.7	0.9	1°	51.6	37	48
MSG-4028-09-M12	28	13.7	0.9	1°	51.6	43	54
MSG-4032-09-M16	32	17.6	0.9	1°	51.6	51	62
MSG-5035-09-M16	35	20.6	0.9	1°	51.6	57	68
MSG-5040-09-M16	40	25.7	0.9	1°	51.6	67	78
MSG-5042-09-M16	42	27.7	0.9	1°	51.6	71	82
SKG-3025-60-09-S25	25	10.7	0.9	1°	51.6	37	48
SKG-3025-100-09-S25	25	10.7	0.9	1°	51.6	37	48
SKG-4032-70-09-S32	32	17.6	0.9	1°	51.6	51	62
SKG-4032-120-09-S32	32	17.6	0.9	1°	51.6	51	62
SKG-5035-70-09-S32	35	20.6	0.9	1°	51.6	57	68
SKG-5035-120-09-S32	35	20.6	0.9	1°	51.6	57	68
SKG-5040R-09-16	40	25.7	0.9	1°	51.6	67	78
SKG-7050R-09-22	50	35.6	0.9	1°	51.6	87	98
SKG-7052R-09-22	52	37.6	0.9	1°	51.6	91	102
SKG-8063R-09-22	63	48.7	0.9	0°45'	68.8	113	124
SKG-8066R-09-27	66	51.7	0.9	0°45'	68.8	119	130
SKG-9080R-09-27	80	65.7	0.9	0°30'	103.1	147	158

■ Recommended Cutting Conditions - SKSG2-09 type -

Material	Insert	Grade	Vc	fz	ap	ae
Austenitic Stainless Steel	SDEW (SDET)	JC7550	125 - 150	0.8 - 1.0	0.3 - 0.8	0.6 Dc
Martensitic Stainless Steel	SDEW	JC7550	155 - 190	0.8 - 1.0	0.3 - 0.8	0.6 Dc
Duplex Stainless Steel	SDEW	JC7518 (JC7550)	85 - 100	0.25 - 0.3	0.3 - 0.8	0.4~0.6 Dc
Titanium Alloy	SDEW	DS150 (DS118)	60	0.5 - 0.6	0.3 - 0.8	0.6 Dc
Heat Resistant Alloy	SDEW	JC7518 (JC7550)	25 - 30	0.5 - 0.6	0.2 - 0.5	0.4~0.6 Dc

Note

1. Please adjust cutting conditions according to machine rigidity or work rigidity. (the above table is guide for cutting on a BT50 machine.)
2. In case of chatter occurring, recommended to reduce ap or rpm and keep feed per tooth.
3. ap should be reduced when using on low rigidity machine.
4. Use air blow.
5. Wet cutting is recommended for machining Super Duplex, Titanium Alloy, Heat Resistant Alloy.

SKS EXTREME

High-feed milling tools with double side inserts which achieve ultimate high-feed machining

Feature 1

Economical double-side insert (with 6 cutting edges)



Feature 2

Due to dovetail-shaped binding face, movement of inserts which occur by cutting force is prevented only single screw clamping

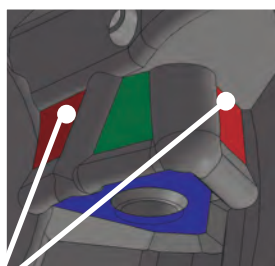

Dovetail-shaped

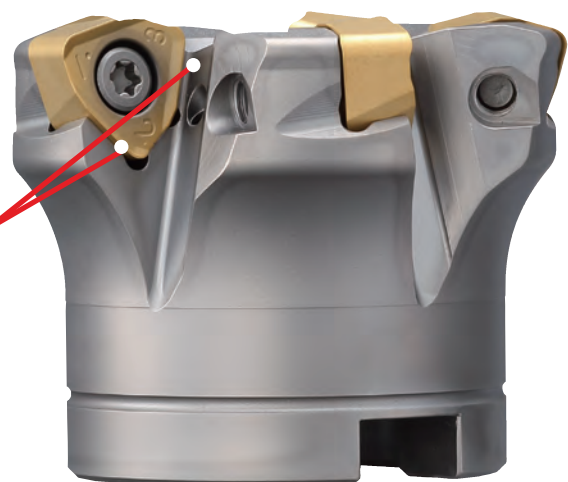

Feature 3

Application

ISO	P					M					K				H		
	P01	P10	P20	P30	P40	M01	M10	M20	M30	M40	K01	K10	K20	K30	H01	H10	H20
Applicable range			JC8050					JC8050									
		JC8118										JC8118				JC8118	
			JC7560						JC7560								

Adopted 3 insert grades:

PVD coated grade "JC7560" improved fracture toughness & heat impact resistance.

PVD coated grade "JC8118" achieved longer tool life for mold steel, high hardened die steel less than 50HRC & cast iron.

PVD coated grade "JC8050", that adopted carbide substrate with improved fracture toughness & coating layer can be widely applied for carbon steel, mold steel, & stainless steel.

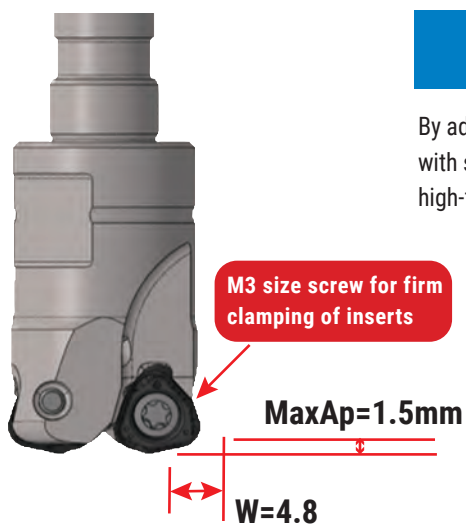

EXSKS-05 type

By adopting multi blade specification with small diameter, high-feed machining is possible.

WNMU050320ZER-PM

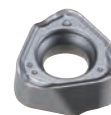

grade : JC8050
JC8118

Optimal breaker for mold steel & High hardened steel less than 50HRC

Coner radius for programming	Remains	Over cut
R2	0.59	0
R2.5	0.5	0
R3	0.41	0.13

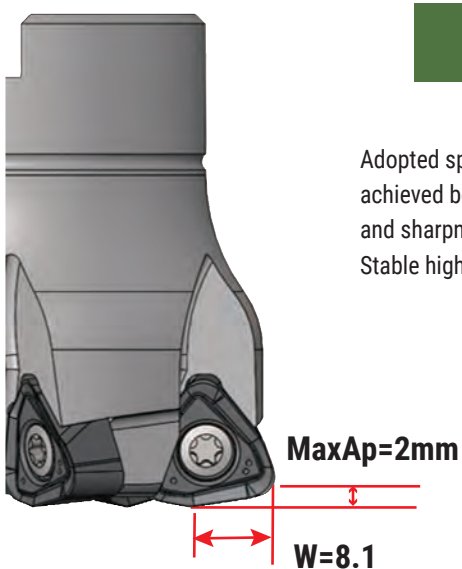

EXSKS-07type

Adopted specifications which achieved both insert strength and sharpness.
Stable high-feed machining is possible.

WNMU070620ZER-PM



grade : JC8050
JC8118

Optimal breaker for mold steel & High hardened steel less than 50HRC

Coner radius for programming	Remains	Over cut
R3	0.80	0
R3.5	0.73	0.06
R4	0.66	0.21

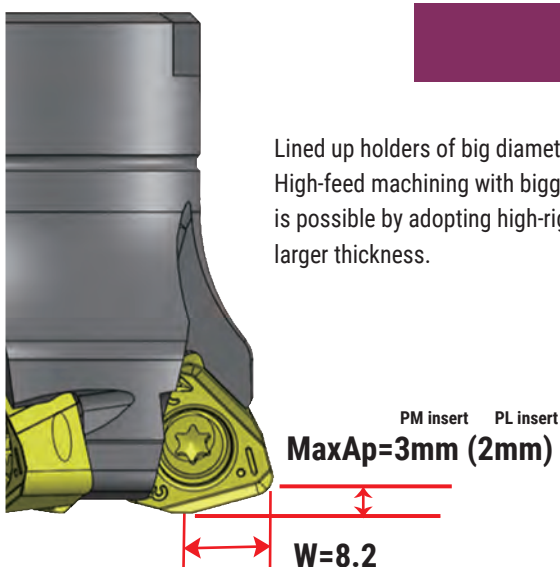

EXSKS-09type

Lined up holders of big diameter.
High-feed machining with bigger depth of cut is possible by adopting high-rigid inserts with larger thickness.

WNMU090828ZER-PL

grade: JC8050 / JC8118

Suitable for machining shapes such as pocket milling with ap = 0.6 mm to ap = 1.2 mm.

The composite shape of the straight and radius cutting edges reduces fluctuations in cutting resistance during corner machining, realizing stable machining and extending tool life.



WNMU090720ZER-PM

grade : JC8050/JC8118/JC7560

Suitable for face milling of ap=1.4mm or more and shape machining such as pocket machining.



Coner radius for programming	Remains	Over cut
R3	1.41	0
R3.5	1.3	0
R4	1.19	0.025

SKS EXTREME **EXSKS/MEX Type**

EXSKS-05
TYPE

Bore Type

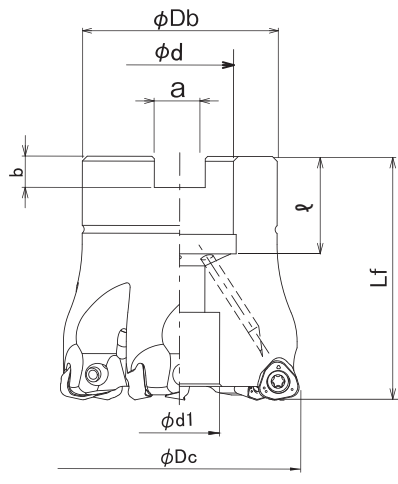

Cat.No.	Stock	No. of inserts	Dimensions (mm)								Arbor set bolt	Weight (kg)	Insert
			phi Dc	Lf	phi Db	phi d	phi d1	a	b	l			
EXSKS-5040R-05-16	●	5	40	45	35	16	13.5	8.4	5.8	19	M8	0.25	WNMU050320ZER-PM
EXSKS-7050R-05-22	●	7	50	50	40	22	16.5	10.4	6.3	20	M10	0.39	
EXSKS-7052R-05-22	●	7	52	50	40	22	16.5	10.4	6.3	20	M10	0.41	
EXSKS-8063R-05-22	○	8	63	50	48	22	17	10.4	6.3	20	M10	0.65	

MEX-05
TYPE

Modular Type

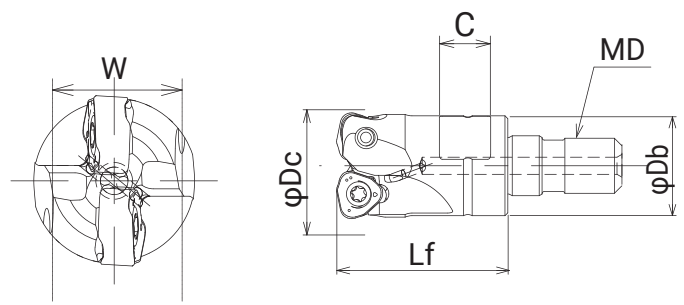

Cat.No.	Stock	No. of inserts	Dimensions (mm)						Insert
			phi Dc	Lf	phi Db	MD	C	W	
MEX-2020-05-M10	●	2	20	30	18	M10	9	14	WNMU050320ZER-PM
MEX-2021-05-M10	○	2	21	30	18	M10	9	14	
MEX-3025-05-M12	●	3	25	35	23	M12	11	19	
MEX-3026-05-M12	○	3	26	35	23	M12	11	19	
MEX-3028-05-M12	○	3	28	28	23	M12	11	19	
MEX-4030-05-M16	○	4	30	43	27	M16	12	22	
MEX-4032-05-M16	●	4	32	43	29	M16	12	22	
MEX-4033-05-M16	○	4	33	43	29	M16	12	22	
MEX-4035-05-M16	●	4	35	43	29	M16	12	22	
MEX-5040-05-M16	●	5	40	43	32	M16	14	26	

EXSKS-05 TYPE

Shank Type

Through coolant hole

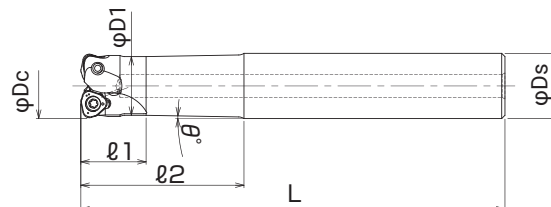

Cat.No.	Stock	No. of inserts	Dimensions (mm)							Inserts
			φDc	ℓ1	ℓ2	L	φd1	φDs	θ°	
EXSKS-2020-05-50-S20	●	2	20	20	50	130	18	20	1	WNMU050320ZER-PM
EXSKS-2020-05-80-S20	○	2	20	20	80	160	18	20	0.5	
EXSKS-2021-05-50-S20	○	2	21	20	50	130	18	20	1	
EXSKS-2021-05-80-S20	○	2	21	20	80	160	18	20	0.5	
EXSKS-3025-05-60-S25	●	3	25	25	60	140	23	25	1	
EXSKS-3025-05-100-S25	○	3	25	25	100	180	23	25	0.5	
EXSKS-3026-05-60-S25	○	3	26	25	60	140	23	25	1	
EXSKS-3026-05-100-S25	○	3	26	25	100	180	23	25	0.5	
EXSKS-4032-05-70-S32	●	4	32	30	70	150	29	32	1.5	
EXSKS-4032-05-120-S32	○	4	32	30	120	200	29	32	0.5	

Screw	Torque(N.m)	Wrench
TSW-307H	2.1	A-10

Insert

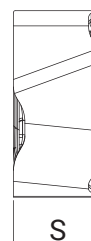
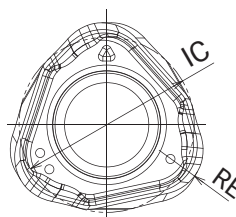

Cat.No.	Tolerance	PVD coated		Dimensions (mm)		
		JC8118	JC8050	RE	IC	S
WNMU050320ZER-PM	M	●	●	2	7.7	3.9

GRADE MARKING

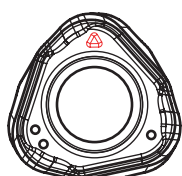

JC8050

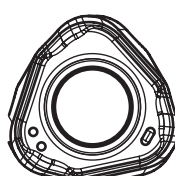

JC8118

SKS EXTREME

EXSKS/MEX Type

EXSKS-07 TYPE

Bore Type

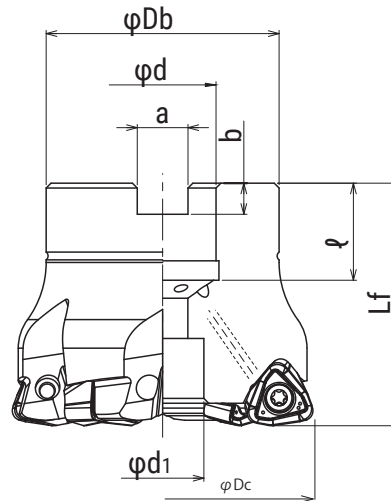

Cat.No.	Stock	No. of inserts	Dimensions (mm)								Arbor set bolt	Weight (kg)	Insert
			φDc	Lf	φDb	φd	φd1	a	b	φ			
EXSKS-5050R-07-22	●	5	50	50	40	22	16.5	10.4	6.3	20	M10	0.38	WNMU070620ZER-PM
EXSKS-5052R-07-22	●	5	52	50	40	22	16.5	10.4	6.3	20	M10	0.40	
EXSKS-6063R-07-22	●	6	63	50	48	22	17	10.4	6.3	20	M10	0.64	
EXSKS-7080R-07-27	●	7	80	55	65	27	20	12.4	7	22	M12X1.75X35★	1.23	
EXSKS-8100R-07-32	●	8	100	50	85	32	26	14.4	8	25	M16X2X25	1.76	



MEX-07 TYPE

Modular Type

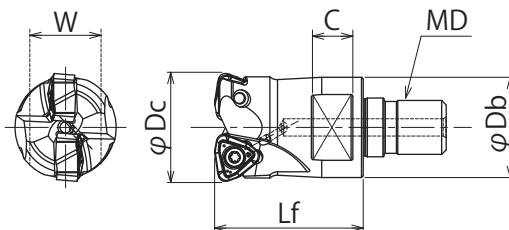

Cat.No.	Stock	No. of inserts	Dimensions (mm)						Insert
			φDc	Lf	φDb	MD	C	W	
MEX-2032-07-M16	●	2	32	43	29	M16	12	22	WNMU070620ZER-PM
MEX-3035-07-M16	●	3	35	43	29	M16	12	22	
MEX-4040-07-M16	●	4	40	43	32	M16	14	26	
MEX-4042-07-M16	●	4	42	43	32	M16	14	26	

Through coolant hole

EXSKS-07
TYPE

Shank Type

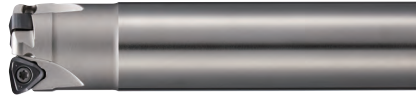

Fig.1

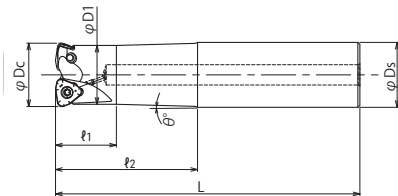
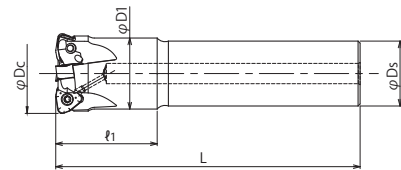

Fig.2



Cat.No.	Stock	No. of inserts	Dimensions (mm)							Fig.	Insert
			φD_c	l_1	l_2	L	φd_1	φD_s	θ°		
EXSKS-2032-07-70-S32	○	2	32	30	70	150	29	32	1.5	1	WNMU070620ZER-PM
EXSKS-2032-07-120-S32	○	2	32	30	120	200	29	32	0.6	1	
EXSKS-3035-07-40-S32	○	3	35	40	-	150	31	32	-	2	
EXSKS-3035-07-40L-S32	○	3	35	40	-	200	31	32	-	2	
EXSKS-4040-07-50-S32	○	4	40	50	-	150	35	32	-	2	
EXSKS-4040-07-50L-S32	○	4	40	50	-	200	35	32	-	2	

Screw	Torque(N.m)	Wrench
TSW-410H	3.5	A-15

Insert

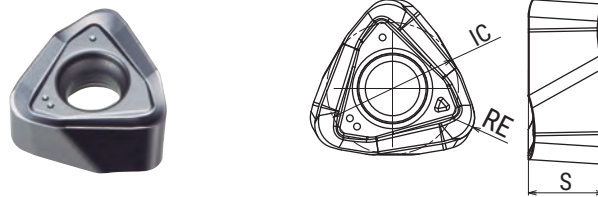

Cat.No.	Tolerance	PVD coated		Dimensions (mm)		
		JC8118	JC8050	RE	IC	S
WNMU070620ZER-PM	M	●	●	2	11.2	6.4

GRADE MARKING

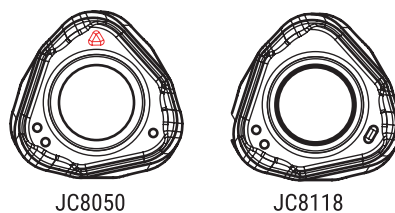

SKS EXTREME

EXSKS/MEX Type

EXSKS-09
TYPE

Bore Type

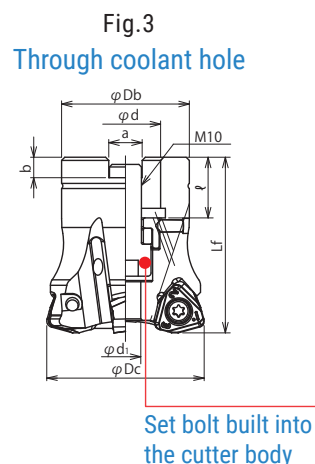
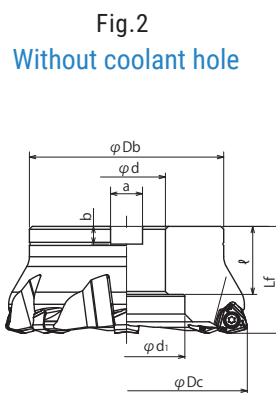
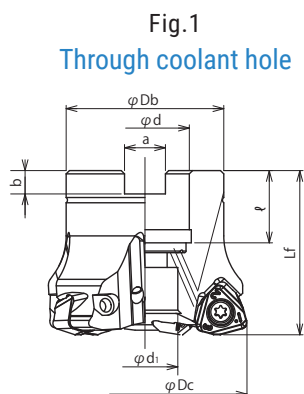

Cat.No.	Stock	No. of inserts	Dimensions (mm)								Arbor set bolt	Weight (kg)	Fig.	Inserts
			φDc	Lf	φDb	φd	φd1	a	b	ℓ				
EXSKS-3050R-22	○	3	50	55	40	22	9.6	10.4	6.3	19	M10×1.5×25	0.4	3	WNMU090720ZER-PM WNMU090828ZER-PL
EXSKS-4050R-22	●	4	50	55	40	22	9.6	10.4	6.3	19	M10×1.5×25	0.3	3	
EXSKS-4052R-22	●	4	52	50	40	22	17	10.4	6.3	20	M10	0.4	1	
EXSKS-4063R-22	○	4	63	50	48	22	17	10.4	6.3	20	M10	0.5	1	
EXSKS-5063R-22	●	5	63	50	48	22	17	10.4	6.3	20	M10	0.5	1	
EXSKS-5063R-27	●	5	63	50	48	27	20	12.4	7	22	M12×1.75×30	0.5	1	
EXSKS-5066R-27	●	5	66	50	48	27	20	12.4	7	22	M12×1.75×30	0.5	1	
EXSKS-6080R-27	●	6	80	55	65	27	37	12.4	7	22	M12×1.75×40	0.9	1	
EXSKS-7100R-32	●	7	100	70	85	32	26	14.4	8	32	M16×2×45	1.9	1	
EXSKS-8125R-40	●	8	125	70	100	40	32	16.4	9	35	M20×2.5×45	3.9	1	
EXSKS-9160R-40	●	9	160	55	100	40	85	16.4	9	35	M20	3.9	2	

Screw	Torque(N.m)	Wrench
CSW-513H	5.5	A-20

SKS EXTREME **EXSKS/MEX Type**

Insert

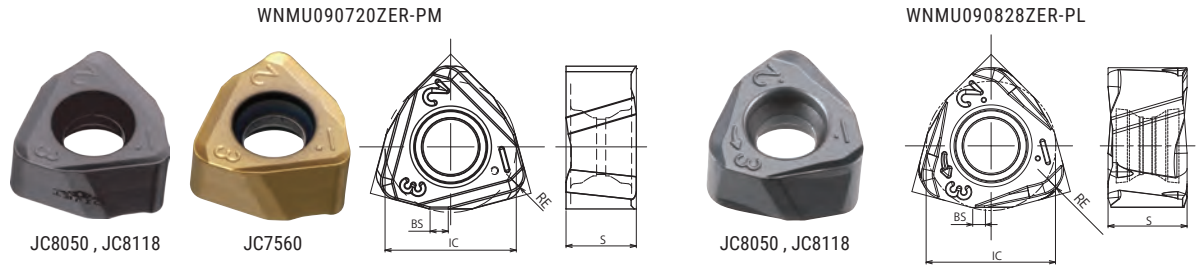

Cat.No.	Tolerance	PVD coated			Dimensions (mm)			
		JC8118	JC8050	JC7560	IC	S	BS	RE
WNMU090720ZER-PM	M	●	●	●	14	7.66	1.94	2
WNMU090828ZER-PL	M	●	●		13.91	8.66	1.37	2.8

Note: When using PL inserts, tool dia. will be smaller than PM insert.
 In case dia. $\phi 100$ holder, tool dia. is 0.06mm smaller.
 In case dia. $\phi 125$ holder, tool dia. is 0.11mm smaller.
 In case dia. $\phi 160$ holder, tool dia. is 0.15mm smaller

GRADE MARKING

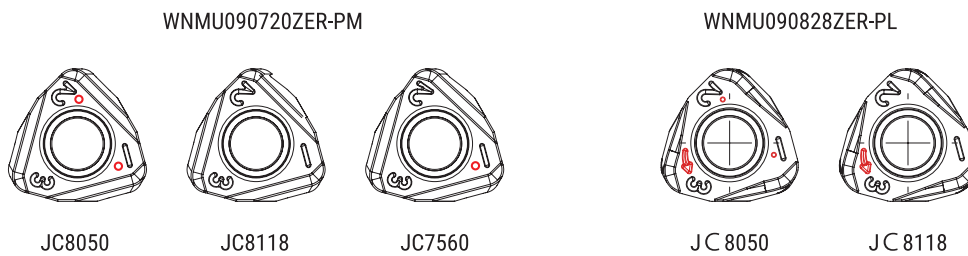

SKS EXTREME

EXSKS/MEX Type

EXSKS-05 TYPE

Definition of corner shape for programming

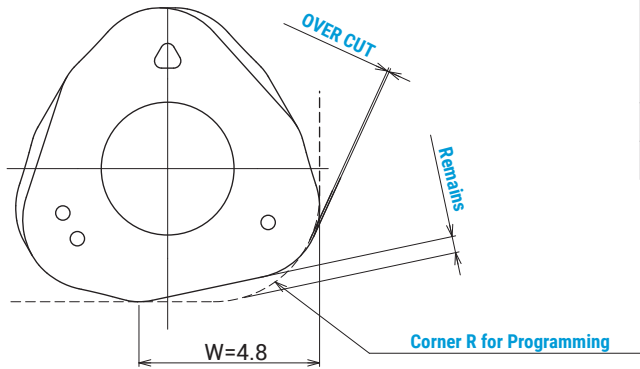

Corner radius for programming	Remains	Over cut
R2.0	0.59	0
R2.5 (Std.)	0.5	0
R3.0	0.41	0.13

(mm)

Attention for profile milling

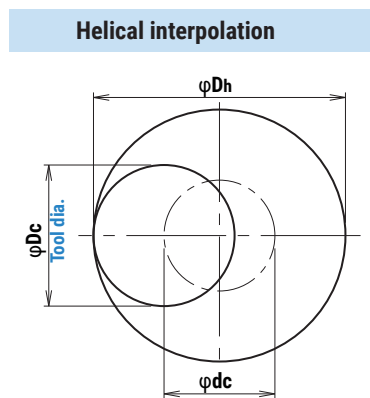
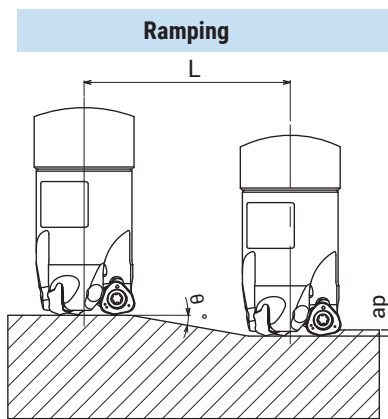

● Calculation of tool pass dia.

$$\varphi Dc = \varphi Dh - \varphi Dc$$

Tool pass dia. Bore dia. Tool dia.

- Depth of cut per one circuit should not exceed max. depth of cut ap.
- Down cutting is recommended, so tool pass rotation should be counterclockwise.
- To obtain a flat bottom surface when helical milling, it requires to remove "the uncut part" in the center of the work material at a final pass.

- In case of ramping and helical interpolation, apply 70% or less feed speed from standard cutting condition table.
- In case of drilling, apply 50% or less Z axis feed speed from standard cutting condition table.
- Long consecutive chips may come out in case of drilling, confirm the safe condition sufficiently.

Cat. No.	Tool dia. (mm)	EFF. Cutting dia. (mm)	Max. depth of cut (mm) ap	Ramping		Helical interpolation			Max. drilling depth Z (mm)
				Max. ramping angle θ°	Total cutting length at Max ap	Min. bore dia. Dh min (mm)	Max. bore dia. Dh min (mm)	Dh min (mm)	
EXSKS-*020/MEX-*020	20	10	1.5	2.8	31	28	36	31	0.4
EXSKS-*021/MEX-*021	21	11	1.5	2.6	34	30	38	33	0.4
EXSKS-*025/MEX-*025	25	15	1.5	1.8	48	38	46	41	0.4
EXSKS-*026/MEX-*026	26	16	1.5	1.7	51	40	48	43	0.4
MEX-*028	28	18	1.5	1.5	58	44	52	47	0.4
MEX-*030	30	20	1.5	1.3	67	48	56	51	0.4
EXSKS-*032/MEX-*032	32	22	1.5	1.2	72	52	60	55	0.4
MEX-*033	33	23	1.5	1.1	79	54	62	57	0.4
MEX-*035	35	25	1.5	1	86	58	66	61	0.4
EXSKS-*040/MEX-*040	40	30	1.5	0.8	108	68	76	71	0.4
EXSKS-*050	50	40	1.5	0.6	144	88	96	91	0.4
EXSKS-*052	52	42	1.5	0.6	144	92	100	95	0.4
EXSKS-*063	63	53	1.5	0.5	172	114	122	117	0.4

SKS EXTREME **EXSKS/MEX Type**

EXSKS-07
TYPE **Definition of corner shape for programming**

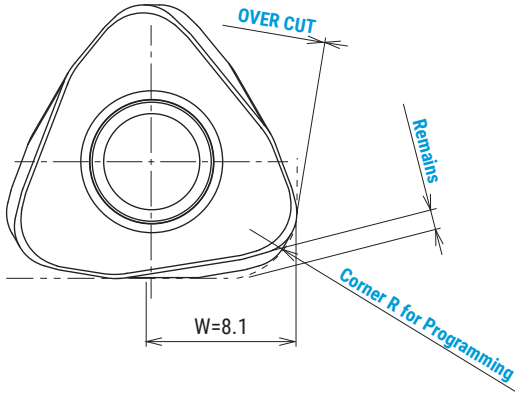

Corner radius for programming	Remains	Over cut
R3.0 (Std.)	0.8	0
R3.5	0.73	0.06
R4.0	0.66	0.21

(mm)

Attention for profile milling

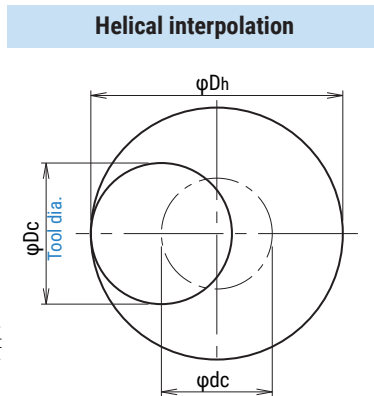
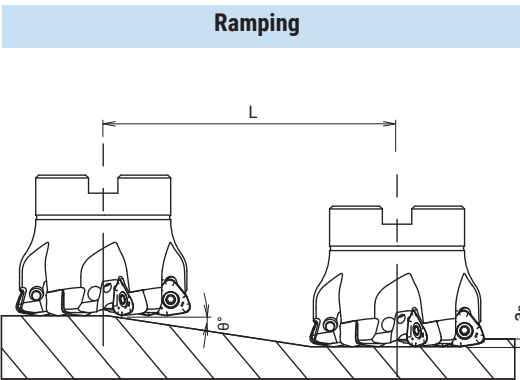

● Calculation of tool pass dia.

$$\varphi Dc = \varphi Dh - \varphi Dc$$

Tool pass dia. Bore dia. Tool dia.

- Depth of cut per one circuit should not exceed max. depth of cut ap.
- Down cutting is recommended, so tool pass rotation should be counterclockwise.
- To obtain a flat bottom surface when helical milling, it requires to remove "the uncut part" in the center of the work material at a final pass.

- In case of ramping and helical interpolation, apply 70% or less feed speed from standard cutting condition table.
- In case of drilling, apply 50% or less Z axis feed speed from standard cutting condition table.
- Long consecutive chips may come out in case of drilling, confirm the safe condition sufficiently.

Cat. No.	Tool dia. (mm)	EFF. Cutting dia. (mm)	Max. depth of cut (mm) ap	Ramping		Helical interpolation			Max. drilling depth Z (mm)
				Max. ramping angle θ°	Total cutting length at Max ap	Min. bore dia. Dh min (mm)	Max. bore dia. Dh min (mm)	Dh min (mm)	
EXSKS-*032/MEX-*032	32	15	2	2.2	53	41	60	48	0.5
EXSKS-*035/MEX-*035	35	18	2	2.1	55	47	66	54	0.5
EXSKS-*040/MEX-*040	40	23	2	2	58	57	76	64	0.5
MEX-*042	42	25	2	1.8	64	61	80	68	0.5
EXSKS-*050	50	33	2	1.5	77	77	96	84	0.5
EXSKS-*052	52	35	2	1.2	96	81	100	88	0.5
EXSKS-*063	63	46	2	1	115	103	122	110	0.5
EXSKS-*080	80	63	2	0.8	144	137	156	144	0.5
EXSKS-*100	100	83	2	0.5	230	178	198	183	0.6

SKS EXTREME EXSKS/MEX Type

EXSKS-09 TYPE Definition of corner shape for programming

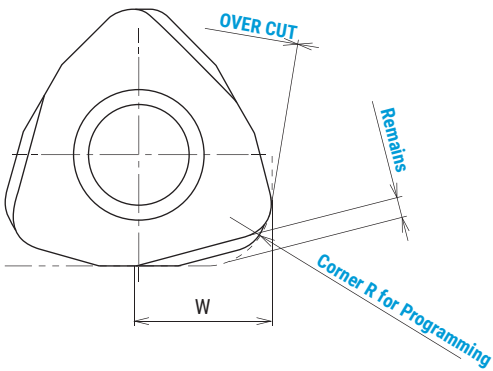

Insert	W	Corner radius for programming	Remains	Over cut
WNMU090720ZER-PM	8.2	R3.0	1.41	0
		R3.5	1.30	0
		R4.0	1.19	0.025
Insert	W	Corner radius for programming	Remains	Over cut
WNMU090828ZER-PL	8.4	R3.0	1.18	0
		R3.5	1.06	0
		R4.0	0.95	0.010

Attention for profile milling

Ramping

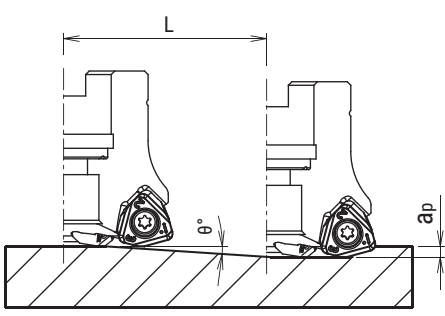

Helical interpolation

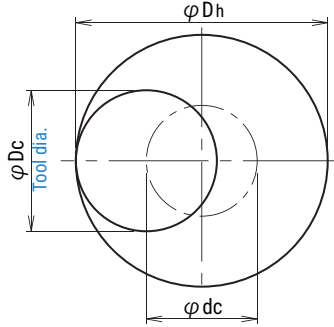

- Calculation of tool pass dia.

$$\phi_{Dc} = \phi_{Dh} - \phi_{Dc}$$
Tool pass dia. Bore dia. Tool dia.
- Depth of cut per one circuit should not exceed max. depth of cut ap.
- Down cutting is recommended, so tool pass rotation should be counterclockwise.
- To obtain a flat bottom surface when helical milling, it requires to remove "the uncut part" in the center of the work material at a final pass.

- In case of ramping and helical interpolation, apply 70% or less feed speed from standard cutting condition table.
- In case of drilling, apply 50% or less Z axis feed speed from standard cutting condition table.
- Long consecutive chips may come out in case of drilling, confirm the safe condition sufficiently.

WNMU090720ZER-PM

Cat. No.	Tool dia. (mm)	EFF. Cutting dia. (mm)	Max. depth of cut (mm) ap	Ramping		Helical interpolation			Max. drilling depth Z (mm)
				Max. ramping angle theta°	Total cutting length at Max ap	Min. bore dia. Dh min (mm)	Max. bore dia. Dh min (mm)	Dh min (mm)	
EXSKS-*050	50	33	3	2.5	69	73	96	81	1.1
EXSKS-*052	52	35	3	2.4	72	77	100	85	1.2
EXSKS-*063	63	46	3	1.8	96	99	122	107	1.2
EXSKS-*066	66	49	3	1.7	102	105	128	113	1.2
EXSKS-*080	80	63	3	1.3	133	133	156	141	1.3
EXSKS-*100	100	83	3	1	172	173	196	181	1.3
EXSKS-*125	125	108	3	0.9	191	223	246	231	1.3
EXSKS-*160	160	143	3	0.7	246	293	316	301	1.7

WNMU090828ZER-PL

Cat. No.	Tool dia. (mm)	EFF. Cutting dia. (mm)	Max. depth of cut (mm) ap	Ramping		Helical interpolation			Max. drilling depth Z (mm)
				Max. ramping angle theta°	Total cutting length at Max ap	Min. bore dia. Dh min (mm)	Max. bore dia. Dh min (mm)	Dh min (mm)	
EXSKS-*050	50	33	2	2.3	50	74	96	82	1
EXSKS-*052	52	35	2	2.2	53	78	100	86	1
EXSKS-*063	63	46	2	1.8	64	100	122	108	1.2
EXSKS-*066	66	49	2	1.7	68	106	128	114	1.2
EXSKS-*080	80	63	2	1.3	89	134	156	142	1.3
EXSKS-*100	99.94	83	2	1	115	174	195	182	1.3
EXSKS-*125	124.89	108	2	0.9	128	224	245	232	1.4
EXSKS-*160	159.85	142	2	0.7	164	294	315	302	1.6

■ Recommended Cutting Conditions - EXSKS-05 type -

Material	Grade	Vc	fz	ap	ae
Carbon Steel below 250HB	JC8050 (JC8118)	120 - 200	0.7 - 1.2	0.4 - 1.0	0.7 Dc
Tool & Die Steel below 255HB	JC8050 (JC8118)	110 - 180	0.7 - 1.2	0.4 - 1.0	0.7 Dc
Mold Steel 30-36HRC	JC8118 (JC8050)	110- 180	0.7 - 1.2	0.4 - 1.0	0.7 Dc
Mold Steel 38-43HRC	JC8118 (JC8050)	80- 130	0.7 - 1.0	0.4 - 0.8	0.6 Dc
Hardened Die Steel 42-52HRC	JC8118	70- 100	0.5 - 0.8	0.5 - 0.7	0.5 Dc
Grey Cast Iron	JC8118 (JC8050)	130 - 200	0.8 - 1.4	0.5 - 1.0	0.7 Dc
Nodular Cast Iron	JC8118 (JC8050)	110 - 180	0.7 - 1,2	0.5 - 1.0	0.7 Dc
Austenitic Stainless Steel	JC8050	90 - 150	0.7 - 1.0	0.4 - 0.8	0.5 Dc
Martensitic Stainless Steel	JC8118 (JC8050)	100 - 170	0.9 - 1.2	0.5 - 1.0	0.5 Dc

Note

1. Please adjust cutting conditions according to machine rigidity or work rigidity. (the above table is guide for cutting on a BT50 machine.)
2. In case of chatter occurring, recommended to reduce ap or rpm and keep feed per tooth.
3. ap should be reduced when using on low rigidity machine.
4. Use air blow.

■ Recommended Cutting Conditions - EXSKS-07 type -

Material	Grade	Vc	fz	ap	ae
Carbon Steel below 250HB	JC8050	120 - 200	1.1 - 1.5	0.5 - 1.5	0.7 Dc
Tool & Die Steel below 255HB	JC8050	100 - 180	1.1 - 1.5	0.5 - 1.5	0.7 Dc
Mold Steel 30-36HRC	JC8118	100 - 180	1.1 - 1.5	0.5 - 1.5	0.7 Dc
Mold Steel 38-43HRC	JC8118	80 - 130	1.0 - 1.3	0.4 - 1.2	0.6 Dc
Hardened Die Steel 42-52HRC	JC8118	70 - 100	0.8 - 1.0	0.4 - 1.0	0.5 Dc
Grey Cast Iron	JC8118	120 - 200	1.1 - 1.5	0.5 - 2.0	0.7 Dc
Nodular Cast Iron	JC8118	100 - 170	1.1 - 1.5	0.5 - 1.5	0.7 Dc
Austenitic Stainless Steel	JC8050	80 - 150	1.0 - 1.2	0.4 - 1.2	0.5 Dc
Martensitic Stainless Steel	JC8118	100 - 170	1.0 - 1.3	0.5~1.5	0.5 Dc

Note

1. Please adjust cutting conditions according to machine rigidity or work rigidity. (the above table is guide for cutting on a BT50 machine.)
2. In case of chatter occurring, recommended to reduce ap or rpm and keep feed per tooth.
3. ap should be reduced when using on low rigidity machine.
4. Use air blow.

■ Recommended Cutting Conditions - EXSKS-09 type -

Material	Grade	Vc	fz	ap	ae
Carbon Steel below 250HB	JC7560 JC8050 (JC8118)	100 - 150	1.0 - 2.0	0.4 - 2.0	0.7 Dc
Tool & Die Steel below 255HB	JC7560 JC8050 (JC8118)	100 - 150	1.0 - 2.0	0.4 - 2.0	0.7 Dc
Mold Steel 30-36HRC	JC7560 JC8050 (JC8118)	90 - 130	1.0 - 2.0	0.4 - 2.0	0.7 Dc
Mold Steel 38-43HRC	JC8118 (JC8050)	70 - 110	0.5 - 1.0	0.4 - 1.5	0.6 Dc
Hardened Die Steel 42-52HRC	JC8118	60 - 80	0.5 - 1.0	0.4 - 1.5	0.5 Dc
Grey Cast Iron	JC8118	100 - 190	1.0 - 2.0	0.4 - 2.5	0.7 Dc
Nodular Cast Iron	JC8118	100 - 190	1.0 - 2.0	0.4 - 2.5	0.7 Dc
Stainless Steel	JC8050 (JC7560)	100 - 150	1.0 - 1.5	0.4 - 2.0	0.5 Dc

Note

1. Please adjust cutting conditions according to machine rigidity or work rigidity. (the above table is guide for cutting on a BT50 machine.)
2. In case of chatter occurring, recommended to reduce ap or rpm and keep feed per tooth.
3. ap should be reduced when using on low rigidity machine.
4. Use air blow.

Achieving high metal removal rates! High efficiency machining for versatile applications



Feature 1

Optimized cutting edge for a wide range of applications

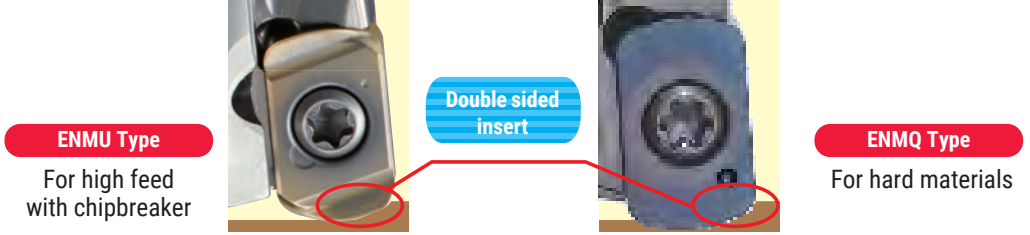

Feature 2

Economical double sided insert with 4 cutting edges for various types of materials; Carbon steel, Hardened material <upto 62HRC>, Stainless steel, Titanium alloy

● **Line up**



- | | | | |
|---|--|--|--|
| 
ENMU100412ZER-SL
• Low cutting force
• Sharp cutting edge
• Grade C7550, JC7518
DS118, DS150 | 
ENMU100412ZER-PH
• For general applications
• Grade JC8118, JC8050 , JC7560 | 
ENMU100312ZER-HL
• For hardened materials up to 60HRC
• enhanced cutting edge strength but retains sharpness
• Grade DH102 | 
ENMQ100312ZER
• Flat top insert
• Grade DH102
• For hardened materials over 60HRC |
|---|--|--|--|

● **Insert grades**

ISO	P				M				K				S				H				
	P01	P10	P20	P30	P40	M01	M10	M20	M30	M40	K01	K10	K20	K30	S01	S10	S20	S30	H01	H10	H20
Range																					
			JC8118					JC8118					DH102				DS118				
				JC8050					JC8050				JC8118				DS150				
			JC7518					JC7518						JC8050				JC8118			JC8118
				JC7550					JC7550								JC7518				
					JC7560				JC7560					JC7560			JC7550				JC7518

GMX
TYPE

Bore Type

Through coolant hole

G-Body

Face Milling

Copy Milling

Pocket Milling

Helical Interpolation

Plunge Milling

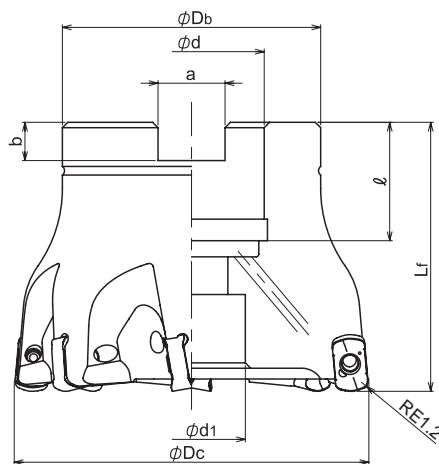

Cat.No	Stock	No. of inserts	Dimensions (mm)								Weight (kg)	Inserts					
			φDc	Lf	φDb	φd	φd1	a	b	ℓ							
GMX-7050R-22	●	7	50	50	40	22	17	10.4	6.3	20	0.35	ENMU100412ZER-** ENM*100312ZER-**					
GMX-7052R-22	●		52								0.40						
GMX-7063R-22	●		63		48						27		20	12.4	7	22	0.64
GMX-7066R-27	●		66														0.66

Screw	Torque(N.m)	Wrench
TSW-2567H	1.1	A-08

QM MAX GII

GMX/MXG Type

GMX
TYPE

Shank Type

Through coolant hole

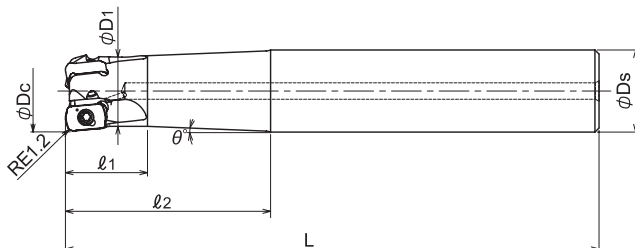

Cat.No.	Stock	No. of inserts	Dimensions (mm)						θ° taper angle	Insert
			φDc	ℓ1	ℓ2	L	φD1	φDs		
GMX-2016-30-S16	●	2	16	16	30	100	14	16	3.5°	ENMU100412ZER-** ENM*100312ZER-**
GMX-2016-50-S16	●				50				150	
GMX-3020-50-S20	●	3	20	20	130	17.2	20	2.3°		
GMX-3020-80-S20	●				80			160	1°	
GMX-4025-60-S25	●	4	25	25	60	140	22	25	2°	
GMX-4025-100-S25	●				100				180	
GMX-5032-70-S32	●	5	32	30	70	150	29	32	1.5°	
GMX-5032-120-S32	●				120				200	

Screw	Torque(N.m)	Wrench
TSW-2567H	1.1	A-08

MXG
TYPE

Modular Type

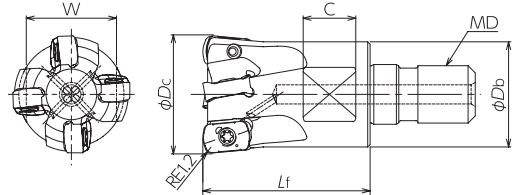

Cat.No.	Stock	No. of inserts	Dimensions (mm)						Insert
			φDc	Lf	φDb	MD	C	W	
MXG-2016-M8	●	2	16	23	14	M8	8	12	ENMU100412ZER-** ENM*100312ZER-**
MXG-2017-M8	●		17						
MXG-3020-M10	●	3	20	30	18	M10	9	14	
MXG-3021-M10	●		21						
MXG-3022-M10	○		22						
MXG-3025-M12	●	4	25	35	22	M12	11	19	
MXG-4025-M12	●		26						
MXG-4026-M12	●		28						
MXG-4028-M12	○		28						
MXG-5030-M16	●	5	30	43	27	M16	12	22	
MXG-5032-M16	●		32						
MXG-5035-M16	●		35						
MXG-6040-M16	●	6	40	43	29	M16	12	22	
MXG-6042-M16	●		42						

Screw	Torque(N.m)	Wrench
TSW-2567H	1.1	A-08

QM MAX GII

GMX/MXG Type

GMX/MXG TYPE

Insert

ENMU100412ZER-PH

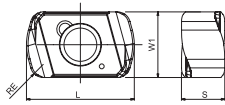

ENMU100412ZER-SL

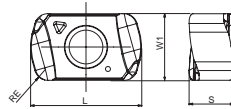

ENMU100312ZER-HL

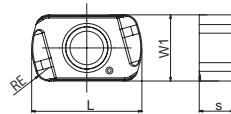

ENMQ100312ZER

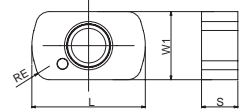

Cat.No.	Tolerance	PVD Coating							Dimensions (mm)				
		DH102	JC7518	JC7550	JC7560	JC8050	JC8118	DS118	DS150	RE	L	W1	S
ENMU100412ZER-PH	M				●	●	●			1.2	10	6	4
ENMU100412ZER-SL			●	●				●	●				
ENMU100312ZER-HL		●											
ENMQ100312ZER		●											3.2

GRADE MARKING

ENMU100412ZER-PH

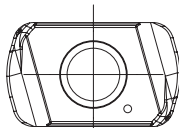

JC8118

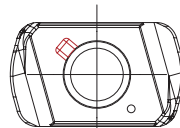

JC8050

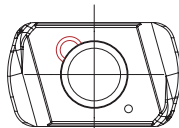

JC7560

ENMU100412ZER-SL

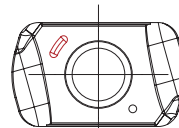

JC7518/DS118

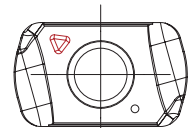

JC7550/DS150

■ Insert selection guide

Materials	Grade	Cat.No.			
		ENMU100412ZER-PH For general milling	ENMU100412ZER-SL Low cutting force	ENMU100312ZER-HL For Hardened materials	ENMQ100312ZER Flat top insert
Chip breaker					
Carbon steel (S50C, S55C) below 250HB	JC8118	○			
	JC8050	◎			
	JC7560	●			
	JC7550				
	JC7518		☆		
	DH102				
	DS118				
	DS150				
Tool & die steel (SKD61, SKD11) below 255HB	JC8118	○			
	JC8050	◎			
	JC7560	●			
	JC7550				
	JC7518		☆		
	DH102				
	DS118				
	DS150				
Mold steel (HPM7, PX5, P20) 30 - 36HRC	JC8118	○			
	JC8050	◎			
	JC7560	●			
	JC7550				
	JC7518		☆		
	DH102				
	DS118				
	DS150				
Mold steel (NAK80, HPM1, P21) 38 - 43HRC	JC8118	◎			
	JC8050	●			
	JC7560				
	JC7550				
	JC7518		☆		
	DH102				
	DS118				
	DS150				
Hardened die steel (SKD61, DAC, DHA) 42 - 52HRC	JC8118	◎			
	JC8050				
	JC7560				
	JC7550				
	JC7518		☆		
	DH102			●	
	DS118				
	DS150				
Hardened die steel (SKD11, SLD, DC11) 55 - 62HRC	JC8118	×			
	JC8050	×			
	JC7560	×			
	JC7550		×		
	JC7518		×		
	DH102			○	◎
	DS118				
	DS150				
Grey cast iron (FC, FCD) below 300HB	JC8118	◎			
	JC8050	○			
	JC7560	●			
	JC7550				
	JC7518				
	DH102				
	DS118				
	DS150				
Stainless steel (SUS304) below 250HB	JC8118	●			
	JC8050				
	JC7560				
	JC7550		○		
	JC7518				
	DH102				
	DS118				
	DS150		◎		
Titanium alloy (Ti-6Al-4V)	JC8118	●			
	JC8050				
	JC7560				
	JC7550		○		
	JC7518				
	DH102				
	DS118				
	DS150		◎		
Heat resistant alloy (INCO718)	JC8118	●			
	JC8050				
	JC7560				
	JC7550				
	JC7518		○		
	DH102				
	DS118		◎		
	DS150				

◎ : First choice ○ : For general milling ● : For unstable milling ☆ : For light cutting resistance × : Not recommended

Definition of Corner Shape for Programming

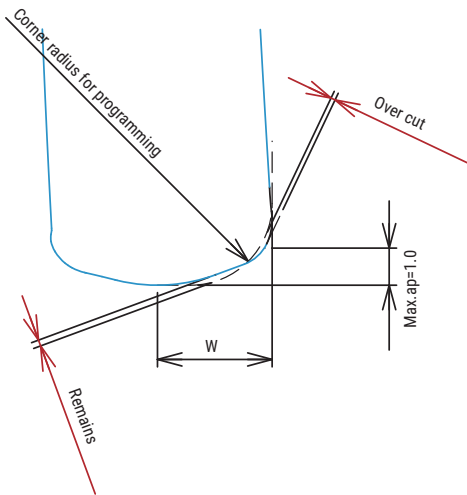

Cat.No.	W	Corner radius for programming	Remains	Over cut
ENMU100412ZER-PH	3.1	1.0	0.51	0
ENMU100412ZER-SL		1.5 (Standard)	0.36	0
		2.0	0.22	0.05

(mm)

Cat.No.	W	Corner radius for programming	Remains	Over cut
ENMU100312ZER-HL	3.3	1.0	0.55	0
ENMQ100312ZER		1.5 (Standard)	0.41	0
		2.0	0.26	0.04

(mm)

Recommended Data for Profile Milling

Ramping

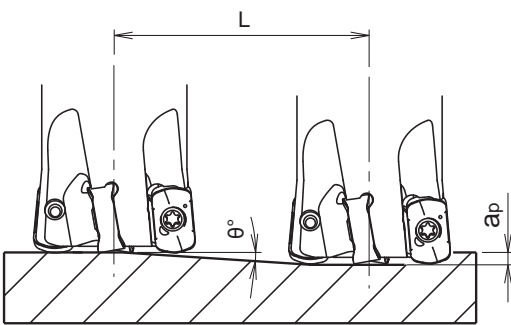

Helical interpolation

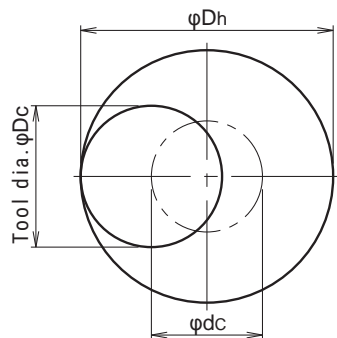

● Calculation of tool pass dia.

$$\varphi_{dc} = \varphi_{Dh} - \varphi_{Dc}$$

Tool pass dia. Bore dia. Tool dia.

- Depth of cut per one circuit should not exceed max. depth of cut A_p
- Down cutting is recommended, tool pass rotation should be counterclockwise

- In case of ramping and helical interpolation, apply 70% or less feed (V_f) from standard cutting condition table
- In case of drilling, apply 50% or less Z axis feed (F) from standard cutting condition table
- Long consecutive chips may result in case of drilling, confirm safe operating conditions

Cat.No.	Tool dia.	Effective Cutting dia.		Max. depth of cut: ap	Ramping	
		Insert			Ramping Max. ramping Angle θ	Max. depth of cut (ap) Total cutting length : L (mm)
		ENMU100412ZER-※※	ENM※100312ZER-※※			
MXG-2016-M8	16	10.1	9.6	0.7	1°36'	25.1
MXG-2017-M8	17	11	10.5	0.7	1°36'	25.1
MXG-3020-M10	20	13.9	13.5	1	1°30'	38.2
MXG-3021-M10	21	14.9	14.5	1	1°30'	38.2
MXG-※025-M12	25	18.9	18.4	1	1°12'	47.7
MXG-4026-M12	26	19.9	19.4	1	1°12'	47.7
MXG-5030-M16	30	23.9	23.4	1	0°54'	63.6
MXG-5032-M16	32	25.8	25.4	1	0°54'	63.6
MXG-5035-M16	35	28.8	28.4	1	0°42'	81.8
MXG-6040-M16	40	33.8	33.4	1	0°30'	114.5
MXG-6042-M16	42	35.8	35.4	1	0°30'	114.5
GMX-2016-※※-S16	16	10.1	9.6	0.7	1°36'	25.1
GMX-3020-※※-S20	20	13.9	13.5	1	1°30'	38.2
GMX-4025-※※-S25	25	18.9	18.4	1	1°12'	47.7
GMX-5032-※※-S32	32	25.8	25.4	1	0°54'	63.6
GMX-7050R-※※	50	43.8	43.4	1	0°24'	143.2
GMX-7052R-22	52	45.8	45.4	1	0°24'	143.2
GMX-7063R-※※	63	56.8	56.4	1	0°18'	190.9
GMX-7066R-※※	66	59.8	59.4	1	0°18'	190.9

Cat.No.	Tool dia.	Helical interpolation			Max.drilling depth : Z	
		Min.Bore dia.		Max. Bore dia.	Insert	
		ENMU100412ZER-※※	ENM※100312ZER-※※		ENMU100412ZER-※※	ENM※100312ZER-※※
MXG-2016-M8	16	22	21	30	0.3	0.2
MXG-2017-M8	17	24	23	32	0.3	0.2
MXG-3020-M10	20	30	29	38	0.4	0.2
MXG-3021-M10	21	32	31	40	0.4	0.2
MXG-※025-M12	25	40	39	48	0.5	0.3
MXG-4026-M12	26	42	41	50	0.5	0.3
MXG-5030-M16	30	50	49	58	0.6	0.4
MXG-5032-M16	32	54	53	62	0.6	0.4
MXG-5035-M16	35	60	59	68	0.6	0.4
MXG-6040-M16	40	70	69	78	0.7	0.5
MXG-6042-M16	42	74	73	82	0.7	0.5
GMX-2016-※※-S16	16	22	21	30	0.3	0.2
GMX-3020-※※-S20	20	30	29	38	0.4	0.2
GMX-4025-※※-S25	25	40	39	48	0.5	0.3
GMX-5032-※※-S32	32	54	53	62	0.6	0.4
GMX-7050R-※※	50	90	89	98	0.8	0.6
GMX-7052R-22	52	94	93	102	0.8	0.6
GMX-7063R-※※	63	116	115	124	0.8	0.6
GMX-7066R-※※	66	122	121	130	0.8	0.6

Recommended Cutting Conditions

Material	Insert	Grade	Vc	fz	ap	ae
Carbon Steel below 250HB	- PH	JC8050 (JC7560)	130 - 180	1.2	0.4 - 1.0	0.7 Dc
Tool & Die Steel below 255HB	- PH	JC8050 (JC7560)	130 - 180	1.2	0.4 - 1.0	0.7 Dc
Mold Steel 30-36HRC	- PH	JC8050 (JC7560)	130 - 160	1.2	0.4 - 1.0	0.7 Dc
Mold Steel 38-43HRC	- PH	JC8118 (JC8050)	70 - 100	0.8 - 1.1	0.3 - 0.8	0.7 Dc
Hardened Die Steel 42-52HRC	- PH (- SL)	JC8118 (JC7518)	70 - 90	0.8 - 1.1	0.1 - 0.6	0.6 Dc
Hardened Die Steel 55-62HRC	ENMQ (- HL)	DH102	60 - 80	0.25 - 0.3	0.1 - 0.2	0.4 Dc
Grey Cast Iron	- PH	JC8118 (JC8050)	150 - 200	1.2 - 1.5	0.4 - 1.0	0.7 Dc
Nodular Cast Iron	- PH	JC8118 (JC8050)	150 - 200	1.2 - 1.5	0.4 - 1.0	0.7 Dc
Austenitic Stainless Steel	- SL	JC7550 (JC7518)	100 - 120	0.8 - 1.0	0.3 - 0.8	0.6 Dc
Precipitation hardening Stainless Steel	- SL (- PH)	JC7550 (JC8050)	90 - 100	0.6 - 0.7	0.2 - 0.6	0.6 Dc
Duplex Stainless Steel	-SL (-PH)	JC7550 (JC8050)	90 - 100	0.2 - 0.3	0.3 - 0.8	0.6 Dc
Titanium Alloy	- SL	DS150 (DS118)	50 - 60	0.6 - 0.7	0.3 - 0.7	0.6 Dc
Heat Resistant Alloy	- SL	JC7518 (JC7550)	20 - 30	0.3	0.2~0.7	0.6 Dc

Note

1. Please adjust cutting conditions according to machine rigidity or work rigidity. (the above table is guide for cutting on a BT50 machine.)
2. In case of chatter occurring, recommended to reduce ap or rpm and keep feed per tooth.
3. ap should be reduced when using on low rigidity machine.
4. Use air blow.

QM *Quick & Mini* MAX

New generation high feed mill "QM MAX"

Modular Type
 $\phi 16 \sim \phi 42$

Bore Type
 $\phi 40 \sim \phi 66$

G-
Body

Shank Type
 $\phi 16 \sim \phi 25$



Low cutting force geometry

Unique 3D geometry insert provides stable cutting and less power consumption.

Multi - flutes specification

High speed and high efficient machining.

Vibration free

Control vibration with combination of MSN carbide shank holder

QM MAX

MQX/QXP Type

Insert Line-Up

High feed insert

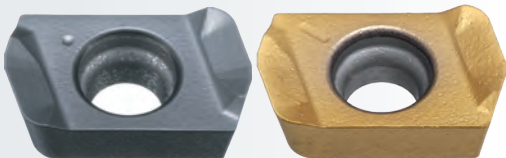

EPMT100312ZER

EPMT100312ZER

High feed insert for unfavorable conditions

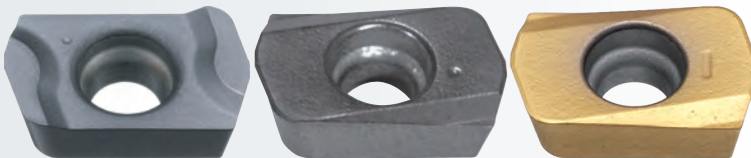

EPMW100312ZER

EPMW100312ZTR

EPMW100312ZTR

For high hardened steel

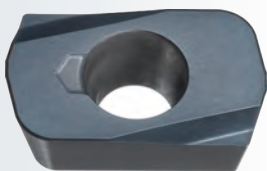

EPHW100316ZTR

Shoulder insert for aluminum

ZPMT1003...ZER-NL
(R0.4, 0.8, 2.0)

Shoulder insert for general steel

ZPMT1003...ZER-PL
(R0.4, 0.8, 2.0)

Shoulder insert for Ti alloy

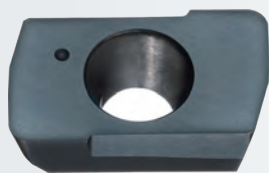
ZPMT1003...ZER-SL
(R0.4, 0.8, 2.0)"Mirror Insert"
for finishing side & bottom face

YPHW1003...ZER-...

CBN insert



YPHW100308ZTR-F1

A variety of inserts all fit into the same body.

Multi-purpose cutter that can high feed, square up and finish.

QXP
TYPE

Bore Type

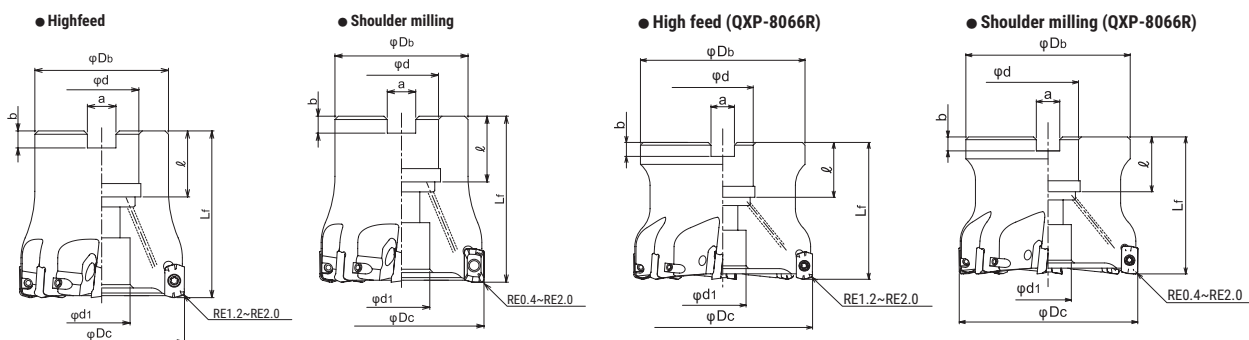

Cat.No.	Stock	No. of inserts	Dimensions (mm)								Insert
			φDc	Lf	φDb	φd	φd1	a	b	ℓ	
QXP-6040R-16	●	6	40	45	35	16	14	8.4	5.6	18	EP**1003**Z*R ZPMT1003**ZER** YPHW1003**Z*R**
QXP-7040R-16	●	7									
QXP-7050R-22	●	8	50	50	40	22	17	10.4	6.3	20	
QXP-8050R-22	●										
QXP-8052R-22	●										
QXP-8063R-22	●				48	27	20	12.4	7	22	
QXP-8066R-27	●										

Screw	Torque(N.m)	Wrench
DSW-2563H	1.1	A-08

QM MAX **MQX/QXP Type**

QXPS
TYPE

Shank Type

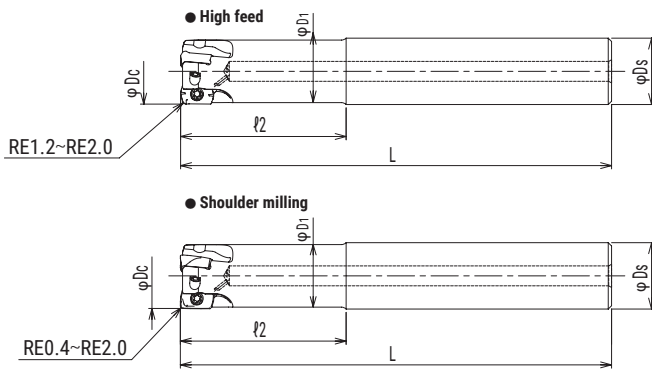

Cat.No	Stock	No. of inserts	Dimensions (mm)					Parts		Insert
			φDc	φ2	L	φD1	φDs	Screw	Wrench	
QXPS2016S16+A	●	2	16	30	100	15	16	TSW-2556H	A-08	EP**1003**Z*R ZPMT1003**ZER-** YPHW1003**Z*R-**
QXPS3020S20+A	●	3	20	50	130	18.85	20			
QXPS4025S25+A	●	4	25	60	140	23.6	25	DSW-2563H		

Screw	Torque(N.m)
TSW-2556H	1.1
DSW-2563H	

MQX
TYPE

Modular Type

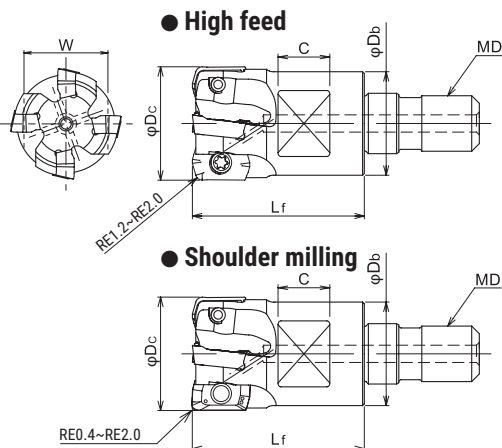

Cat.No.	Stock	No. of inserts	Dimensions (mm)						Parts		Insert
			φDc	Lf	φDb	MD	C	W	Screw	Wrench	
MQX-2016-M8	●	2	16	23	14	M8	8	12	TSW-2556H	A-08	EP**1003**Z*R ZPMT1003**ZER-** YPHW1003**Z*R-**
MQX-2017-M8	●		17								
MQX-3020-M10	●	3	20	30	18	M10	9	14			
MQX-4020-M10	●		4								
MQX-4021-M10	●	5		25	35	22.5	M12	10			
MQX-4025-M12	●		4								
MQX-5025-M12	●	5		28	23.6	M12	12	22			
MQX-4026-M12	○		5						30	27	M16
MQX-5026-M12	●	6		32	29	M16					
MQX-5028-M12	○		5				35	M16			
MQX-5030-M16	○	6		40	32	M16			14	26	
MQX-5032-M16	●		6				42	M16			
MQX-6032-M16	●	6		35	M16						
MQX-5035-M16	●		7			40	M16				
MQX-6035-M16	●	6		42	M16						
MQX-6040-M16	●		6			42	M16				
MQX-7040-M16	●	6		42	M16						
MQX-6042-M16	●		6			42	M16				

Screw	Torque(N.m)
TSW-2556H	1.1
DSW-2563H	

QM MAX **MQX/QXP Type**

Insert

High feed insert
(EPMT1003 * * ZER)

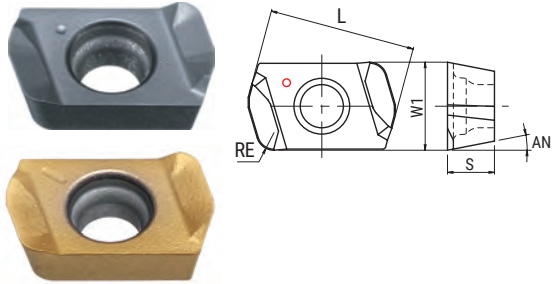

Shoulder insert for general steel
(ZPMT1003 * * ZER-PL)

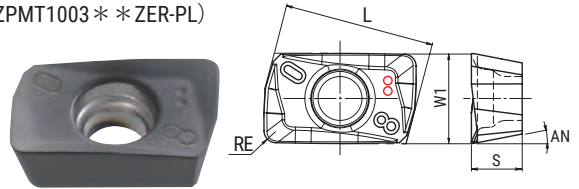

Shoulder insert for Ti alloy
(ZPMT1003 * * ZER-SL)

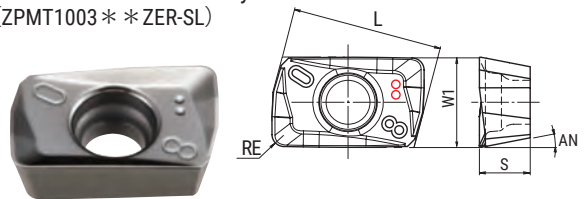

High feed insert for unfavorable conditions
(EPMW100312ZER)

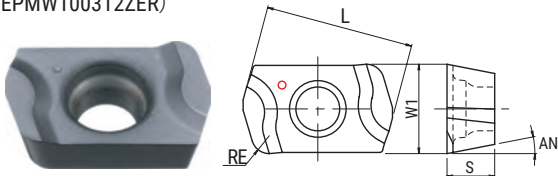

"Mirror Insert" for finishing side & bottom face
(YPHW1003 * * ZER-15) (YPHW100308ZTR-F1) (YPHW100308ZER-F)

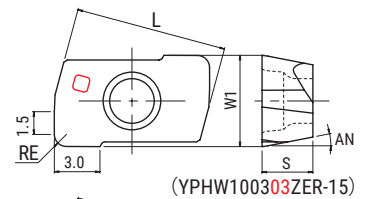

High feed insert for unfavorable conditions
(EPMW100312ZTR)

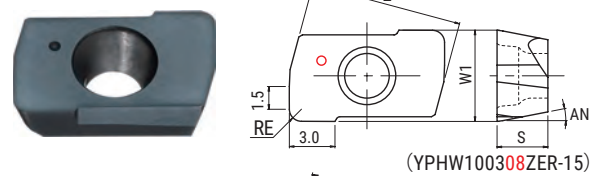
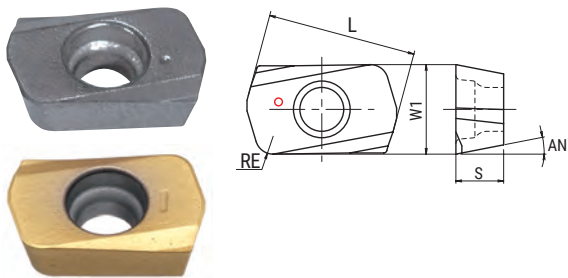

For high hardened steel
(EPHW100316ZTR)

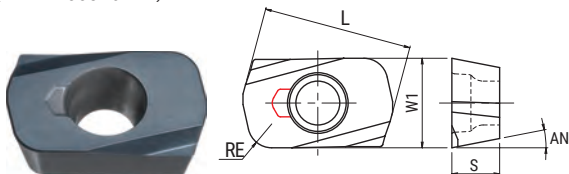

CBN insert

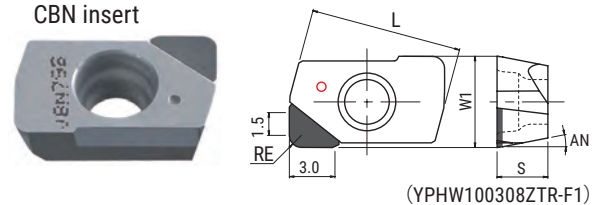

Shoulder insert for aluminum
(ZPMT1003 * * ZER-NL)

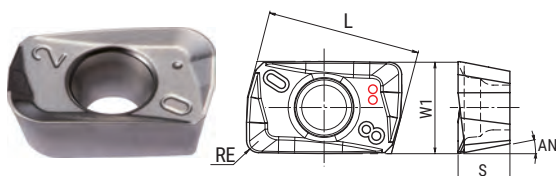

"Mirror Insert" for finishing side & bottom face
(YPHW100320ZER-24)

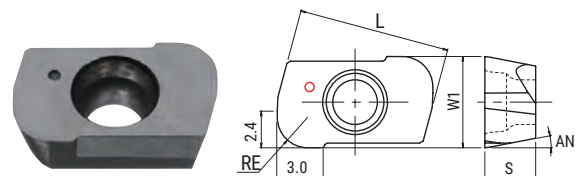

Type	Cat.No.	Tolerance	PVD coating								Uncoated	Cermet	CBN	Dimensions (mm)				
			JC8118	DH102	JC7518	JC7560	JC8015	JC8050	DS118	DS150				FC18	CX75	JBN795	L	S
High feed insert	EPMT100312ZER	M	●			●		●	●	●				10	3.2	6	1.2	11°
	EPMT100320ZER	M	●											10	3.2	6	2.0	11°
High feed insert for unfavorable conditions	EPMW100312ZER	M	●					●						10	3.2	6	1.2	11°
	EPMW100312ZTR	M	●			●		●						10	3.2	6	1.2	11°
For high hardened steel	EPHW100316ZTR	H	●	●										10	3.2	6	1.6	11°
Shoulder insert for aluminum	ZPMT100304ZER-NL	M									●			10.08	3.4	6	0.4	11°
	ZPMT100308ZER-NL	M									●			10.08	3.4	6	0.8	11°
	ZPMT100320ZER-NL	M									●			10.08	3.4	6	2.0	11°
Shoulder insert for general steel	ZPMT100304ZER-PL	M	●	●				●			●			10.08	3.4	6	0.4	11°
	ZPMT100308ZER-PL	M	●	●				●			●			10.08	3.4	6	0.8	11°
	ZPMT100320ZER-PL	M	●	●				●			●			10.08	3.4	6	2.0	11°
Shoulder insert for Ti alloy	ZPMT100304ZER-SL	M			●				●					10.08	3.4	6	0.4	11°
	ZPMT100308ZER-SL	M			●				●					10.08	3.4	6	0.8	11°
	ZPMT100320ZER-SL	M			●				●					10.08	3.4	6	2.0	11°
"Mirror Insert" for finishing side & bottom face	YPHW100303ZER-15	H	●				●				●			10.06	3.35	6	0.3	11°
	YPHW100308ZER-15	H	●								●			10.06	3.35	6	0.8	11°
	YPHW100308ZER-F	H					●							10.06	3.35	6	0.8	11°
	YPHW100308ZTR-F1	H										●		10.06	3.35	6	0.8	11°
	YPHW100320ZER-24	H	●				●							10.06	3.35	6	2.0	11°

GRADE MARKING



JC8118 / DS118

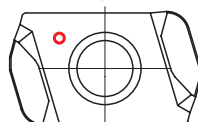

JC8050 / JC7560 / DS150

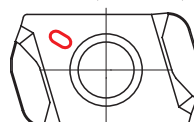

QM MAX

MQX/QXP Type

Insert selection guide

Material	Carbon steel (S50C, S55C) below 250HB						Tool & die steel (SKD61, SKD11) below 255HB						Mold steel (HPM7, PX5, P20) 30-36HRC						Mold steel (NAK80, HPM1, P21) 38-43HRC					
	Cat.No.	Grade					Cat.No.	Grade					Cat.No.	Grade					Cat.No.	Grade				
EPMT1003**ZER	☆	☆	☆				☆	☆	☆				☆	☆	☆				☆	☆				
EPMW100312ZER																			○					
EPMW100312ZTR	○	○	◎				○	○	◎				○	○	◎				◎	○				
EPHW100316ZTR																								

Material	Hardened die steel (SKD61, DAC, DHA) 42-52 HRC						Hardened die steel (SKD11, SLD, DC11) 55-62HRC						Grey cast iron (FC, FCD) below 300HB						Stainless steel (SUS304) below 250HB					
	Cat.No.	Grade					Cat.No.	Grade					Cat.No.	Grade					Cat.No.	Grade				
EPMT1003**ZER	☆						×	×					○						◎	○				
EPMW100312ZER	○						○						◎						●					
EPMW100312ZTR	●						●						●	○										
EPHW100316ZTR	◎									◎														

Material	Titanium alloy (Ti-6Al-4V)						Heat resistant alloy (INCO718)					
	Cat.No.	Grade					Cat.No.	Grade				
EPMT1003**ZER	○	○	●		○	◎	◎	○	○		○	○
EPMW100312ZER		●						●				
EPMW100312ZTR												
EPHW100316ZTR												

- EPMT Type : with chip breaker
- EPMW Type : without chip breaker
- EPMW Type : without chip breaker

- ◎ : First choice
- : For general milling
- : For unstable milling
- ☆ : For light cutting force
- × : Not recommended

Definition of corner shape for programming

• EPMT/W Type (RE=R1.2)

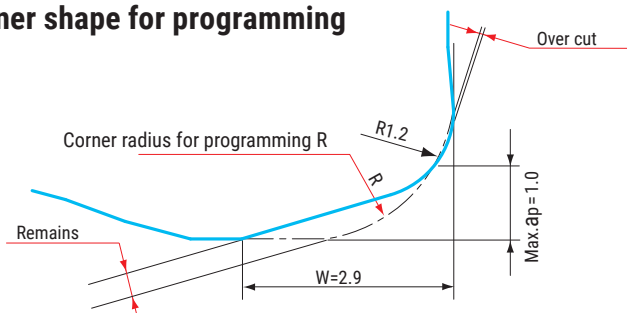

Corner radius for programming R	Over cut	Remains
R1.0	0	0.57
R1.5 (Std.)	0	0.45
R2.0	0.04	0.33
R2.5	0.21	0.21
R3.0	0.40	0.09

• EPMT Type (RE=R2.0)

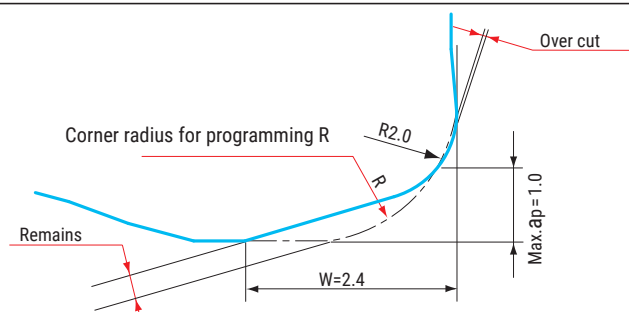

Corner radius for programming R	Over cut	Remains
R1.0	0	0.51
R1.5	0	0.31
R2.0 (Std.)	0	0.13
R2.5	0.12	0.04
R3.0	0.32	0

• EPHW Type

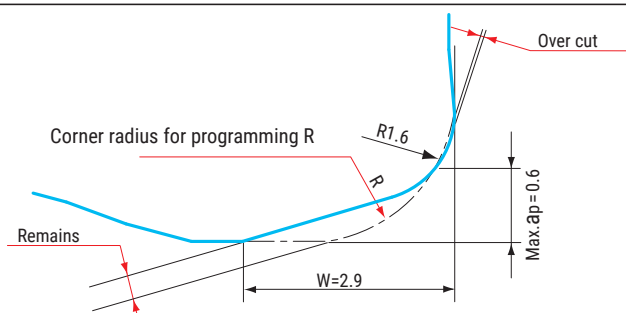

Corner radius for programming R	Over cut	Remains
R1.0	0	0.42
R1.5 (Std.)	0	0.33
R2.0	0.01	0.23
R2.5	0.17	0.14
R3.0	0.37	0.05

QM MAX

MQX/QXP Type

Recommended Data for Profile Milling

Ramping

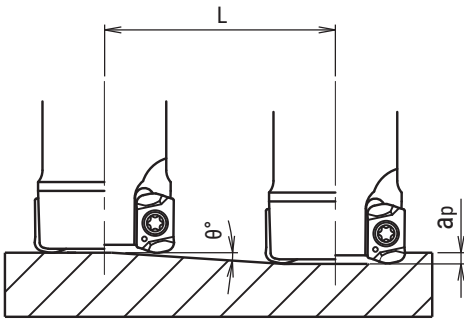

Helical interpolation

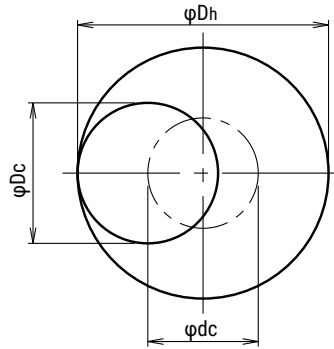

- Calculation of tool pass dia.

$$\varphi_{dc} = \varphi_{Dh} - \varphi_{Dc}$$

Tool pass dia. Bore dia. Tool Dia.

- Depth of cut per one circuit should not exceed max. depth of cut A_p
- Down cutting is recommended, tool pass rotation should be counterclockwise

- In case of ramping and helical interpolation, apply 70% or less feed (V_f) from standard cutting condition table
- In case of drilling, apply 50% or less Z axis feed (F) from standard cutting condition table
- Long consecutive chips may result in case of drilling, confirm safe operating conditions

EPM*100312ZER

Cat.No.	Tool dia.	Effective Cutting dia.	Max.depth of cut : a_p	Ramping		Helical interpolation		Max.drilling depth Z(mm)
				Max.ramping angle θ	Max.depth of cut (a_p) Total cutting length L (mm)	Min.Bore dia.	Max.Bore dia.	
QXP-*040R-16	40	34.1	1	0.5	114.6	70	78	0.6
QXP-*050R-**	50	44.1	1	0.4	143.2	90	98	0.6
QXP-8052R-22	52	46.1	1	0.35	163.7	94	102	0.6
QXP-8063R-**	63	57.1	1	0.3	191	116	124	0.6
QXP-8066R-**	66	60.1	1	0.3	191	122	130	0.6
QXPS2016S16+A	16	10.2	0.8	1.8	25.5	22	30	0.6
QXPS3020S20+A	20	14.1	0.8	1.4	32.7	30	38	0.6
QXPS4025S25+A	25	19.1	0.8	1	45.8	40	48	0.6
MQX-*016-M8	16	10.2	0.8	1.8	25.5	22	30	0.6
MQX-*017-M8	17	11.2	0.8	1.6	28.6	24	32	0.6
MQX-*020-M10	20	14.1	0.8	1.4	32.7	30	38	0.6
MQX-*021-M10	21	15.1	0.8	1.3	35.3	32	40	0.6
MQX-*025-M12	25	19.1	0.8	1	45.8	40	48	0.6
MQX-*026-M12	26	20.1	0.8	0.95	48.2	42	50	0.6
MQX-*028-M12	28	22.1	0.8	0.85	53.9	46	54	0.6
MQX-*030-M16	30	24.1	0.8	0.8	57.3	50	58	0.5
MQX-*032-M16	32	26.1	0.8	0.7	65.5	54	62	0.5
MQX-*035-M16	35	29.1	0.8	0.6	76.4	60	68	0.5
MQX-*040-M16	40	34.1	0.8	0.5	91.7	70	78	0.6
MQX-*042-M16	42	36.2	0.8	0.45	101.9	74	82	0.6

QM MAX

MQX/QXP Type

■ Recommended Data for Profile Milling

■ EPMT100320ZER

Cat.No.	Tool dia.	Effective Cutting dia.	Max.depth of cut : ap	Ramping		Helical interpolation		Max.drilling depth Z(mm)
				Max.ramping angle θ	Max.depth of cut (ap) Total cutting length L (mm)	Min.Bore dia.	Max.Bore dia.	
QXP- *040R-16	40	35.1	1	0.55	104.2	72	78	0.7
QXP- *050R- * *	50	45.1	1	0.4	143.2	92	98	0.7
QXP-8052R-22	52	47.2	1	0.4	143.2	96	102	0.7
QXP-8063R- * *	63	58.2	1	0.3	191	118	124	0.7
QXP-8066R- * *	66	61.2	1	0.3	191	124	130	0.7
QXPS2016S16+A	16	11.2	0.8	2.3	19.9	24	30	0.7
QXPS3020S20+A	20	15.1	0.8	1.5	30.6	32	38	0.7
QXPS4025S25+A	25	20.1	0.8	1.1	41.7	42	48	0.6
MQX- *016-M8	16	11.2	0.8	2.3	19.9	24	30	0.7
MQX- *017-M8	17	12.2	0.8	2	22.9	26	32	0.7
MQX- *020-M10	20	15.1	0.8	1.5	30.6	32	38	0.7
MQX- *021-M10	21	16.1	0.8	1.4	32.7	34	40	0.7
MQX- *025-M12	25	20.1	0.8	1.1	41.7	42	48	0.6
MQX- *026-M12	26	21.1	0.8	1	45.8	44	50	0.6
MQX- *028-M12	28	23.1	0.8	0.9	50.9	48	54	0.6
MQX- *030-M16	30	25.1	0.8	0.85	53.9	52	58	0.6
MQX- *032-M16	32	27.1	0.8	0.75	61.1	56	62	0.6
MQX- *035-M16	35	30.1	0.8	0.65	70.5	62	68	0.6
MQX- *040-M16	40	35.1	0.8	0.55	83.3	72	78	0.7
MQX- *042-M16	42	37.1	0.8	0.55	83.3	76	82	0.7

■ EPMW100312ZTR

Cat.No.	Tool dia.	Effective Cutting dia.	Max.depth of cut : ap	Ramping		Helical interpolation		Max.drilling depth Z(mm)
				Max.ramping angle θ	Max.depth of cut (ap) Total cutting length L (mm)	Min.Bore dia.	Max.Bore dia.	
QXP- *040R-16	40	34.1	1	0.4	143.2	70	78	0.6
QXP- *050R- * *	50	44.1	1	0.3	191	90	98	0.6
QXP-8052R-22	52	46.1	1	0.25	229.2	94	102	0.6
QXP-8063R- * *	63	57.1	1	0.2	286.5	116	124	0.6
QXP-8066R- * *	66	60.1	1	0.2	286.5	122	130	0.6
QXPS2016S16+A	16	10.2	0.8	1.7	27	22	30	0.6
QXPS3020S20+A	20	14.1	0.8	1.3	35.3	30	38	0.6
QXPS4025S25+A	25	19.1	0.8	0.9	50.9	40	48	0.6
MQX- *016-M8	16	10.2	0.8	1.7	27	22	30	0.6
MQX- *017-M8	17	11.2	0.8	1.5	30.6	24	32	0.6
MQX- *020-M10	20	14.1	0.8	1.3	35.3	30	38	0.6
MQX- *021-M10	21	15.1	0.8	1.2	38.2	32	40	0.6
MQX- *025-M12	25	19.1	0.8	0.9	50.9	40	48	0.6
MQX- *026-M12	26	20.1	0.8	0.85	53.9	42	50	0.6
MQX- *028-M12	28	22.1	0.8	0.75	61.1	46	54	0.6
MQX- *030-M16	30	24.1	0.8	0.7	65.5	50	58	0.5
MQX- *032-M16	32	26.1	0.8	0.6	76.4	54	62	0.5
MQX- *035-M16	35	29.1	0.8	0.5	91.7	60	68	0.5
MQX- *040-M16	40	34.1	0.8	0.4	114.6	70	78	0.6
MQX- *042-M16	42	36.2	0.8	0.35	131	74	82	0.6

QM MAX

MQX/QXP Type

EPHW100316ZTR

Cat.No.	Tool dia.	Effective Cutting dia.	Max.depth of cut : ap	Ramping		Helical interpolation		Max.drilling depth Z(mm)
				Max.ramping angle θ	Max.depth of cut (ap) Total cutting length L (mm)	Min.Bore dia.	Max.Bore dia.	
QXP-*040R-16	40	34.1	0.6	0.3	114.6	70	78	0.6
QXP-*050R-***	50	44.1	0.6	0.2	171.9	90	98	0.6
QXP-8052R-22	52	46.1	0.6	0.2	171.9	94	102	0.6
QXP-8063R-***	63	57.1	0.6	0.15	229.2	116	124	0.6
QXP-8066R-***	66	60.1	0.6	0.15	229.2	122	130	0.6
QXPS2016S16+A	16	10.2	0.6	1.1	31.2	22	30	0.6
QXPS3020S20+A	20	14.1	0.6	0.8	43	30	38	0.6
QXPS4025S25+A	25	19.1	0.6	0.55	62.5	40	48	0.6
MQX-*016-M8	16	10.2	0.6	1.1	31.2	22	30	0.6
MQX-*017-M8	17	11.2	0.6	1	34.4	24	32	0.6
MQX-*020-M10	20	14.1	0.6	0.8	43	30	38	0.6
MQX-*021-M10	21	15.1	0.6	0.7	49.1	32	40	0.6
MQX-*025-M12	25	19.1	0.6	0.55	62.5	40	48	0.6
MQX-*026-M12	26	20.1	0.6	0.5	68.8	42	50	0.6
MQX-*028-M12	28	22.1	0.6	0.45	76.4	46	54	0.6
MQX-*030-M16	30	24.1	0.6	0.4	85.9	50	58	0.5
MQX-*032-M16	32	26.1	0.6	0.4	85.9	54	62	0.5
MQX-*035-M16	35	29.1	0.6	0.35	98.2	60	68	0.5
MQX-*040-M16	40	34.1	0.6	0.3	114.6	70	78	0.6
MQX-*042-M16	42	36.2	0.6	0.25	137.5	74	82	0.6

ZPMT100304ZER-**

Cat.No.	Tool dia.	Effective Cutting dia.	Max.depth of cut : ap	Ramping		Helical interpolation		Max.drilling depth Z(mm)
				Max.ramping angle θ	Max.depth of cut (ap) Total cutting length L (mm)	Min.Bore dia.	Max.Bore dia.	
QXP-*040R-16	40	39	1	0.95	60.3	75.6	78.4	0.6
QXP-*050R-***	50	49	1	0.7	81.8	95.6	98.4	0.6
QXP-8052R-22	52	51	1	0.65	88.1	99.6	102.4	0.6
QXP-8063R-***	63	62	1	0.55	104.2	121.6	124.4	0.6
QXP-8066R-***	66	65	1	0.5	114.6	127.6	130.4	0.6
QXPS2016S16+A	16	15	0.8	3	15.3	27.6	30.4	0.6
QXPS3020S20+A	20	19	0.8	2.4	19.1	35.6	38.4	0.6
QXPS4025S25+A	25	24	0.8	1.7	27	45.6	48.4	0.6
MQX-*016-M8	16	15	0.8	3	15.3	27.6	30.4	0.6
MQX-*017-M8	17	16	0.8	3.2	14.3	29.6	32.4	0.6
MQX-*020-M10	20	19	0.8	2.4	19.1	35.6	38.4	0.6
MQX-*021-M10	21	20	0.8	2.2	20.8	37.6	40.4	0.6
MQX-*025-M12	25	24	0.8	1.7	27	45.6	48.4	0.6
MQX-*026-M12	26	25	0.8	1.6	28.6	47.6	50.4	0.6
MQX-*028-M12	28	27	0.8	1.5	30.6	51.6	54.4	0.6
MQX-*030-M16	30	29	0.8	1.3	35.3	55.6	58.4	0.5
MQX-*032-M16	32	31	0.8	1.2	38.2	59.6	62.4	0.5
MQX-*035-M16	35	34	0.8	1.1	41.7	65.6	68.4	0.5
MQX-*040-M16	40	39	0.8	0.95	48.2	75.6	78.4	0.6
MQX-*042-M16	42	41	0.8	0.85	53.9	79.6	82.4	0.6

QM MAX

MQX/QXP Type

■ Recommended Data for Profile Milling

■ ZPMT100308ZER-**

Cat.No.	Tool dia.	Effective Cutting dia.	Max.depth of cut : ap	Ramping		Helical interpolation		Max.drilling depth Z(mm)
				Max.ramping angle θ	Max.depth of cut (ap) Total cutting length L (mm)	Min.Bore dia.	Max.Bore dia.	
QXP- * 040R-16	40	38.2	1	0.95	60.3	74.8	77.6	0.6
QXP- * 050R- * *	50	48.2	1	0.7	81.8	94.8	97.6	0.6
QXP-8052R-22	52	50.2	1	0.65	88.1	98.8	101.6	0.6
QXP-8063R- * *	63	61.2	1	0.55	104.2	120.8	123.6	0.6
QXP-8066R- * *	66	64.2	1	0.5	114.6	126.8	129.6	0.6
QXPS2016S16+A	16	14.2	0.8	3	15.3	26.8	29.6	0.6
QXPS3020S20+A	20	18.2	0.8	2.4	19.1	34.8	37.6	0.6
QXPS4025S25+A	25	23.2	0.8	1.7	27	44.8	47.6	0.6
MQX- * 016-M8	16	14.2	0.8	3	15.3	26.8	29.6	0.6
MQX- * 017-M8	17	15.2	0.8	3.2	14.3	28.8	31.6	0.6
MQX- * 020-M10	20	18.2	0.8	2.4	19.1	34.8	37.6	0.6
MQX- * 021-M10	21	19.2	0.8	2.2	20.8	36.8	39.6	0.6
MQX- * 025-M12	25	23.2	0.8	1.7	27	44.8	47.6	0.6
MQX- * 026-M12	26	24.2	0.8	1.6	28.6	46.8	49.6	0.6
MQX- * 028-M12	28	26.2	0.8	1.5	30.6	50.8	53.6	0.6
MQX- * 030-M16	30	28.2	0.8	1.3	35.3	54.8	57.6	0.5
MQX- * 032-M16	32	30.2	0.8	1.2	38.2	58.8	61.6	0.5
MQX- * 035-M16	35	33.2	0.8	1.1	41.7	64.8	67.6	0.5
MQX- * 040-M16	40	38.2	0.8	0.95	48.2	74.8	77.6	0.6
MQX- * 042-M16	42	40.2	0.8	0.85	53.9	78.8	81.6	0.6

■ ZPMT100320ZER-**

Cat.No.	Tool dia.	Effective Cutting dia.	Max.depth of cut : ap	Ramping		Helical interpolation		Max.drilling depth Z(mm)
				Max.ramping angle θ	Max.depth of cut (ap) Total cutting length L (mm)	Min.Bore dia.	Max.Bore dia.	
QXP- * 040R-16	40	35.8	1	0.95	60.3	70	75.2	0.6
QXP- * 050R- * *	50	45.8	1	0.7	81.8	90	95.2	0.6
QXP-8052R-22	52	47.8	1	0.65	88.1	94	99.2	0.6
QXP-8063R- * *	63	58.8	1	0.55	104.2	116	121.2	0.6
QXP-8066R- * *	66	61.8	1	0.5	114.6	122	127.2	0.6
QXPS2016S16+A	16	11.8	0.8	3	15.3	22	27.2	0.6
QXPS3020S20+A	20	15.8	0.8	2.4	19.1	30	35.2	0.6
QXPS4025S25+A	25	20.8	0.8	1.7	27	40	45.2	0.6
MQX- * 016-M8	16	11.8	0.8	3	15.3	22	27.2	0.6
MQX- * 017-M8	17	12.8	0.8	3.2	14.3	24	29.2	0.6
MQX- * 020-M10	20	15.8	0.8	2.4	19.1	30	35.2	0.6
MQX- * 021-M10	21	16.8	0.8	2.2	20.8	32	37.2	0.6
MQX- * 025-M12	25	20.8	0.8	1.7	27	40	45.2	0.6
MQX- * 026-M12	26	21.8	0.8	1.6	28.6	42	47.2	0.6
MQX- * 028-M12	28	23.8	0.8	1.5	30.6	46	51.2	0.6
MQX- * 030-M16	30	25.8	0.8	1.3	35.3	50	55.2	0.5
MQX- * 032-M16	32	27.8	0.8	1.2	38.2	54	59.2	0.5
MQX- * 035-M16	35	30.8	0.8	1.1	41.7	60	65.2	0.5
MQX- * 040-M16	40	35.8	0.8	0.95	48.2	70	75.2	0.6
MQX- * 042-M16	42	37.8	0.8	0.85	53.9	74	79.2	0.6

QM MAX

MQX/QXP Type

YPHW100303ZER-15

Cat.No.	Tool dia.	Effective Cutting dia.	Max.depth of cut : ap	Ramping		Helical interpolation		Max.drilling depth Z(mm)
				Max.ramping angle θ	Max.depth of cut (ap) Total cutting length L (mm)	Min.Bore dia.	Max.Bore dia.	
QXP- *040R-16	40	39.3	0.3	1	17.2	77	78.7	0.3
QXP- *050R- * *	50	49.3	0.3	0.75	22.9	97	98.7	0.3
QXP-8052R-22	52	51.3	0.3	0.7	24.6	101	102.7	0.3
QXP-8063R- * *	63	62.3	0.3	0.6	28.6	123	124.7	0.3
QXP-8066R- * *	66	65.3	0.3	0.55	31.3	129	130.7	0.3
QXPS2016S16+A	16	15.3	0.3	1.3	13.2	29	30.7	0.2
QXPS3020S20+A	20	19.3	0.3	2.1	8.2	37	38.7	0.3
QXPS4025S25+A	25	24.3	0.3	1.8	9.5	47	48.7	0.3
MQX- *016-M8	16	15.3	0.3	1.3	13.2	29	30.7	0.2
MQX- *017-M8	17	16.3	0.3	1.7	10.1	31	32.7	0.3
MQX- *020-M10	20	19.3	0.3	2.1	8.2	37	38.7	0.3
MQX- *021-M10	21	20.3	0.3	2.4	7.2	39	40.7	0.3
MQX- *025-M12	25	24.3	0.3	1.8	9.5	47	48.7	0.3
MQX- *026-M12	26	25.3	0.3	1.7	10.1	49	50.7	0.3
MQX- *028-M12	28	27.3	0.3	1.6	10.7	53	54.7	0.3
MQX- *030-M16	30	29.3	0.3	1.4	12.3	57	58.7	0.3
MQX- *032-M16	32	31.3	0.3	1.3	13.2	61	62.7	0.3
MQX- *035-M16	35	34.3	0.3	1.2	14.3	67	68.7	0.3
MQX- *040-M16	40	39.3	0.3	1	17.2	77	78.7	0.3
MQX- *042-M16	42	41.3	0.3	0.9	19.1	81	82.7	0.3

YPHW100308ZER-15

Cat.No.	Tool dia.	Effective Cutting dia.	Max.depth of cut : ap	Ramping		Helical interpolation		Max.drilling depth Z(mm)
				Max.ramping angle θ	Max.depth of cut (ap) Total cutting length L (mm)	Min.Bore dia.	Max.Bore dia.	
QXP- *040R-16	40	38.3	0.3	1	17.2	75	77.7	0.3
QXP- *050R- * *	50	48.3	0.3	0.75	22.9	95	97.7	0.3
QXP-8052R-22	52	50.3	0.3	0.7	24.6	99	101.7	0.3
QXP-8063R- * *	63	61.3	0.3	0.6	28.6	121	123.7	0.3
QXP-8066R- * *	66	64.3	0.3	0.55	31.3	127	129.7	0.3
QXPS2016S16+A	16	14.3	0.3	1.4	12.3	27	29.7	0.2
QXPS3020S20+A	20	18.3	0.3	2.2	7.8	35	37.7	0.3
QXPS4025S25+A	25	23.3	0.3	1.9	9	45	47.7	0.3
MQX- *016-M8	16	14.3	0.3	1.4	12.3	27	29.7	0.2
MQX- *017-M8	17	15.3	0.3	1.8	9.5	29	31.7	0.3
MQX- *020-M10	20	18.3	0.3	2.2	7.8	35	37.7	0.3
MQX- *021-M10	21	19.3	0.3	2.5	6.9	37	39.7	0.3
MQX- *025-M12	25	23.3	0.3	1.9	9	45	47.7	0.3
MQX- *026-M12	26	24.3	0.3	1.8	9.5	47	49.7	0.3
MQX- *028-M12	28	26.3	0.3	1.7	10.1	51	53.7	0.3
MQX- *030-M16	30	28.3	0.3	1.5	11.5	55	57.7	0.3
MQX- *032-M16	32	30.3	0.3	1.4	12.3	59	61.7	0.3
MQX- *035-M16	35	33.3	0.3	1.2	14.3	65	67.7	0.3
MQX- *040-M16	40	38.3	0.3	1	17.2	75	77.7	0.3
MQX- *042-M16	42	40.3	0.3	0.9	19.1	79	81.7	0.3

QM MAX

MQX/QXP Type

■ Recommended Data for Profile Milling

■ **YPHW100320ZER-24**

Cat.No.	Tool dia.	Effective Cutting dia.	Max.depth of cut : ap	Ramping		Helical interpolation		Max.drilling depth Z(mm)
				Max.ramping angle θ	Max.depth of cut (ap) Total cutting length L (mm)	Min.Bore dia.	Max.Bore dia.	
QXP- * 040R-16	40	35.9	0.3	1.1	15.6	70.2	75.3	0.3
QXP- * 050R- * *	50	45.9	0.3	0.9	19.1	90.2	95.3	0.3
QXP-8052R-22	52	47.9	0.3	0.85	20.2	94.2	99.3	0.3
QXP-8063R- * *	63	58.9	0.3	0.65	26.4	116.2	121.3	0.3
QXP-8066R- * *	66	61.9	0.3	0.65	26.4	122.2	127.3	0.3
QXPS2016S16+A	16	11.9	0.3	1.9	9	22.2	27.3	0.3
QXPS3020S20+A	20	15.9	0.3	2.5	6.9	30.2	35.3	0.3
QXPS4025S25+A	25	20.9	0.3	2.2	7.8	40.2	45.3	0.3
MQX- * 016-M8	16	11.9	0.3	1.9	9	22.2	27.3	0.3
MQX- * 017-M8	17	12.9	0.3	2.2	7.8	24.2	29.3	0.3
MQX- * 020-M10	20	15.9	0.3	2.5	6.9	30.2	35.3	0.3
MQX- * 021-M10	21	16.9	0.3	2.8	6.1	32.2	37.3	0.3
MQX- * 025-M12	25	20.9	0.3	2.2	7.8	40.2	45.3	0.3
MQX- * 026-M12	26	21.9	0.3	2	8.6	42.2	47.3	0.3
MQX- * 028-M12	28	23.9	0.3	1.8	9.5	46.2	51.3	0.3
MQX- * 030-M16	30	25.9	0.3	1.6	10.7	50.2	55.3	0.3
MQX- * 032-M16	32	27.9	0.3	1.5	11.5	54.2	59.3	0.3
MQX- * 035-M16	35	30.9	0.3	1.4	12.3	60.2	65.3	0.3
MQX- * 040-M16	40	35.9	0.3	1.1	15.6	70.2	75.3	0.3
MQX- * 042-M16	42	37.9	0.3	1.1	15.6	74.2	79.3	0.3

Recommended Cutting Conditions

Material		High Feed		Shoulder Milling	Side Finishing	Bottom Finishing
		EPMT / EPMW	EPHW	ZPMT		
Carbon Steel below 250HB	Grade	JC7560 (JC8050 JC8118)	-	JC8050 (JC8118)	JC8050 (JC8118)	JC8050 (JC8118)
	Vc	130 - 180	-	130 - 160	190 - 320	90 - 180
	fz	0.7 - 0.9	-	0.12 - 0.15	0.18 - 0.30	0.1 - 0.15
	ap	0.4 - 1.0	-	~5.0	~5.0	~0.2
	ae	0.7 Dc	-	~0.16 Dc	~0.2	0.4 - 1.0 Dc
Tool & Die Steel below 255HB	Grade	JC7560 (JC8050 JC8118)	-	JC8050 (JC8118)	JC8050 (JC8118)	JC8050 (JC8118)
	Vc	130 - 180	-	120 - 150	180 - 300	80 - 160
	fz	0.7 - 0.9	-	0.12 - 0.15	0.15 - 0.25	0.1 - 0.15
	ap	0.4 - 1.0	-	~5.0	~5.0	~0.2
	ae	0.7 Dc	-	~0.16 Dc	~0.2	0.4 - 1.0 Dc
Mold Steel 30-36HRC	Grade	JC8118 (JC7560 JC8050)	-	JC8118 (JC8050)	JC8118 (JC8050)	JC8118 (JC8050)
	Vc	130 - 180	-	120 - 150	180 - 300	80 - 160
	fz	0.7 - 1.0	-	0.12 - 0.15	0.15 - 0.25	0.1 - 0.15
	ap	0.4 - 1.0	-	~5.0	~5.0	~0.2
	ae	0.7 Dc	-	~0.16 Dc	~0.2	0.4 - 1.0 Dc
Mold Steel 38-43HRC	Grade	JC8118 (JC8050)	-	JC8118 (JC8050)	JC8118 (JC8050)	JC8118 (JC8050)
	Vc	70 - 100	-	100 - 120	150 - 250	70 - 140
	fz	0.6 - 0.7	-	0.1 - 0.12	0.15 - 0.25	0.1 - 0.15
	ap	0.3 - 0.8	-	~4.0	~4.0	~0.2
	ae	0.6 Dc	-	~0.15 Dc	~0.2	0.4 - 1.0 Dc
Hardened Die Steel 42-52HRC	Grade	JC8118	JC8118	JC8118 (DH102)	JC8118 (DH102)	JC8118 (DH102)
	Vc	60 - 70	70 - 90	80 - 100	120 - 210	75 - 100
	fz	0.5	0.5 - 0.8	0.09 - 0.12	0.12 - 0.20	0.1 - 0.12
	ap	0.2 - 0.6	0.1 - 0.3	~3.5	~3.5	~0.2
	ae	0.6 Dc	0.6 Dc	~0.14 Dc	~0.2	0.4 - 1.0 Dc
Hardened Die Steel 55-62HRC	Grade	-	DH102	DH102	DH102	DH102
	Vc	-	60 - 80	50 - 70	100 - 180	50 - 70
	fz	-	0.2 - 0.3	0.1	0.09 - 0.15	0.08 - 0.1
	ap	-	0.1 - 0.2	~2.5	~2.5	~0.15
	ae	-	0.4 Dc	~0.14 Dc	~0.15	0.4 - 1.0 Dc
Grey & Nodular Cast Iron below 300HB	Grade	JC8118	-	JC8118 (DH102)	JC8118 (DH102)	JC8118 (DH102)
	Vc	110 - 150	-	120 - 150	160 - 280	90 - 180
	fz	0.8 - 1.2	-	0.16 - 0.2	0.18 - 0.30	0.12 - 0.18
	ap	0.4 - 1.0	-	~5.0	~5.0	~0.2
	ae	0.7 Dc	-	~0.2 Dc	~0.2	0.4 - 1.0 Dc
Stainless Steel	Grade	JC8050 (JC7560)	-	JC8050 (JC8118 JC7518)	JC8050 (JC8118 JC7518)	JC8050 (JC8118 JC7518)
	Vc	130 - 150	-	120 - 150	180 - 300	80 - 160
	fz	0.6 - 0.8	-	0.12 - 0.15	0.15 - 0.25	0.1 - 0.15
	ap	0.3 - 0.8	-	~5.0	~5.0	~0.2
	ae	0.6 Dc	-	~0.16 Dc	~0.2	0.4 - 1.0 Dc
Titanium Alloy	Grade	DS150 (JC8050 DS118)	-	DS118 (JC7518)	DS118 (JC7518)	DS118 (JC7518)
	Vc	50 - 60	-	50 - 60	60 - 100	25 - 50
	fz	0.4	-	0.12 - 0.15	0.15 - 0.25	0.1 - 0.12
	ap	0.2 - 0.8	-	~5.0	~5.0	~0.2
	ae	0.6 Dc	-	~0.15 Dc	~0.2	0.4 - 1.0 Dc
Heat Resistant Alloy	Grade	JC8118 (JC8050)	-	JC7518	JC7518	JC7518
	Vc	20 - 30	-	25 - 30	30 - 50	15 - 30
	fz	0.3	-	0.11 - 0.15	0.15 - 0.25	0.1 - 0.12
	ap	0.2 - 0.8	-	~5.0	~5.0	~0.2
	ae	0.6 Dc	-	~0.15 Dc	~0.20	0.4 - 1.0 Dc
Aluminium	Grade	-	-	FC18	FC18	FC18
	Vc	-	-	300 - 600	420 - 700	300 - 600
	fz	-	-	0.16 - 0.2	0.18 - 0.30	0.1 - 0.15
	ap	-	-	~5.0	~5.0	~0.3
	ae	-	-	~0.4 Dc	~0.3	0.4 - 1.0 Dc

QM MAX

MQX/QXP Type

■ Recommended Cutting Conditions

Material		Contouring	Side Finishing	Bottom Finishing	Vertical Side Finishing	Side Finishing	Bottom Finishing	Vertical Side Finishing
		YPHW-24	YPHW-15			YPHW-F (CBN)		
Carbon Steel below 250HB	Grade	-	JC8015 (DH102)	DH102	JC8015 (DH102)	-	-	-
	Vc	-	450 - 650	170 - 260	350 - 450	-	-	-
	fz	-	0.1 - 0.15	0.18 - 0.25	0.08 - 0.18	-	-	-
	ap	-	0.7 - 2.0	~0.2	Pf 0.5 - 1.12	-	-	-
	ae	-	~0.2	~0.6 Dc	~0.2	-	-	-
Tool & Die Steel below 255HB	Grade	-	JC8015 (DH102)	DH102	JC8015 (DH102)	-	-	-
	Vc	-	350 - 450	150 - 240	300 - 400	-	-	-
	fz	-	0.1 - 0.15	0.18 - 0.25	0.08 - 0.18	-	-	-
	ap	-	0.7 - 2.0	~0.2	Pf 0.5 - 1.12	-	-	-
	ae	-	~0.2	~0.6 Dc	~0.2	-	-	-
Mold Steel 30-36HRC	Grade	-	JC8015 (DH102)	DH102	JC8015 (DH102)	-	-	-
	Vc	-	350 - 450	140 - 220	250 - 350	-	-	-
	fz	-	0.1 - 0.15	0.17 - 0.2	0.07 - 0.15	-	-	-
	ap	-	0.7 - 2.0	~0.2	Pf 0.5 - 1.12	-	-	-
	ae	-	~0.2	~0.6 Dc	~0.2	-	-	-
Mold Steel 38-43HRC	Grade	JC8015 (DH102)	JC8015 (DH102)	DH102	JC8015 (DH102)	-	-	-
	Vc	220	350 - 400	150 - 200	180 - 250	-	-	-
	fz	0.25	0.08 - 0.12	0.1 - 0.12	0.07 - 0.12	-	-	-
	ap	0.15 - 0.4	0.7 - 2.0	~0.2	Pf 0.5 - 1.12	-	-	-
	ae	~0.4 Dc	~0.2	~0.6 Dc	~0.2	-	-	-
Hardened Die Steel 42-52HRC	Grade	JC8015 (DH102)	JC8015 (DH102)	DH102	DH102 (JC8015)	JBN795	JBN795	JBN795
	Vc	160	170 - 200	60 - 100	120 - 170	400 - 450	300 - 350	400 - 450
	fz	0.25	0.08 - 0.1	0.1	0.06 - 0.1	0.07 - 0.08	0.06 - 0.08	0.07 - 0.08
	ap	0.1 - 0.25	~1.5	~0.2	Pf 0.5 - 1.12	~1.2	~0.08	Pf 0.5 - 1.12
	ae	~0.4 Dc	~0.2	~0.6 Dc	~0.15	~0.1	~0.6 Dc	~0.1
Hardened Die Steel 55-62HRC	Grade	DH102	DH102	DH102	-	JBN795	JBN795	-
	Vc	100	150 - 180	50 - 70	-	300 - 400	200	-
	fz	0.2	0.08 - 0.1	0.05 - 0.07	-	0.06 - 0.08	0.05 - 0.06	-
	ap	0.1 - 0.2	~1.0	~0.2	-	~1.2	~0.06	-
	ae	~0.3 Dc	~0.2	~0.4 Dc	-	~0.1	~0.6 Dc	-
Grey Cast Iron	Grade	-	JC8015 (DH102)	DH102	JC8015 (DH102)	JBN795	JBN795	JBN795
	Vc	-	450 - 550	130 - 200	450 - 550	750	700	750
	fz	-	0.1 - 0.15	0.1 - 0.2	0.1 - 0.15	0.1 - 0.135	0.1 - 0.12	0.1 - 0.135
	ap	-	0.7 - 2.0	~0.2	Pf 0.5 - 1.12	~1.5	~0.1	Pf 0.5 - 1.12
	ae	-	~0.2	~0.6 Dc	~0.2	~0.1	~0.6 Dc	~0.1
Nodular Cast Iron	Grade	-	JC8015 (DH102)	DH102	JC8015 (DH102)	JBN795	-	JBN795
	Vc	-	450 - 550	130 - 200	450 - 550	700	-	700
	fz	-	0.1 - 0.15	0.1 - 0.2	0.1 - 0.15	0.1 - 0.135	-	0.1 - 0.135
	ap	-	0.7 - 2.0	~0.2	Pf 0.5 - 1.12	~1.5	-	Pf 0.5
	ae	-	~0.2	~0.6 Dc	~0.2	~0.1	-	~0.1
Stainless Steel	Grade	-	JC8015 (DH102)	JC8015 (DH102)	-	-	-	-
	Vc	-	350 - 450	130 - 180	-	-	-	-
	fz	-	0.1 - 0.15	0.1 - 0.15	-	-	-	-
	ap	-	0.7 - 2.0	~0.2	-	-	-	-
	ae	-	~0.2	~0.6 Dc	-	-	-	-
Titanium Alloy	Grade	-	JC8015 (DH102)	DH102	-	-	-	-
	Vc	-	70 - 90	30 - 50	-	-	-	-
	fz	-	0.08 - 0.12	0.1 - 0.15	-	-	-	-
	ap	-	0.7 - 2.0	~0.2	-	-	-	-
	ae	-	~0.2	~0.6 Dc	-	-	-	-

Note

1. Please adjust cutting conditions according to machine rigidity or work rigidity.
2. In case of chatter occurring, recommended to reduce ap or rpm and keep feed per tooth.
3. ap should be reduced when using on low rigidity machine.
4. Use air blow.
5. When using Endmill type, reduce cutting conditions by 10-20%.

QM MILL **MPM/PME Type**

Low cutting force geometry

- Unique 3D geometry insert provides stable cutting and less power consumption.
- BT30 Capable of running on low horse power & compact machines.



Multi - flutes specification

- High speed and high efficient machining.

Vibration free

- Control vibration with combination of MSN carbide shank holder for longer tool life.



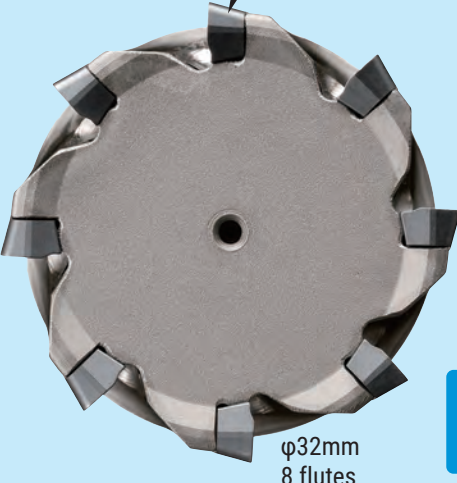
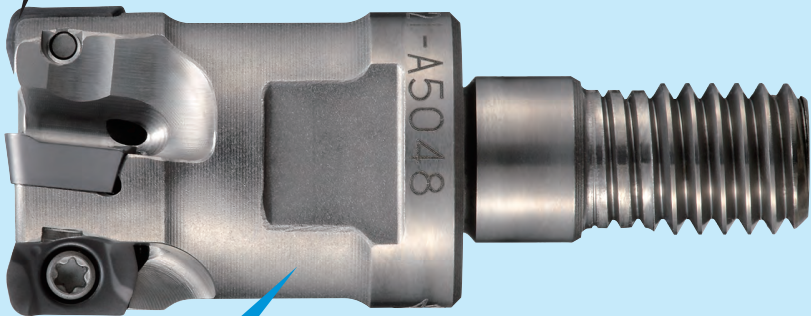

Low cutting force geometry **High feed machining with Multi-flutes specification**

Adopted G-Body **Possible to use even for finishing applications**

Insert Line-Up

A variety of inserts all fit into the same body.

<p>High feed insert</p>  <p style="text-align: center;">EOMT0602...ZER (R1.0, 2.0)</p>	<p>High feed insert for unfavorable conditions</p>  <p style="text-align: center;">EOMW060210ZER</p>	
<p>Shoulder insert</p>  <p style="text-align: center;">ZOMT0602...ZER-PL (R0.2,0.4,0.8)</p>	<p>For high hardened steel</p>  <p style="text-align: center;">EOHW0602...ZTR (R1.0, 2.0)</p>	<p>"Mirror Insert" for finishing side & bottom face</p>  <p style="text-align: center;">YOHW0602...ZER-12</p>

QM MILL **MPM/PME Type**

PME
TYPE

Shank Type



■ **PME type (Through coolant hole)**

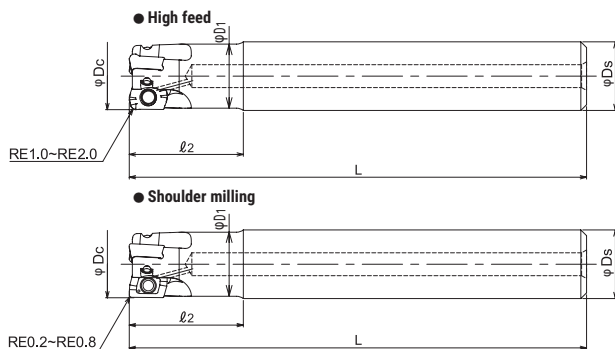

■ **PME-LS type (No coolant hole)**

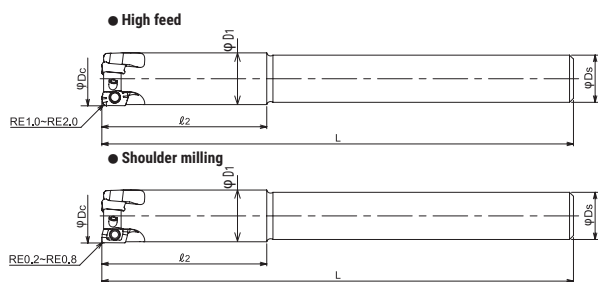

Type	Cat.No.	Stock	No. of inserts	Dimensions (mm)					Insert
				φD_c	ℓ_2	L	φD_1	φD_s	
Standard	PME2010S10	●	2	10	20	80	9.3	10	EO**0602**Z*R ZOMT0602**ZER YOHWO602**ZER-12
	PME3012S12	●	3	12			11.2		
	PME3014S12	●		14			13.15		
Long shank	PME2011S10-LS	●	2	11	33	120	10.3	10	
	PME3013S12-LS	●	3	13			12.2		
	PME3014S12-LS	●		14			13.15		

Screw	Torque(N.m)	Wrench
DSW-1840H	0.4	A-06

QM MILL **MPM/PME Type**

MPM
TYPE

Modular Type

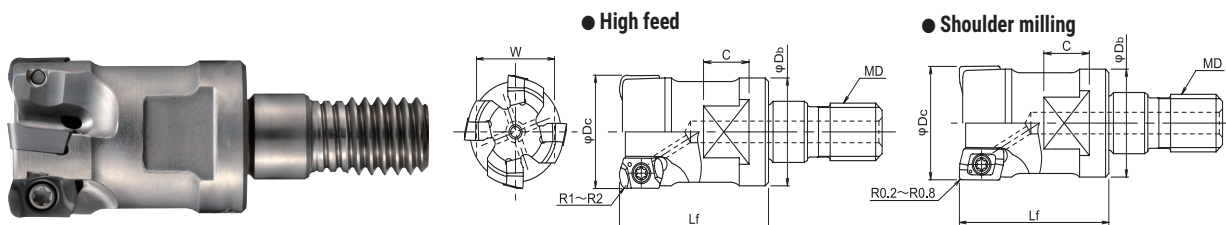

Cat.No.	Stock	No. of inserts	Dimensions (mm)						Insert
			φDc	Lf	φDb	MD	C	W	
MPM-2010-M6	●	2	10	18	9.5	M6	6.5	8	EO**0602**Z*R ZOMT0602**ZER YOHW0602**ZER-12
MPM-2011-M6	●		11		9.7				
MPM-3012-M6	●	3	12	20	11.2	M6	8		
MPM-3013-M6	●		13		11.5				
MPM-3015-M8	○	4	15	23	14	M8	12		
MPM-4016-M8	●		16		15				
MPM-4017-M8	●	5	17	30	19	M8	14		
MPM-4018-M8	○		18					M8	
MPM-5020-M10	●	6	20	35	23.6	M10	17		
MPM-5021-M10	●		21					M10	
MPM-6025-M12	●	7	25	43	29	M12	22		
MPM-7030-M16	●		30					M16	
MPM-8032-M16	●	8	32	M16					

MPT
TYPE

High Precision "QM MILL"

High tolerance insert-pocket for the ground inserts

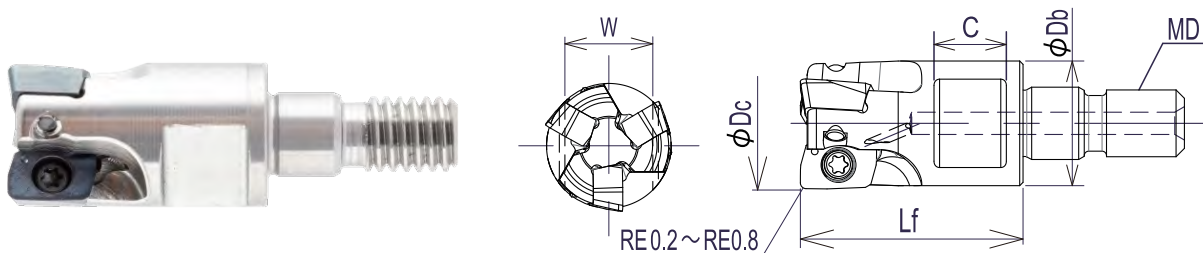

Cat.No.	Stock	No. of inserts	Dimensions (mm)						Insert
			φDc	Lf	φDb	MD	C	W	
MPT-2010A00-M6	●	2	10	18	9.5	M6	6.5	8	ZOMT0602**ZER YOHW0602**ZER-12
MPT-2011A00-M6	○		11		9.7				
MPT-3012A00-M6	●	3	12	20	11.2	M6	8		
MPT-3013A00-M6	○		13		11.5				
MPT-4016A00-M8	●	4	16	23	15	M8	12		

Screw	Torque(N.m)	Wrench
DSW-1840H	0.4	A-06

QM MILL **MPM/PME Type**

Insert

High feed insert

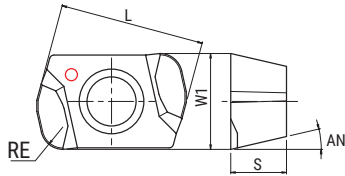

For high hardened steel

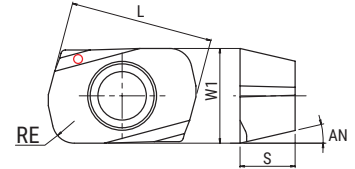
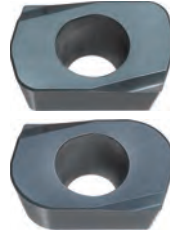

Shoulder insert

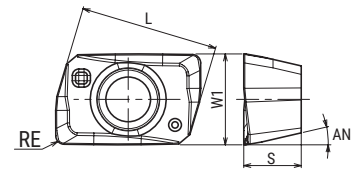

High feed insert for unfavorable conditions

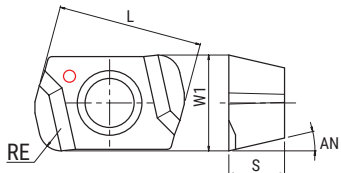

"Mirror Insert" for finishing side & bottom face

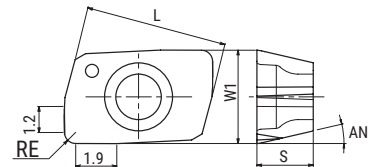

Type	Cat.No.	Tolerance	PVD Coating						Dimensions (mm)				
			DH102	DS118	DS150	JC7560	JC8015	JC8050	JC8118	RE	L	W1	S
High feed insert	EOMT060210ZER	M		●	●	●		●	●	1	6.5	2.5	13°
	EOMT060220ZER			●	●			●	●	2			
High feed insert for unfavorable conditions	EOMW060210ZER				●			●	●	1			
For high hardened steel	EOHW060210ZTR	H	●						●	●			
	EOHW060220ZTR		●							●	●	2	
shoulder insert	ZOMT060202ZER-PL	M						●	●	0.2	6.62	4.3	2.7
	ZOMT060204ZER-PL							●	●	0.4			
	ZOMT060208ZER-PL								●	●			
"Mirror Insert" for finishing side & bottom face	YOHW060203ZER-12	H	●							0.3	6.5	2.6	
	YOHW060205ZER-12		●				●			0.5			
	YOHW060208ZER-12		●							0.8			
							●						

GRADE MARKINGS

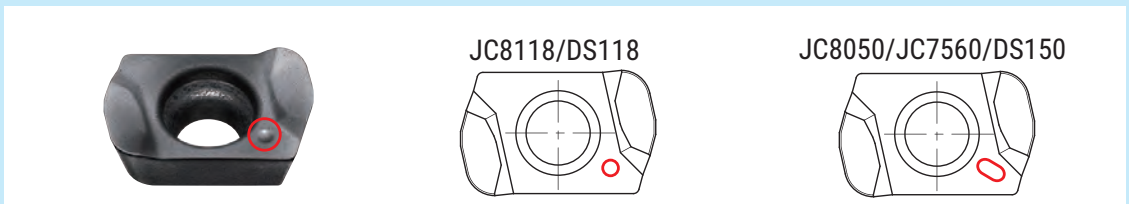

MAGNETIZER



- Magnetizing and demagnetizing a wrench can easily be done by inserting the tip into the magnetizer and rubbing lightly.
- Do not use in the vicinity of the equipment that can be influenced with magnetism.

Cat.No.	Stock
MAGNETISER	●

QM MILL

MPM/PME Type

■ Insert selection guide

Material	Carbon steel (S50C, S55C) below 250HB						Tool & die steel # (SKD61, SKD11) below 255HB							
	Cat.No.	Grade	JC8118	JC8050	JC7560	DH102	DS118	DS150	JC8118	JC8050	JC7560	DH102	DS118	DS150
EOMT0602*0ZER			☆	☆	☆				☆	☆	☆			
EOMW060210ZER			○	○	◎				○	○	◎			
EOHW0602*0ZTR														

Material	Mold steel (HPM7, PX5, KPM30) 30-36HRC						Mold steel (NAK80, HPM1) 38-43HRC							
	Cat.No.	Grade	JC8118	JC8050	JC7560	DH102	DS118	DS150	JC8118	JC8050	JC7560	DH102	DS118	DS150
EOMT0602*0ZER			☆	☆	☆				☆	☆				
EOMW060210ZER			○	○	◎				◎	○				
EOHW0602*0ZTR														

Material	Hardened die steel (SKD61, DAC, DHA) 42-52HRC						Hardened die steel (SKD11, SLD, DC11) 55-62HRC							
	Cat.No.	Grade	JC8118	JC8050	JC7560	DH102	DS118	DS150	JC8118	JC8050	JC7560	DH102	DS118	DS150
EOMT0602*0ZER			☆						x	x				
EOMW060210ZER			○	●					○					
EOHW0602*0ZTR			◎						●			◎		

Material	Cast iron (FC, FCD) below 300HB						Stainless steel (SUS304) below 250HB							
	Cat.No.	Grade	JC8118	JC8050	JC7560	DH102	DS118	DS150	JC8118	JC8050	JC7560	DH102	DS118	DS150
EOMT0602*0ZER			○							◎	○			
EOMW060210ZER			◎		●					●				
EOHW0602*0ZTR														

Material	Titanium alloy (Ti-6Al-4V)						Heat resistant alloy (INCO718)							
	Cat.No.	Grade	JC8118	JC8050	JC7560	DH102	DS118	DS150	JC8118	JC8050	JC7560	DH102	DS118	DS150
EOMT0602*0ZER			○	○	◎		○	◎	◎	○	○		○	○
EOMW060210ZER					●					●				
EOHW0602*0ZTR														

◎: First choice ○: For general milling ●: For unstable milling ☆: For light cutting force x: Not recommended

QM MILL

MPM/PME Type

Definition of corner shape for programming

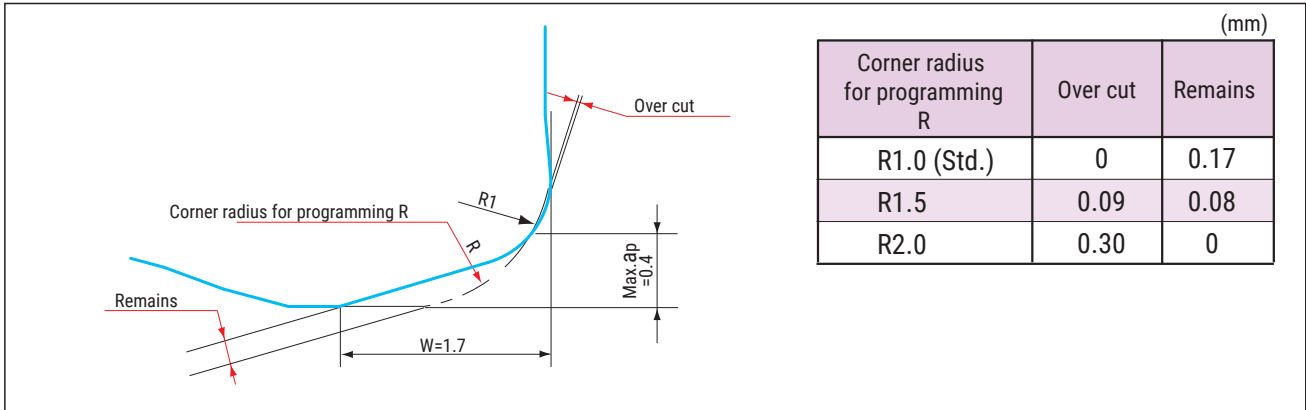

Recommended Data for Profile Milling

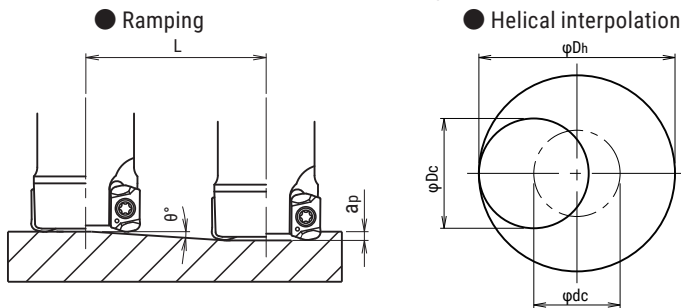

- Calculation of tool pass dia.

$$\phi_{dc} = \phi_{Dh} - \phi_{Dc}$$

Tool pass dia. Bore dia. Tool Dia.

- Depth of cut per one circuit should not exceed max. depth of cut a_p
- Down cutting is recommended, tool pass rotation should be counterclockwise

- In case of ramping and helical interpolation, apply 70% or less feed (V_f) from standard cutting condition table
- In case of drilling, apply 50% or less Z axis feed (F) from standard cutting condition table
- Long consecutive chips may result in case of drilling, confirm safe operating conditions

Cat.No.	Tool dia. (mm)	Effective cutting dia. (mm)	Max.depth of cut: a_p (mm)	Ramping		Helical interpolation	
				Max. ramping angle θ	Max. depth of cut (a_p) Total cutting length L(mm)	Min. Bore dia. (mm)	Max. Bore dia. (mm)
MPM-2010-M6	10	6.6	0.3	2°18'	7.5	15	18
MPM-2011-M6	11	7.6	0.3	1°54'	9	17	20
MPM-3012-M6	12	8.5	0.3	1°36'	10.7	19	22
MPM-3013-M6	13	9.5	0.3	1°24'	12.3	21	24
MPM-3015-M8	15	11.5	0.4	1°12'	19.1	25	28
MPM-4016-M8	16	12.5	0.4	1°	22.9	27	30
MPM-4017-M8	17	13.5	0.4	0°54'	25.5	29	32
MPM-4018-M8	18	14.5	0.4	0°51'	27.0	31	34
MPM-5020-M10	20	16.5	0.4	0°45'	30.6	35	38
MPM-5021-M10	21	17.5	0.4	0°42'	32.7	37	40
MPM-6025-M12	25	21.5	0.4	0°30'	45.8	45	48
MPM-7030-M16	30	26.5	0.4	0°27'	50.9	55	58
MPM-8032-M16	32	28.5	0.4	0°24'	57.3	59	62
PME2010S10	10	6.6	0.3	2°18'	7.5	15	18
PME2011S10-LS	11	7.6	0.3	1°54'	9	17	20
PME3012S12	12	8.5	0.3	1°36'	10.7	19	22
PME3013S12-LS	13	9.5	0.3	1°24'	12.3	21	24
PME3014S12 (-LS)	14	10.5	0.3	1°18'	13.2	23	26

QM MILL

MPM Type

Recommended Cutting Conditions

Material		High Feed		Side Finishing	Bottom Finishing
		EOMT / EOMW	EOHW	YOHW	YOHW
Carbon Steel below 250HB	Grade	JC7560 (JC8050 JC8118)	-	JC8015 (DH102)	JC8015 (DH102)
	Vc	95 - 120	-	280 - 400	160 - 250
	fz	0.5 - 0.9	-	0.1 - 0.15	0.14 - 0.2
	ap	0.2 - 0.4	-	~1.2	~0.12
	ae	0.7 Dc	-	~0.1	0.6 Dc
Tool & Die Steel below 255HB	Grade	JC7560 (JC8050 JC8118)	-	JC8015 (DH102)	JC8015 (DH102)
	Vc	90 - 110	-	250 - 360	150 - 230
	fz	0.5 - 0.9	-	0.1 - 0.15	0.13 - 0.18
	ap	0.15 - 0.4	-	~1.0	~0.12
	ae	0.7 Dc	-	~0.1	0.6 Dc
Mold Steel 30-36HRC	Grade	JC8118 (JC7560 JC8050)	-	JC8015 (DH102)	JC8015 (DH102)
	Vc	90 - 110	-	250 - 360	150 - 230
	fz	0.5 - 0.9	-	0.1 - 0.15	0.13 - 0.18
	ap	0.2 - 0.4	-	~1.0	~0.12
	ae	0.7 Dc	-	~0.1	0.6 Dc
Mold Steel 38-43HRC	Grade	JC8118 (JC8050)	-	DH102 (JC8015)	DH102 (JC8015)
	Vc	70 - 90	-	200 - 280	130 - 200
	fz	0.5 - 0.7	-	0.08 - 0.12	0.08 - 0.12
	ap	0.2 - 0.3	-	~1.0	~0.12
	ae	0.6 Dc	-	~0.1	0.6 Dc
Hardened Die Steel 42-52HRC	Grade	JC8118	JC8118	DH102 (JC8015)	DH102 (JC8015)
	Vc	50 - 70	70 - 90	140 - 200	90 - 120
	fz	0.45 - 0.6	0.3 - 0.6	0.08 - 0.1	0.08 - 0.1
	ap	0.15 - 0.3	0.1 - 0.25	~0.8	~0.1
	ae	0.6 Dc	0.6 Dc	~0.1	0.4 Dc
Hardened Die Steel 55-62HRC	Grade	-	DH102	DH102	DH102
	Vc	-	70 - 80	100 - 150	50 - 70
	fz	-	0.27 - 0.3	0.08 - 0.1	0.06 - 0.08
	ap	-	0.1 - 0.15	~0.5	~0.1
	ae	-	0.4 Dc	~0.1	0.4 Dc
Grey & Nodular Cast Iron below 300HB	Grade	JC8118	-	JC8015 (DH102)	JC8015 (DH102)
	Vc	120 - 150	-	280 - 400	130 - 200
	fz	0.5 - 0.9	-	0.1 - 0.15	0.1 - 0.15
	ap	0.2 - 0.4	-	~1.2	~0.15
	ae	0.7 Dc	-	~0.12	0.6 Dc
Stainless Steel	Grade	JC8050 (JC7560)	-	JC8015 (DH102)	JC8015 (DH102)
	Vc	95 - 120	-	250 - 360	150 - 230
	fz	0.5 - 0.9	-	0.1 - 0.15	0.13 - 0.18
	ap	0.15 - 0.4	-	~1.0	~0.12
	ae	0.6 Dc	-	~0.1	0.6 Dc
Titanium Alloy	Grade	DS150 (JC7560 JC8050 DS118)	-	JC8015 (DH102)	JC8015 (DH102)
	Vc	50 - 60	-	55 - 80	30 - 50
	fz	0.4 - 0.5	-	0.08 - 0.12	0.09 - 0.12
	ap	0.15 - 0.3	-	~1.0	~0.12
	ae	0.6 Dc	-	~0.1	0.6 Dc
Heat Resistant Alloy	Grade	JC8118 (JC8050)	-	-	-
	Vc	25 - 30	-	-	-
	fz	0.3 - 0.4	-	-	-
	ap	0.15 - 0.3	-	-	-
	ae	0.6 Dc	-	-	-

Note

1. Please adjust cutting conditions according to machine rigidity or work rigidity.
2. In case of chatter occurring, recommended to reduce ap or rpm and keep feed per tooth.
3. ap should be reduced when using on low rigidity machine.
4. Use air blow.

■ Recommended Cutting Conditions

Material		Shoulder Milling	Side Finishing	Bottom Finishing
		ZOMT	ZOMT	ZOMT
Carbon Steel below 250HB	Grade	JC8050 (JC8118)	JC8050 (JC8118)	JC8050 (JC8118)
	Vc	128 - 160	145 - 240	90 - 180
	fz	0.06 - 0.08	0.07 - 0.13	0.1 - 0.15
	ap	~4.0	~4.0	~0.15
	ae	~0.15 Dc	~0.1	~0.6 Dc
Tool & Die Steel below 255HB	Grade	JC8050 (JC8118)	JC8050 (JC8118)	JC8050 (JC8118)
	Vc	120 - 150	130 - 215	80 - 160
	fz	0.04 - 0.06	0.07 - 0.13	0.1 - 0.15
	ap	~4.0	~4.0	~0.15
	ae	~0.15 Dc	~0.1	~0.6 Dc
Mold Steel 30-36HRC	Grade	JC8118 (JC8050)	JC8118 (JC8050)	JC8118 (JC8050)
	Vc	120 - 150	130 - 215	80 - 160
	fz	0.03 - 0.05	0.07 - 0.13	0.1 - 0.15
	ap	~4.0	~4.0	~0.15
	ae	~0.15 Dc	~0.1	~0.6 Dc
Mold Steel 38-43HRC	Grade	JC8118 (JC8050)	JC8118 (JC8050)	JC8118 (JC8050)
	Vc	90 - 120	110 - 185	70 - 140
	fz	0.03 - 0.05	0.05 - 0.1	0.1 - 0.15
	ap	~3.0	~3.0	~0.15
	ae	~0.13 Dc	~0.1	~0.6 Dc
Hardened Die Steel 42-52HRC	Grade	JC8118	JC8118	JC8118
	Vc	80 - 100	90 - 120	75 - 100
	fz	0.03 - 0.05	0.05 - 0.07	0.1 - 0.12
	ap	~2.5	~2.5	~0.1
	ae	~0.12 Dc	~0.1	~0.6 Dc
Grey & Nodular Cast Iron below 300HB	Grade	JC8118	JC8118	JC8118
	Vc	120 - 150	125 - 210	90 - 180
	fz	0.06 - 0.08	0.07 - 0.15	0.12 - 0.18
	ap	~4.0	~4.0	~0.15
	ae	~0.15 Dc	~0.1	~0.6 Dc
Stainless Steel	Grade	JC8050	JC8050	JC8050
	Vc	120 - 150	130 - 215	80 - 160
	fz	0.04 - 0.06	0.07 - 0.13	0.1 - 0.15
	ap	~4.0	~4.0	~0.15
	ae	~0.15 Dc	~0.1	~0.6 Dc

Note

1. Please adjust cutting conditions according to machine rigidity or work rigidity.
2. In case of chatter occurring, recommended to reduce ap or rpm and keep feed per tooth.
3. ap should be reduced when using on low rigidity machine.
4. Use air blow.

EXTREME SAP

EXSAP/MSX Type

EXTREME SAP

EXSAP/MSX TYPE



Facemill type

Modular head type

Shank type

Various line up

Capable of a variety of applications such as facemilling, slotting and plunging

Arc-shaped cutting edge trajectory

Due to the arc-geometry on peripheral cutting edge, cusp height can be smaller even in case of large ap.

Achieves high efficient & high precision machining for side walls.

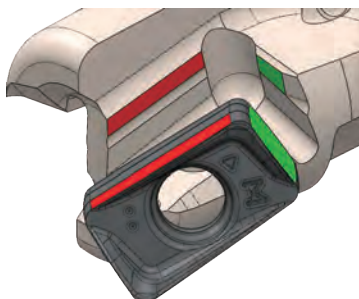

Strong clamping system

Due to unique clamping system that holds insert in place, it is possible to achieve high efficient machining in roughing application.

High precision G class periphery ground

capable of semi-finishing



Double sided 4 cutting edge insert

EXTREME SAP **EXSAP/MSX Type**

■ **EXSAP-11 type**



High speed machining
with multi flutes & small insert

Accuracy of tool diameter : 0-0.1mm
Achieves higher precision on semi-finishing process

Grade: **JC8050**
JC8118

PM breaker for general steel (up to 50HRC)

Grade: **JC7550**
JC7518
DS118
DS150

SL breaker for hard to cut material
such as Titanium alloy, Heat resistant alloy

■ **EXSAP-17 type**



Max.depth of cut (ap)=15mm
From roughing to semi-finishing

High rigidity insert
Achieves high precision machining even when using large ap

Grade: **JC8050**
JC8118

PM breaker for general steel (up to 50HRC)

■ **Insert grades**

ISO	P					M					K				S				
	P01	P10	P20	P30	P40	M01	M10	M20	M30	M40	K01	K10	K20	K30	S01	S10	S20	S30	
Range			JC8118					JC8118					JC8118				DS118		
				JC8050					JC8050								DS150		
			JC7518					JC7518									JC7518		
				JC7550					JC7550									JC7550	

EXTREME SAP **EXSAP/MSX Type**

EXSAP-11
TYPE

Bore Type

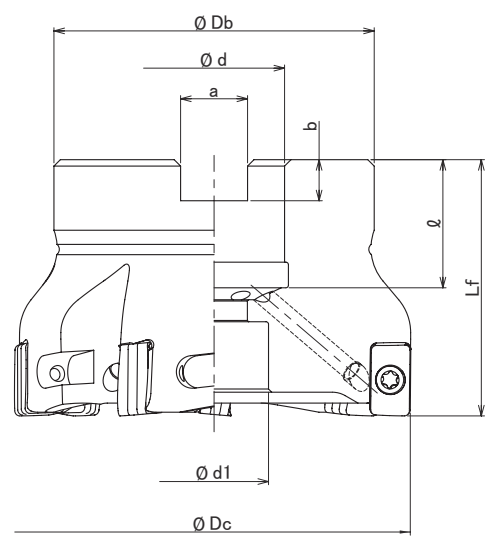

Cat.No.	Stock	No. of inserts	Dimensions (mm)								Arbor set bolt	Weight (kg)	Inserts
			$\varnothing Dc$	Lf	$\varnothing Db$	$\varnothing d$	$\varnothing d1$	a	b	ℓ			
EXSAP-6040R-11-16	●	6	40	40	35	16	14	8.4	5.6	18	M8	0.22	ZNGU1105**ZER-**
EXSAP-7050R-11-22	●	7	50		47	22	16.5	10.4	6.3	20	M10	0.38	
EXSAP-7052R-11-22	●		52		50	22	17	10.4	6.3	20	M10	0.39	
EXSAP-7063R-11-22	●		63	M10							0.53		
EXSAP-7063R-11-27	●		8	80	50	27	20	12.4	7	22	M12X1.75X30*	0.62	
EXSAP-8080R-11-27	●	56			M12X1.75X30*						0.99		

Screw	Torque(N.m)	Wrench
TSW-307H	2.1	A-10

EXTREME SAP **EXSAP/MSX Type**

EXSAP-11
TYPE

Shank Type

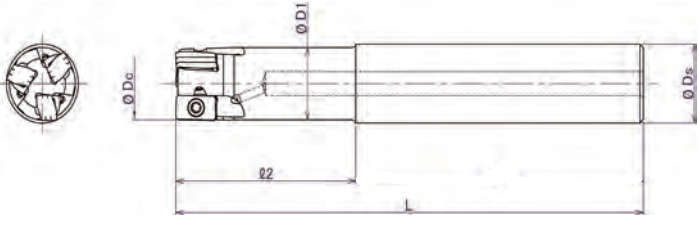
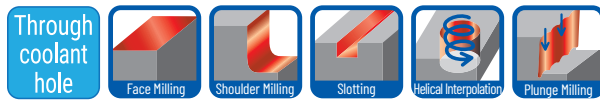

Cat.No.	Stock	No. of inserts	Dimensions (mm)					Insert
			φDc	ℓ2	L	φD1	φDs	
EXSAP-2016-11-50-S16+A	●	2	16	50	110	14.6	16	ZNGU1105**ZER**
EXSAP-3020-11-50-S20	●	3	20	50	130	18.3	20	
EXSAP-3025-11-50-S25+A	●	2	25	50	130	23.4	25	
EXSAP-4032-11-70-S32	●	4	32	70	150	29	32	

Note) +A types has no coolant holes.

Screw	Torque(N.m)	Wrench
TSW-307H	2.1	A-10

EXTREME SAP

EXSAP/MSX Type

MSX-11
TYPE

Modular Type

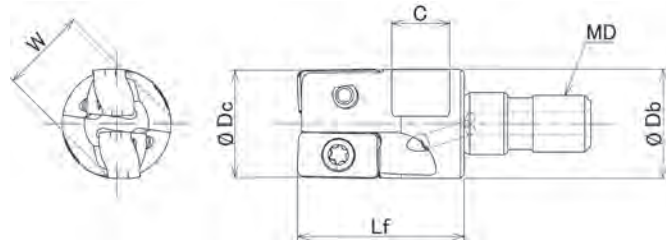
Through
coolant
hole

Cat.No.	Stock	No. of inserts	Dimensions (mm)						Insert
			φD_c	Lf	φD_b	MD	C	W	
MSX-2016-11-M8	●	2	16	23	15	M8	8	12	ZNGU1105**ZER**
MSX-2017-11-M8	○		17						
MSX-2018-11-M8	○		18						
MSX-3020-11-M10	●	3	20	30	18	M10	9	14	
MSX-3021-11-M10	○		21						
MSX-3025-11-M12	●		25						
MSX-3026-11-M12	○		26						
MSX-3028-11-M12	○	4	28	43	29	M16	12	22	
MSX-4030-11-M16	○		30						
MSX-4032-11-M16	●		32						
MSX-4033-11-M16	○		33						
MSX-4035-11-M16	○		35						
MSX-5040-11-M16	●	5	40						

Screw	Torque(N.m)	Wrench
TSW-307H	2.1	A-10

Insert



Fig 1

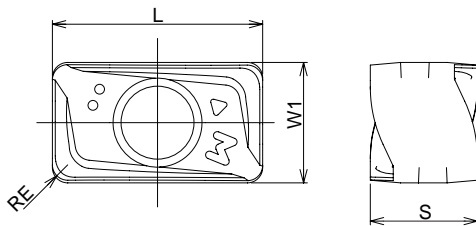
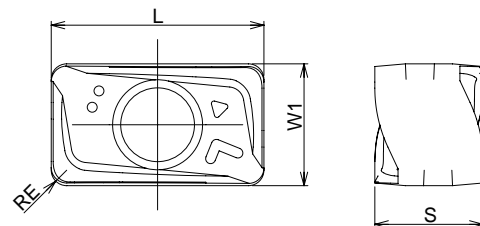
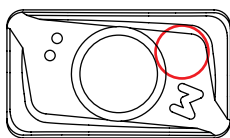

Fig 2



Cat.No.	Tolerance	PVD Coating						Dimensions (mm)				Fig.
		DS118	DS150	JC7518	JC7550	JC8050	JC8118	RE	L	W1	S	
ZNGU110504ZER-PM	G					●	●	0.4	11	6.3	5.6	1
ZNGU110508ZER-PM						●	●	0.8				
ZNGU110516ZER-PM						●	●	1.6				
ZNGU110504ZER-SL		●	●	●	●			0.4				2
ZNGU110508ZER-SL		●	●	●	●			0.8				
ZNGU110516ZER-SL		●	●	●	●			1.6				

Grade markings



JC8118

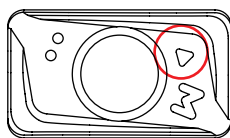

JC8050

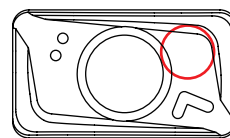

JC7518 / DS118

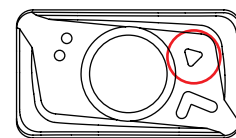

JC7550 / DS150

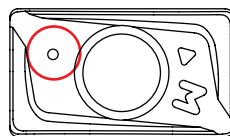

ZNGU110504ZER

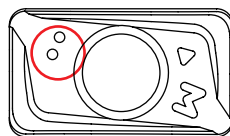

ZNGU110508ZER

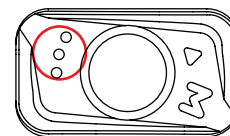

ZNGU110516ZER

EXTREME SAP **EXSAP/MSX Type**

EXSAP-17
TYPE

Bore Type

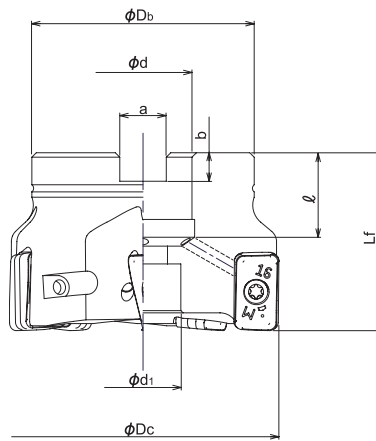

Cat.No.	Stock	No. of inserts	Dimensions (mm)								Arbor set bolt	Weight (kg)	Insert							
			φDc	Lf	φDb	φd	φd1	a	b	ℓ										
EXSAP-4050R-22	●	4	50	40	47	22	17	10.4	6.3	20	M10	0.38	ZNGU1709**ZER-PM							
EXSAP-5050R-22	●	5	52									50		56	27	20	12.4	7	22	0.38
EXSAP-5052R-22	●		63	85	32	26	14.4	8	25	M16X2X25*										0.41
EXSAP-5063R-22	●		80																	100
EXSAP-7080R-27	●	7	100	125	63	100	40	32	16.4	9	32	M20X2.5X40*								
EXSAP-7100R-32	●	8	63											100	40	32	16.4	9	32	M20X2.5X40*
EXSAP-8125R-40	●	8	125	100	40	32	16.4	9	32	M20X2.5X40*	3.66									

Screw	Torque(N.m)	Wrench
TSW-410H	3.5	A-15T

EXTREME SAP **EXSAP/MSX Type**

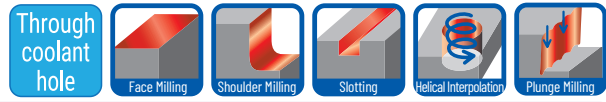

EXSAP-17
TYPE

Shank Type

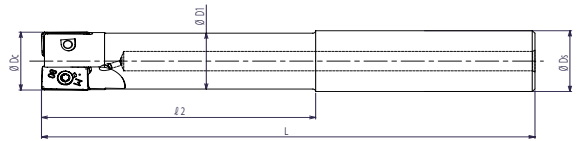

Cat.No.	Stock	No. of inserts	Dimensions (mm)					Insert
			φDc	ℓ2	L	φD1	φDs	
EXSAP-2025-60-S25	●	2	25	60	140	23	25	ZNGU1709**ZER-PM
EXSAP-2025-100-S25	○			100	180			
EXSAP-2032-70-S32	○		70	150				
EXSAP-2032-120-S32	○	3	32	120	200	29	32	
EXSAP-3032-70-S32	●			70	150			
EXSAP-3032-120-S32	○		120	200				

Screw	Torque(N.m)	Wrench
TSW-410H	3.5	A-15

EXTREME SAP

EXSAP/MSX Type

MSX-17
TYPE

Modular Type

Through
coolant
holeG-
Body

Face Milling

Shoulder Milling

Slotting

Helical Interpolation

Plunge Milling

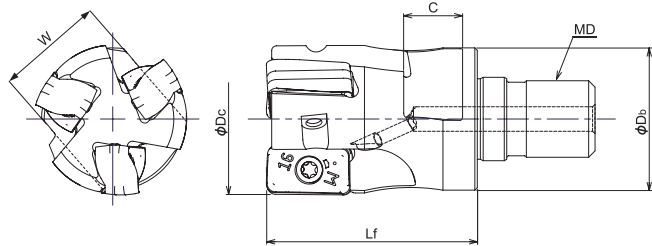

Cat.No.	Stock	No. of inserts	Dimensions (mm)						Insert
			ϕD_c	Lf	ϕD_b	MD	C	W	
MSX-2025-M12	●	2	25	35	22	M12	11	19	ZNGU1709**ZER-PM
MSX-2026-M12	○		26						
MSX-2028-M12	○		28						
MSX-2030-M16	○		30						
MSX-2032-M16	●	3	32	43	29	M16	12	22	
MSX-3032-M16	●		33						
MSX-3033-M16	○		35						
MSX-3035-M16	○		35						
MSX-4040-M16	●		40						

Screw	Torque(N.m)	Wrench
TSW-410H	3.5	A-15

Insert

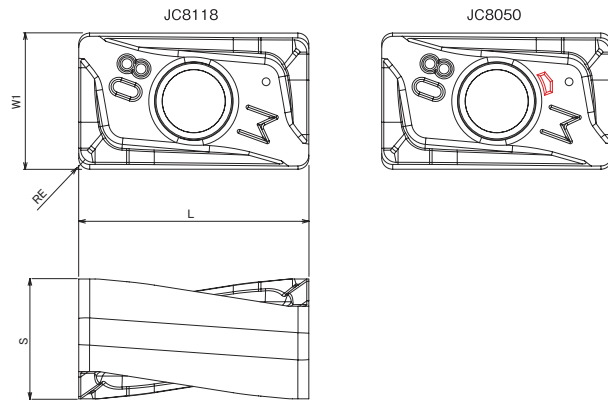

Cat.No.	Tolerance	PVD Coating		Dimensions (mm)			
		JC8050	JC8118	RE	L	W1	S
ZNGU170904ZER-PM	G	●	●	0.4	16.9	10	8.8
ZNGU170908ZER-PM		●	●	0.8			
ZNGU170916ZER-PM		●	●	1.6			
ZNGU170920ZER-PM		●	●	2			
ZNGU170930ZER-PM		●	●	3	8.6		

Cat.No.	Tolerance	PVD Coating	Dimensions (mm)			
		JC7550	RE	L	W1	S
ZNGU170908ZER-SM	G	●	0.8	16.9	10	8.8

EXTREME SAP

EXSAP/MSX Type

Recommended Data for Profile Milling

EXSAP-11 Type

Ramping

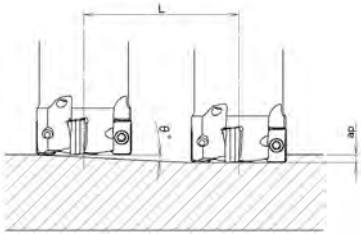

Helical interpolation

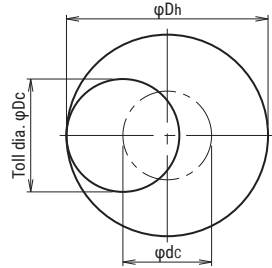

EXSAP-17 Type

Ramping

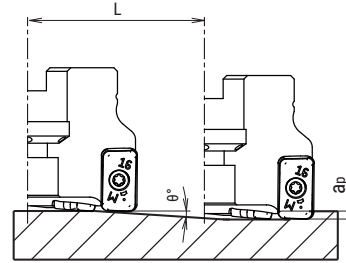

Helical interpolation

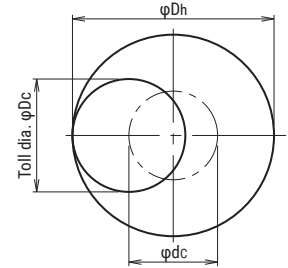

Cat. No.	Tool dia.	Effective Cutting dia.	Max. depth of cut : ap	Ramping		Helical interpolation	
				Max. ramping angle θ	Max. depth of cut : ap Total cutting length L(mm)	Min. Bore dia.	Max. Bore dia.
MSX-2016-11-M8	16	14.1	1.5	1.0°	86	18	29.6
MSX-3020-11-M10	20	18.1	1.5	0.7°	123	26	37.6
MSX-3025-11-M12	25	23.1	1.5	0.4°	215	36	47.6
MSX-4030-11-M16	30	28.1	1.5	0.3°	286	46	57.6
MSX-4032-11-M16	32	30.1	1.5	0.3°	286	50	61.6
MSX-5040-11-M16	40	38.1	1.5	0.2°	430	66	77.6
EXSAP-2016-11-**-S16	16	14.1	1.5	1.0°	86	18	29.6
EXSAP-3020-11-**-S20	20	18.1	1.5	0.7°	123	26	37.6
EXSAP-3025-11-**-S25	25	23.1	1.5	0.4°	215	36	47.6
EXSAP-4030-11-**-S32	30	28.1	1.5	0.3°	286	46	57.6
EXSAP-4032-11-**-S32	32	30.1	1.5	0.3°	286	50	61.6
EXSAP-5040-11-**-S32	40	38.1	1.5	0.2°	430	66	77.6
EXSAP-6040R-11-16	40	38.1	1.5	0.2°	430	66	77.6
EXSAP-7050R-11-22	50	48.1	1.5	0.15°	573	86	97.6
EXSAP-7052R-11-22	52	50.1	1.5	0.15°	573	90	101.6
EXSAP-7063R-11-22	63	61.1	1.5	Not recommended			
EXSAP-7063R-11-27	63	61.1	1.5	Not recommended			
EXSAP-8080R-11-27	80	78.1	1.5	Not recommended			

Cat. No.	Tool dia.	Effective Cutting dia.	Max. depth of cut : ap	Ramping		Helical interpolation	
				Max. ramping angle θ	Max. depth of cut : ap Total cutting length L(mm)	Min. Bore dia.	Max. Bore dia.
EXSAP/MSX-2025	25	21.5	1.5	0.7°	123	34	46
MSX-2026-M12	26	22.5	1.5	0.7°	123	36	48
MSX-2028-M12	28	25.5	1.5	0.6°	143	40	52
MSX-2030-M16	30	26.5	1.5	0.6°	143	44	56
EXSAP/MSX-*032	32	28.5	1.5	0.5°	172	48	60
MSX-3033-M16	33	29.5	1.5	0.5°	172	50	62
MSX-3035-M16	35	31.5	1.5	0.4°	215	54	66
MSX-4040-M16	40	36.5	1.5	0.4°	215	64	76
EXSAP-*050R-22	50	46.5	1.5	0.3°	286	84	96
EXSAP-5052R-22	52	48.5	1.5	0.3°	286	88	100
EXSAP-5063R-22	63	59.5	1.5	0.2°	430	110	122
EXSAP-7080R-27	80	76.5	1.5	0.15°	573	144	156
EXSAP-7100R-32	100	96.5	Not recommended				
EXSAP-8125R-40	125	121.5	Not recommended				

- In case of ramping and helical interpolation, apply 80% or less feed (Vf) from standard cutting condition table
- In case of helical interpolation, recommend wet cutting by coolant through the tool

- Calculation of tool pass dia.

$$\varphi_{Dc} = \varphi_{Dh} - \varphi_{Dc}$$

Tool pass dia. Bore dia. Tool Dia.

- Depth of cut per one circuit should not exceed max. depth of cut Ap
- Down cutting is recommended, tool pass rotation should be counterclockwise

EXTREME SAP

EXSAP/MSX Type

Recommended Cutting Conditions

EXSAP-11 type / Side Milling

Material	Grade	Vc	fz		Tool dia. (mm)							
					16	20	25	32	40	50	63	80
Carbon Steel below 250HB	JC8050 (JC8118)	140 - 180	0.14 - 0.20	ap	~5	~5	~6	~6	~7	~8	~9	~9
				ap x ae	~4	~5	~7.2	~9.8	~14	~24	~30	~36
Cast Steel below 285HB	JC8050 (JC8118)	140 - 180	0.14 - 0.20	ap	~5	~5	~6	~6	~7	~8	~9	~9
				ap x ae	~4	~5	~7.2	~9.8	~14	~24	~30	~36
Tool & Die Steel below 255HB	JC8050 (JC8118)	140 - 180	0.14 - 0.20	ap	~5	~5	~6	~6	~7	~8	~9	~9
				ap x ae	~4	~5	~7.2	~9.8	~14	~24	~30	~36
Mold Steel 30-36HRC	JC8118 (JC8050)	110 - 130	0.10 - 0.18	ap	~5	~5	~6	~6	~7	~8	~9	~9
				ap x ae	~4	~5	~7.2	~9.8	~14	~24	~30	~36
Mold Steel 38-43HRC	JC8118 (JC8050)	90 - 120	0.10 - 0.18	ap	~5	~5	~6	~6	~7	~8	~9	~9
				ap x ae	~3.4	~4	~6	~8	~10	~20	~24	~28
Hardened Die Steel 42-52HRC	JC8118	80 - 100	0.07 - 0.12	ap	~3	~3.5	~4	~4	~4.5	~6	~9	~9
				ap x ae	~1.6	~2	~3.2	~3.6	~4	~8	~9	~10
Grey Cast Iron below 160-260HB	JC8118 (JC8050)	160 - 200	0.14 - 0.20	ap	~5	~5	~6	~6	~7	~8	~9	~9
				ap x ae	~5	~6	~9.8	~12	~16	~28	~34	~40
Nodular Cast Iron below 170-300HB	JC8118 (JC8050)	140 - 180	0.12 - 0.20	ap	~5	~5	~6	~6	~7	~8	~9	~9
				ap x ae	~5	~6	~9.8	~12	~16	~28	~34	~40
Austenitic Stainless Steel	JC8050 (JC7550)	100 - 120	0.10 - 0.18	ap	~5	~5	~6	~6	~7	~8	~9	~9
				ap x ae	~4	~5	~7.2	~9.8	~14	~24	~30	~36
Martensitic Stainless Steel	JC8050 (JC7550)	100 - 140	0.10 - 0.18	ap	~5	~5	~6	~6	~7	~8	~9	~9
				ap x ae	~3.2	~5	~7.2	~9.8	~14	~24	~30	~36
Titanium Alloy	DS150 (JC7550)	50 - 70	0.11 - 0.13	ap	~5	~5	~6	~6	~7	~8	~9	~9
				ap x ae	~3.2	~4	~6	~8	~10	~20	~26	~30
Heat Resistant Alloy	JC7518 (JC8118)	20 - 30	0.08 - 0.10	ap	~5	~5	~6	~6	~7	~8	~9	~9
				ap x ae	~3.2	~4	~6	~8	~10	~20	~26	~30

Note

1. Please adjust cutting conditions according to machine rigidity or work rigidity.
2. In case of chatter occurring, recommended to reduce ap or rpm and keep feed per tooth.
3. ap should be reduced when using on low rigidity machine.
4. Use air blow.

EXTREME SAP

EXSAP/MSX Type

Recommended Cutting Conditions

EXSAP-11 type / Face Milling

Material	Grade	Vc	fz		Tool dia. (mm)							
					16	20	25	32	40	50	63	80
Carbon Steel below 250HB	JC8050 (JC8118)	130 - 180	0.11 - 0.2	ap	~1	~1.2	~1.2	~1.5	~1.8	~2	~2	~2
				ae	~10	~12	~15	~18	~24	~30	~30	~48
Cast Steel below 285HB	JC8050 (JC8118)	130 - 180	0.11 - 0.2	ap	~1	~1.2	~1.2	~1.5	~1.8	~2	~2	~2
				ae	~10	~12	~15	~18	~24	~30	~30	~48
Tool & Die Steel below 255HB	JC8050 (JC8118)	130 - 180	0.11 - 0.2	ap	~1	~1.2	~1.2	~1.5	~1.8	~2	~2	~2
				ae	~10	~12	~15	~18	~24	~30	~30	~48
Mold Steel 30-36HRC	JC8118 (JC8050)	110 - 130	0.1 - 0.18	ap	~1	~1.2	~1.2	~1.5	~1.8	~2	~2	~2
				ae	~10	~12	~15	~18	~24	~30	~30	~48
Mold Steel 38-43HRC	JC8118 (JC8050)	90 - 120	0.1 - 0.16	ap	~0.8	~1	~1	~1.2	~1.4	~1.8	~1.8	~1.8
				ae	~10	~12	~15	~18	~24	~30	~30	~48
Hardened Die Steel 42-52HRC	JC8118	80 - 100	0.08 - 0.12	ap	~0.4	~0.5	~0.5	~0.6	~0.8	~1	~1	~1
				ae	~8	~8	~10	~12	~16	~20	~25	~32
Grey Cast Iron below 160-260HB	JC8118 (JC8050)	160 - 200	0.11 - 0.2	ap	~1	~1.2	~1.2	~1.5	~1.8	~2	~2	~2
				ae	~10	~12	~15	~18	~24	~30	~30	~48
Nodular Cast Iron below 170-300HB	JC8118 (JC8050)	130 - 180	0.11 - 0.2	ap	~1	~1.2	~1.2	~1.5	~1.8	~2	~2	~2
				ae	~10	~12	~15	~18	~24	~30	~30	~48
Austenitic Stainless Steel	JC8050 (JC7550)	100 - 120	0.11 - 0.18	ap	~1	~1.2	~1.2	~1.5	~1.8	~2	~2	~2
				ae	~6	~8	~10	~12	~16	~20	~25	~32
Martensitic Stainless Steel	JC8050 (JC7550)	100 - 150	0.11 - 0.18	ap	~1	~1.2	~1.2	~1.5	~1.8	~2	~2	~2
				ae	~10	~12	~15	~18	~24	~30	~30	~48
Titanium Alloy	DS150 (JC7550)	50 - 70	0.08 - 0.12	ap	~0.8	~1	~1	~0.8	~1.4	~1.8	~1.8	~1.8
				ae	~6	~8	~10	~12	~16	~20	~25	~32
Heat Resistant Alloy	JC7518 (JC8118)	20 - 30	0.06 - 0.11	ap	~0.8	~1	~1	~0.8	~1.4	~1.8	~1.8	~1.8
				ae	~6	~8	~10	~12	~16	~20	~25	~32

Note

1. Please adjust cutting conditions according to machine rigidity or work rigidity.
2. In case of chatter occurring, recommended to reduce ap or rpm and keep feed per tooth.
3. ap should be reduced when using on low rigidity machine.
4. Use air blow.
5. When using for slot milling, apply 50% or less feed (Vf) from standard cutting condition.

EXTREME SAP

EXSAP/MSX Type

Recommended Cutting Conditions

EXSAP-17 type / Side Milling

Material	Grade	Vc	fz		Tool dia. (mm)								
					25	32	40	50	63	80	100	125	
Carbon Steel below 250HB	JC8050	150 - 200	0.2 - 0.35	ap	~10	~12	~15	~15	~15	~15	~15	~15	~15
				ap x ae	~15	~24	~30	~40	~45	~45	~45	~45	
Cast Steel below 285HB	JC8050	130 - 180	0.2 - 0.35	ap	~10	~12	~15	~15	~15	~15	~15	~15	~15
				ap x ae	~15	~24	~30	~40	~45	~45	~45	~45	
Tool & Die Steel below 255HB	JC8050	150 - 200	0.2 - 0.35	ap	~10	~12	~15	~15	~15	~15	~15	~15	~15
				ap x ae	~15	~24	~30	~40	~45	~45	~45	~45	
Mold Steel 30-36HRC	JC8118	110 - 150	0.2 - 0.35	ap	~10	~12	~15	~15	~15	~15	~15	~15	~15
				ap x ae	~15	~24	~30	~40	~45	~45	~45	~45	
Mold Steel 38-43HRC	JC8118	90 - 120	0.15 - 0.25	ap	~10	~12	~15	~15	~15	~15	~15	~15	~15
				ap x ae	~12	~18	~20	~30	~30	~30	~30	~30	
Hardened Die Steel 42-52HRC	JC8118	80 - 100	0.1 - 0.2	ap	~10	~12	~12	~15	~15	~15	~15	~15	~15
				ap x ae	~7	~8	~12	~18	~25	~25	~25	~25	
Grey Cast Iron below 160-260HB	JC8118	200 - 250	0.2 - 0.35	ap	~10	~12	~15	~15	~15	~15	~15	~15	~15
				ap x ae	~15	~24	~30	~40	~45	~45	~45	~45	
Nodular Cast Iron below 170-300HB	JC8118	110 - 150	0.15 - 0.3	ap	~10	~12	~15	~15	~15	~15	~15	~15	~15
				ap x ae	~15	~24	~30	~40	~45	~45	~45	~45	
Austenitic Stainless Steel	JC8050 (JC7550)	100 - 120	0.1 - 0.2	ap	~10	~12	~15	~15	~15	~15	~15	~15	~15
				ap x ae	~15	~24	~30	~40	~45	~45	~45	~45	
Martensitic Stainless Steel	JC8118	130 - 180	0.15 - 0.3	ap	~10	~12	~15	~15	~15	~15	~15	~15	~15
				ap x ae	~15	~24	~30	~40	~45	~45	~45	~45	

Note

1. Please adjust cutting conditions according to machine rigidity or work rigidity.
2. In case of chatter occurring, recommended to reduce ap or rpm and keep feed per tooth.
3. ap should be reduced when using on low rigidity machine.
4. Use air blow.

EXTREME SAP

EXSAP/MSX Type

Recommended Cutting Conditions

EXSAP-17 type / Face Milling

Material	Grade	Vc	fz		Tool dia. (mm)							
					25	32	40	50	63	80	100	125
Carbon Steel below 250HB	JC8050	110 - 150	0.20 - 0.30	ap	~3	~3.5	~3.5	~4	~4	~4	~4	~4
				ae	~25	~32	~40	~50	~63	~80	~100	~125
Cast Steel below 285HB	JC8050	110 - 150	0.20 - 0.30	ap	~3	~3.5	~3.5	~4	~4	~4	~4	~4
				ae	~25	~32	~40	~50	~63	~80	~100	~125
Tool & Die Steel below 255HB	JC8050	110 - 150	0.15 - 0.25	ap	~3	~3.5	~3.5	~4	~4	~4	~4	~4
				ae	~25	~32	~40	~50	~63	~80	~100	~125
Mold Steel 30-36HRC	JC8118	110 - 130	0.15 - 0.25	ap	~3	~3.5	~3.5	~4	~4	~4	~4	~4
				ae	~25	~32	~40	~50	~63	~80	~100	~125
Mold Steel 38-43HRC	JC8118	90 - 110	0.15 - 0.25	ap	~2	~2.5	~2.5	~3	~3	~3	~4	~4
				ae	~25	~32	~40	~50	~63	~80	~100	~125
Hardened Die Steel 42-52HRC	JC8118	70 - 90	0.10 - 0.20	ap	~1	~2	~2	~2.5	~2.5	~2.5	~4	~4
				ae	~20	~25	~32	~40	~55	~65	~80	~100
Grey Cast Iron below 160-260HB	JC8118	130 - 180	0.20 - 0.30	ap	~5	~5.5	~5.5	~6	~6	~6	~4	~4
				ae	~25	~32	~40	~50	~63	~80	~100	~125
Nodular Cast Iron below 170-300HB	JC8118	110 - 130	0.15 - 0.25	ap	~3	~3.5	~3.5	~4	~4	~4	~4	~4
				ae	~25	~32	~40	~50	~63	~80	~100	~125
Austenitic Stainless Steel	JC8050 (JC7550)	90 - 110	0.10 - 0.20	ap	~3	~3.5	~3.5	~4	~4	~4	~4	~4
				ae	~20	~25	~32	~40	~55	~65	~80	~100
Martensitic Stainless Steel	JC8118	110 - 150	0.15 - 0.25	ap	~3	~3.5	~3.5	~4	~4	~4	~4	~4
				ae	~25	~32	~40	~50	~63	~80	~100	~125

Note

1. Please adjust cutting conditions according to machine rigidity or work rigidity.
2. In case of chatter occurring, recommended to reduce ap or rpm and keep feed per tooth.
3. ap should be reduced when using on low rigidity machine.
4. Use air blow.
5. When using for slot milling, apply 50% or less feed (Vf) from standard cutting condition.

Double sided insert with 6 cutting edge

SHOULDER SIX

Unique 3D insert

Due to arch-geometry on the peripheral cutting edge, cusp height can be smaller even in case of large ap.

Achieves low cutting force

Achieves high efficient & high precision machining for side walls.



Features

This tool can accommodate an array of applications such as face milling, slotting and plunging. The unique 3D design of the insert has 6 positive axial cutting edges which decreases tool pressure.

Double - sided insert with 6 cutting edge.

The robust insert is 7.5mm in thickness allowing for stable machining and longer tool life.



ISO	P					M					K				H		
	P01	P10	P20	P30	P40	M01	M10	M20	M30	M40	K01	K10	K20	K30	H01	H10	H20
Range	JC8118					JC8118					JC8118				JC8118		
	JC8050					JC8050											

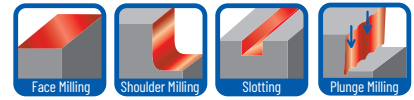

EXSIX
TYPE

Bore Type

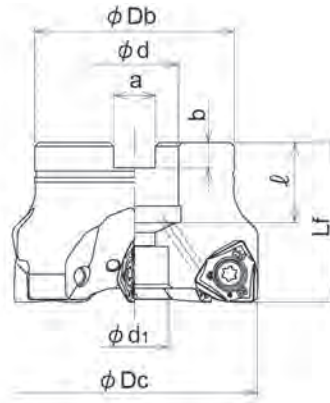

Fig.1
(Through coolant hole)

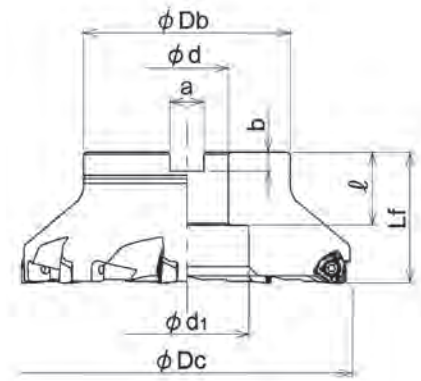

Fig.2
(No coolant hole)

Cat.No.	Stock	No. of inserts	Dimensions (mm)							Arbor set bolt	Weight (kg)	Inserts	Fig.	
			φDc	Lf	φDb	φd	φd1	a	b					ℓ
EXSIX-4050R-22	●	4	50	40	47	22	14	10.4	6.3	20	M10X1.5X25*	0.33	YCMU0907**ZER-PM	1
EXSIX-4052R-22	●		52								M10X1.5X25*	0.35		
EXSIX-5063R-22	●	5	63	50	17	10.4	6.3	20	20	M10	0.50			
EXSIX-5066R-22	●		66							M10	0.53			
EXSIX-6080R-27	●	6	80	50	56	27	20	12.4	7	22	M12X1.75X30*	0.93		
EXSIX-7100R-32	●	7	100		85	32	26	14.4	8	25	M16X2X30*	1.88		
EXSIX-8125R-40	●	8	125	63	100	40	32	16.4	9	32	M20X2.5X40*	3.62		
EXSIX-9160R-40	●	9	160				60				60	35		

Screw	Torque(N.m)	Wrench
CSW-513H	5.5	A-20

SHOULDER SIX

EXSIX Type

Insert

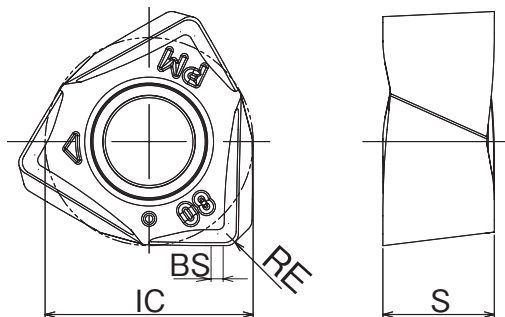

Cat.No.	Tolerance	PVD Coating		Dimensions (mm)			
		JC8050	JC8118	RE	BS	IC	S
YCMU090708ZER-PM	M	●	●	0.8	1.41	14	7.5
YCMU090716ZER-PM		●	●	1.6	0.62		

GRADE MARKING

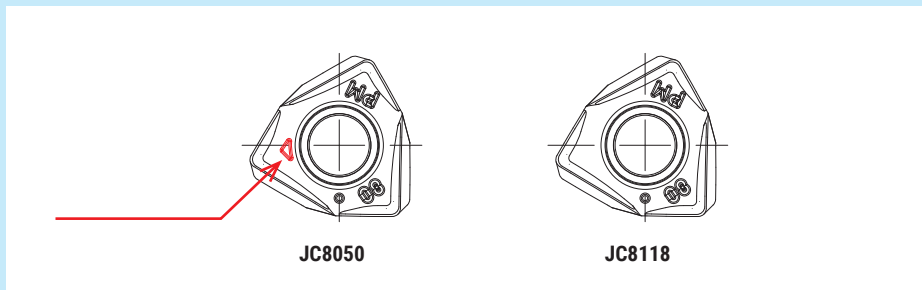

SHOULDER SIX

EXSIX Type

■ Recommended Cutting Conditions

Material	Grade	Shoulder Milling				Face Milling				Plunge Milling			
		Vc	fz	ap	ap x ae	Vc	fz	ap	ae	Vc	fz	ap	Pf
Carbon Steel below 250HB	JC8050	160	0.20	~9.0	~45	110	0.20	~4.0	~1.0Dc	180	0.25	~5	~0.5Dc
		- 200	- 0.35			- 150	- 0.30						
Cast Steel below 285HB	JC8050	140	0.20	~9.0	~45	110	0.20	~4.0	~1.0Dc	160	0.25	~5	~0.5Dc
		- 180	- 0.35			- 150	- 0.30						
Tool & Die Steel below 255HB	JC8050	160	0.20	~9.0	~45	110	0.15	~4.0	~1.0Dc	180	0.20	~5	~0.5Dc
		- 200	- 0.35			- 150	- 0.25						
Mold Steel 30-36HRC	JC8118	120	0.20	~9.0	~45	110	0.15	~4.0	~1.0Dc	130	0.20	~5	~0.5Dc
		- 150	- 0.35			- 130	- 0.25						
Mold Steel 38-43HRC	JC8118	90	0.15	~9.0	~30	90	0.10	~3.0	~1.0Dc	100	0.20	~5	~0.5Dc
		- 120	- 0.25			- 110	- 0.25						
Hardened Die Steel 42-52HRC	JC8118	80	0.10	~9.0	~25	70	0.10	~2.5	~0.8Dc	90	0.10	~5	~0.5Dc
		- 100	- 0.20			- 90	- 0.20						
Grey Cast Iron below 160-260HB	JC8118	210	0.20	~9.0	~45	130	0.20	~6.0	~1.0Dc	200	0.30	~5	~0.5Dc
		- 250	- 0.35			- 180	- 0.30						
Nodular Cast Iron below 170-300HB	JC8118	110	0.15	~9.0	~45	110	0.15	~4.0	~1.0Dc	130	0.20	~5	~0.5Dc
		- 150	- 0.30			- 130	- 0.25						
Austenitic Stainless Steel	JC8050	100	0.10	~9.0	~45	90	0.10	~4.0	~0.8Dc	110	0.15	~5	~0.5Dc
		- 120	- 0.20			- 110	- 0.20						
Martensitic Stainless Steel	JC8118	140	0.15	~9.0	~45	110	0.15	~4.0	~1.0Dc	160	0.20	~5	~0.5Dc
		- 180	- 0.30			- 150	- 0.25						

Note

1. Please adjust cutting conditions according to machine rigidity or work rigidity.
2. In case of chatter occurring, recommended to reduce ap or rpm and keep feed per tooth.
3. ap should be reduced when using on low rigidity machine.
4. Use air blow.
5. When using for slot milling, apply 50% or less feed (Vf) from standard cutting condition.
6. Ramping and helical interpolation are not recommended.

SIC-EVO

SSV Type

進化した。SIC-EVO



Capable of ramping & helical interpolation

Feature 1

Max. depth of cut (ap) = 15mm is possible.

Usable for a wide range of applications such as face milling, slotting, pocket milling & side milling.

Arc geometry on peripheral cutting edge

Cusp height can be smaller even in case of large ap. achieves high efficient & high precision machining for vertical walls.



High positive geometry with low cutting force

Feature 2

Available corner radius: R0.4, R0.8, R1.6, R2.0 & R3.0

■ Insert grades

ISO	P					M					K				H		
	P01	P10	P20	P30	P40	M01	M10	M20	M30	M40	K01	K10	K20	K30	H01	H10	H20
Range		JC8118						JC8118			JC8118				JC8118		
			JC8050					JC8050									

SSV
TYPE

Bore Type

Through
coolant
hole

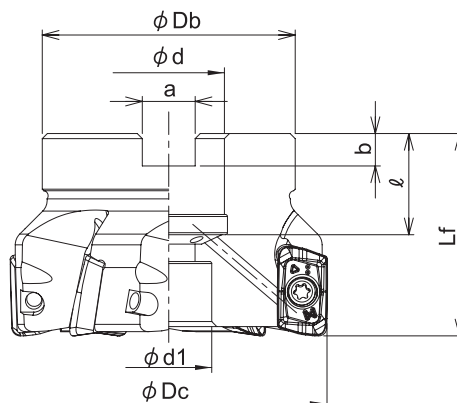

Cat.No.	Stock	No. of inserts	Dimensions (mm)								Arbor set bolt	Weight (kg)	Insert
			ϕD_c	Lf	ϕD_b	ϕd	ϕd_1	a	b	ℓ			
SSV-4040R-16	●	4	40	40	35	16	14	8.4	5.6	18	M8	0.20	ZOMT1605**ZER-PM ZOET1605**ZFR-NL
SSV-5050R-22	●	5	50		47	22	17	10.4	6.3	20	M10	0.33	
SSV-6063R-22	●	6	63		50	27	20	12.4	7	22	M10	0.52	
SSV-6063R-27	●			M12X1.75X30*	0.75								
SSV-7080R-27	●	7	80	50	60	27	20	12.4	7	22	M12X1.75X30	1.08	
SSV-8100R-32	●	8	100	85	32	26	14.4	8	25	M16X2X30*	1.95		
SSV-8125R-40	●		125	63	100	40	32	16.4	9	32	M20X2.5X40*	3.73	

Screw	Torque(N.m)	Wrench
DSW-4075H	3.6	A-15T

SIC-EVO

SSV Type

SSV
TYPE

Modular Type

Through
coolant
hole

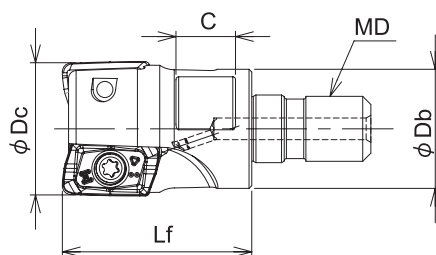
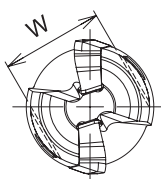

Cat.No.	Stock	No. of inserts	Dimensions (mm)						Insert
			ϕD_c	Lf	ϕD_b	MD	C	W	
SSV-2025-M12	●	2	25	35	22	M12	11	19	ZOMT1605**ZER-PM ZOET1605**ZFR-NL
SSV-2028-M12	○		28						
SSV-3030-M16	○	3	30	43	29	M16	12	22	
SSV-3032-M16	●		32						
SSV-3035-M16	●		35						
SSV-4040-M16	●	4	40						

Screw	Torque(N.m)	Wrench
DSW-4075H	3.6	A-15

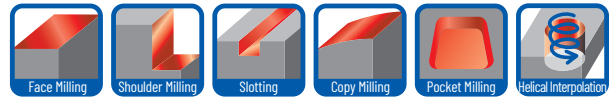

SSV
TYPE

Shank Type

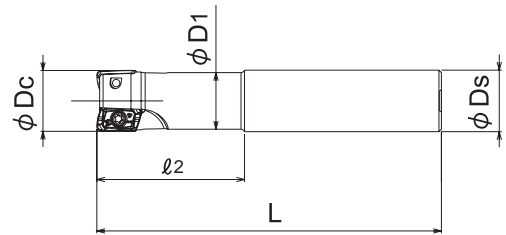

Cat.No.	Stock	No. of inserts	Dimensions (mm)					Insert
			φDc	ℓ2	L	φD1	φDs	
SSV-2025-60-S25+A	●	2	25	60	140	23	25	ZOMT1605**ZER-PM ZOET1605**ZFR-NL
SSV-2025-100-S25+A	●			100	180			
SSV-3032-70-S32+A	●	3	32	70	150	29	32	
SSV-3032-120-S32+A	●			120	200			
SSV-4040-50-S32+A	●	4	40	50	150	37	32	
SSV-4040-50L-S32+A	●				200			

Screw	Torque(N.m)	Wrench
DSW-4075H	3.6	A-15

SIC-EVO

SSV Type

Insert

For Steel



JC8050

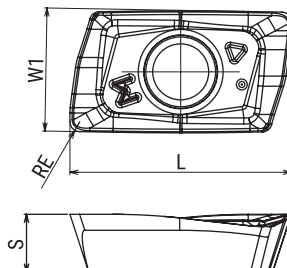

JC8118

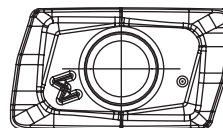

For Aluminum alloy

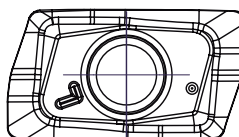

Cat.No.	Tolerance	PVD Coating		Uncoated	Dimensions (mm)			
		JC8050	JC8118	FC18	RE	L	W1	S
ZOMT160504ZER-PM	M	●	●		0.4	18	10	4.7
ZOMT160508ZER-PM		●	●		0.8			
ZOMT160516ZER-PM		●	●		1.6			
ZOMT160520ZER-PM		●	●		2			
ZOMT160530ZER-PM		●	●		3			
ZOET160504ZFR-NL	E			●	0.4			
ZOET160508ZFR-NL				●	0.8			

GRADE MARKINGS

JC8050

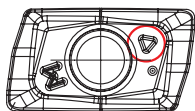

JC8118

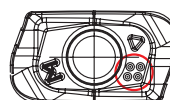
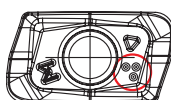
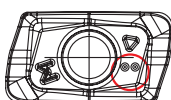
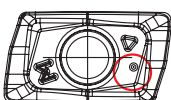
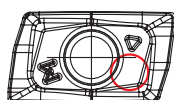
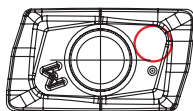

ZOMT160504ZER-PM

ZOMT160508ZER-PM

ZOMT160516ZER-PM

ZOMT160520ZER-PM

ZOMT160530ZER-PM

Recommended Data for Profile Milling

Ramping

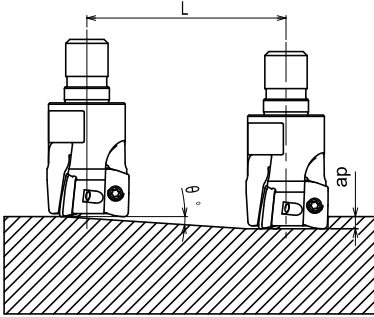

Helical interpolation

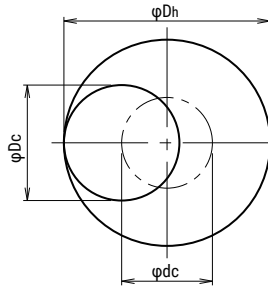
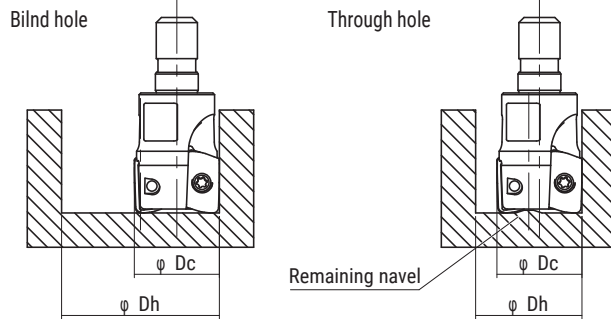

- In case of ramping and helical interpolation, apply 80% or less feed (Vf) from standard cutting condition table
- In case of drilling, apply 50% or less feed (Vf) from standard cutting condition table
- In case of helical interpolation, recommend wet cutting by coolant through the tool
- Long chips may come out in case of drilling, confirm safe operating conditions

- Calculation of tool pass dia.

$$\varphi_{Dc} = \varphi_{Dh} - \varphi_{Dc}$$

Tool pass dia. Bore dia. Tool Dia.

- Depth of cut per one circuit should not exceed max. depth of cut Ap
- Down cutting is recommended, tool pass rotation should be counterclockwise

ZOMT160504ZER-PM

Cat.No.	Tool dia. (mm)	Effective cutting dia. (mm)	Max. depth of cut : ap (mm)	Ramping		Helical interpolation			Max. drilling depth: Z
				Max. ramping angle θ	Max. depth of cut (ap) Total cutting length L(mm)	Through hole Min. Bore dia. (mm)	Blind hole Min. Bore dia. (mm)	Blind hole Max. Bore dia. (mm)	
SSV-2025-**	25	23.9	1.5	6.2	13.8	31	48	48.8	1.6
SSV-2028-M12	28	26.9	1.5	5.3	16.2	37	54	54.8	1.6
SSV-3030-**	30	28.9	1.5	4.8	17.9	41	58	58.8	1.6
SSV-3032-**	32	30.9	1.5	4.4	19.5	45	62	62.8	1.6
SSV-3035-M16	35	33.9	1.5	4.3	19.9	51	68	68.8	1.6
SSV-4040-**	40	38.9	1.5	3.6	23.8	61	78	78.8	1.6
SSV-5050R-**	50	48.9	1.5	2.4	35.8	81	98	98.8	1.4
SSV-6063R-**	63	61.9	1.5	1.7	50.5	107	124	124.8	1.4
SSV-7080R-**	80	78.9	1.5	1.2	71.6	141	158	158.8	1.4
SSV-8100R-**	100	98.9	1.5	0.9	95.5	181	198	198.8	1.4
SSV-8125R-**	125	123.9	1.5	0.65	132.2	231	248	248.8	1.4

ZOMT160508ZER-PM

Cat.No.	Tool dia. (mm)	Effective cutting dia. (mm)	Max. depth of cut : ap (mm)	Ramping		Helical interpolation			Max. drilling depth: Z
				Max. ramping angle θ	Max. depth of cut (ap) Total cutting length L(mm)	Through hole Min. Bore dia. (mm)	Blind hole Min. Bore dia. (mm)	Blind hole Max. Bore dia. (mm)	
SSV-2025-**	25	23.1	1.5	6.4	13.4	31	47.2	48	1.6
SSV-2028-M12	28	26.1	1.5	5.4	15.9	37	53.2	54	1.6
SSV-3030-**	30	28.1	1.5	4.8	17.9	41	57.2	58	1.6
SSV-3032-**	32	30.1	1.5	4.4	19.5	45	61.2	62	1.6
SSV-3035-M16	35	33.1	1.5	4.3	19.9	51	67.2	68	1.6
SSV-4040-**	40	38.1	1.5	3.6	23.8	61	77.2	78	1.6
SSV-5050R-**	50	48.1	1.5	2.4	35.8	81	97.2	98	1.4
SSV-6063R-**	63	61.1	1.5	1.7	50.5	107	123.2	124	1.4
SSV-7080R-**	80	78.1	1.5	1.2	71.6	141	157.2	158	1.4
SSV-8100R-**	100	98.1	1.5	0.9	95.5	181	197.2	198	1.4
SSV-8125R-**	125	123.1	1.5	0.65	132.2	231	247.2	248	1.4

ZOMT160516ZER-PM

Cat.No.	Tool dia. (mm)	Effective cutting dia. (mm)	Max.depth of cut: ap (mm)	Ramping		Helical interpolation			Max. drilling depth: Z
				Max. ramping angle θ	Max. depth of cut (ap) Total cutting length L(mm)	Through hole Min. Bore dia. (mm)	Blind hole Min. Bore dia. (mm)	Blind hole Max. Bore dia. (mm)	
SSV-2025-**	25	21.5	1.5	6.7	12.8	31	45.8	46.4	1.5
SSV-2028-M12	28	24.5	1.5	5.6	15.3	37	51.8	52.4	1.5
SSV-3030-**	30	26.5	1.5	5	17.1	41	55.8	56.4	1.5
SSV-3032-**	32	28.5	1.5	4.7	18.2	45	59.8	60.4	1.5
SSV-3035-M16	35	31.5	1.5	4.6	18.6	51	65.8	66.4	1.5
SSV-4040-**	40	36.5	1.5	3.8	22.6	61	75.8	76.4	1.5
SSV-5050R-**	50	46.5	1.5	2.5	34.4	81	95.8	96.4	1.4
SSV-6063R-**	63	59.5	1.5	1.8	47.7	107	121.8	122.4	1.4
SSV-7080R-**	80	76.5	1.5	1.2	71.6	141	155.8	156.4	1.4
SSV-8100R-**	100	96.5	1.5	0.9	95.5	181	195.8	196.4	1.4
SSV-8125R-**	125	121.5	1.5	0.65	132.2	231	245.8	246.4	1.4

ZOMT160520ZER-PM

Cat.No.	Tool dia. (mm)	Effective cutting dia. (mm)	Max.depth of cut: ap (mm)	Ramping		Helical interpolation			Max. drilling depth: Z
				Max. ramping angle θ	Max. depth of cut (ap) Total cutting length L(mm)	Through hole Min. Bore dia. (mm)	Blind hole Min. Bore dia. (mm)	Blind hole Max. Bore dia. (mm)	
SSV-2025-**	25	20.7	1.5	6.9	12.4	31	45	45.6	1.5
SSV-2028-M12	28	23.7	1.5	5.7	15.0	37	51	51.6	1.5
SSV-3030-**	30	25.7	1.5	5	17.1	41	55	55.6	1.5
SSV-3032-**	32	27.7	1.5	4.7	18.2	45	59	59.6	1.5
SSV-3035-M16	35	30.7	1.5	4.6	18.6	51	65	65.6	1.5
SSV-4040-**	40	35.7	1.5	3.8	22.6	61	75	75.6	1.5
SSV-5050R-**	50	45.7	1.5	2.5	34.4	81	95	95.6	1.4
SSV-6063R-**	63	58.7	1.5	1.8	47.7	107	121	121.6	1.4
SSV-7080R-**	80	75.7	1.5	1.2	71.6	141	155	155.6	1.4
SSV-8100R-**	100	95.7	1.5	0.9	95.5	181	195	195.6	1.4
SSV-8125R-**	125	120.7	1.5	0.65	132.2	231	245	245.6	1.4

ZOMT160530ZER-PM

Cat.No.	Tool dia. (mm)	Effective cutting dia. (mm)	Max.depth of cut: ap (mm)	Ramping		Helical interpolation			Max. drilling depth: Z
				Max. ramping angle θ	Max. depth of cut (ap) Total cutting length L(mm)	Through hole Min. Bore dia. (mm)	Blind hole Min. Bore dia. (mm)	Blind hole Max. Bore dia. (mm)	
SSV-2025-**	25	18.7	1.5	7.2	11.9	31	43	43.6	1.5
SSV-2028-M12	28	21.7	1.5	6	14.3	37	49	49.6	1.5
SSV-3030-**	30	23.7	1.5	5.3	16.2	41	53	53.6	1.5
SSV-3032-**	32	25.7	1.5	4.8	17.9	45	57	57.6	1.5
SSV-3035-M16	35	28.7	1.5	4.7	18.2	51	63	63.6	1.5
SSV-4040-**	40	33.7	1.5	3.9	22.0	61	73	73.6	1.5
SSV-5050R-**	50	43.7	1.5	2.5	34.4	81	93	93.6	1.4
SSV-6063R-**	63	56.7	1.5	1.8	47.7	107	119	119.6	1.4
SSV-7080R-**	80	73.7	1.5	1.3	66.1	141	153	153.6	1.4
SSV-8100R-**	100	93.7	1.5	0.95	90.5	181	193	193.6	1.4
SSV-8125R-**	125	118.7	1.5	0.65	132.2	231	243	243.6	1.4

Recommended Cutting Conditions - Shoulder Milling -

Material	Grade	Vc	fz		Tool dia. (mm)							
					25	32	40	50	63	80	100	125
Carbon Steel below 250HB	JC8050	160 - 200	0.20 - 0.35	ap	~10.0	~12.0	~15.0	~15.0	~15.0	~15.0	~15.0	~15.0
				ap x ae	~15	~24	~30	~40	~45	~45	~45	~45
Cast Steel below 285HB	JC8050	140 - 180	0.20 - 0.30	ap	~10.0	~12.0	~15.0	~15.0	~15.0	~15.0	~15.0	~15.0
				ap x ae	~15	~24	~30	~40	~45	~45	~45	~45
Tool & Die Steel below 255HB	JC8050	160 - 200	0.20 - 0.35	ap	~10.0	~12.0	~15.0	~15.0	~15.0	~15.0	~15.0	~15.0
				ap x ae	~15	~24	~30	~40	~45	~45	~45	~45
Mold Steel 30-36HRC	JC8118	120 - 150	0.20 - 0.35	ap	~10.0	~12.0	~15.0	~15.0	~15.0	~15.0	~15.0	~15.0
				ap x ae	~15	~24	~30	~40	~45	~45	~45	~45
Mold Steel 38-43HRC	JC8118	90 - 120	0.15 - 0.25	ap	~10.0	~12.0	~15.0	~15.0	~15.0	~15.0	~15.0	~15.0
				ap x ae	~12	~18	~20	~30	~30	~45	~45	~45
Hardened Die Steel 42-52HRC	JC8118	80 - 100	0.10 - 0.20	ap	~10.0	~12.0	~12.0	~15.0	~15.0	~15.0	~15.0	~15.0
				ap x ae	~8	~12	~12	~18	~25	~45	~45	~45
Grey Cast Iron below 160-260HB	JC8118	210 - 250	0.20 - 0.35	ap	~10.0	~12.0	~15.0	~15.0	~15.0	~15.0	~15.0	~15.0
				ap x ae	~15	~24	~30	~40	~45	~45	~45	~45
Nodular Cast Iron below 170-300HB	JC8118	110 - 150	0.15 - 0.30	ap	~10.0	~12.0	~15.0	~15.0	~15.0	~15.0	~15.0	~15.0
				ap x ae	~15	~24	~30	~40	~45	~45	~45	~45
Austenitic Stainless Steel	JC8050	100 - 120	0.10 - 0.20	ap	~10.0	~12.0	~15.0	~15.0	~15.0	~15.0	~15.0	~15.0
				ap x ae	~15	~24	~30	~40	~45	~45	~45	~45
Martensitic Stainless Steel	JC8118	140 - 180	0.15 - 0.30	ap	~10.0	~12.0	~15.0	~15.0	~15.0	~15.0	~15.0	~15.0
				ap x ae	~15	~24	~30	~40	~45	~45	~45	~45
Aluminium	FC18	700 - 900	0.07 - 0.20	ap	~15.0	~15.0	~15.0	~15.0	~15.0	~15.0	~15.0	~15.0
				ap x ae	~75	~75	~75	~75	~75	~75	~75	~75

Note

1. Please adjust cutting conditions according to machine rigidity or work rigidity.
2. In case of chatter occurring, recommended to reduce ap or rpm and keep feed per tooth.
3. ap should be reduced when using on low rigidity machine.
4. Use airblow. (For Aluminium machining Wet cutting is recommended.)

Recommended Cutting Conditions - Face Milling -

Material	Grade	Vc	fz		Tool dia. (mm)							
					25	32	40	50	63	80	100	125
Carbon Steel below 250HB	JC8050	110 - 150	0.20 - 0.35	ap	~3.0	~3.5	~3.5	~4.0	~4.0	~4.0	~4.0	~4.0
				ae	~25	~32	~40	~50	~63	~80	~100	~125
Cast Steel below 285HB	JC8050	110 - 150	0.20 - 0.35	ap	~3.0	~3.5	~3.5	~4.0	~4.0	~4.0	~4.0	~4.0
				ae	~25	~32	~40	~50	~63	~80	~100	~125
Tool & Die Steel below 255HB	JC8050	110 - 150	0.15 - 0.30	ap	~3.0	~3.5	~3.5	~4.0	~4.0	~4.0	~4.0	~4.0
				ae	~25	~32	~40	~50	~63	~80	~100	~125
Mold Steel 30-36HRC	JC8118	110 - 130	0.15 - 0.30	ap	~3.0	~3.5	~3.5	~4.0	~4.0	~4.0	~4.0	~4.0
				ae	~25	~32	~40	~50	~63	~80	~100	~125
Mold Steel 38-43HRC	JC8118	90 - 110	0.15 - 0.25	ap	~2.0	~2.5	~2.5	~3.0	~3.0	~3.0	~3.0	~3.0
				ae	~25	~32	~40	~50	~63	~80	~100	~125
Hardened Die Steel 42-52HRC	JC8118	70 - 90	0.10 - 0.20	ap	~1.5	~2.0	~2.0	~2.5	~2.5	~2.5	~2.5	~2.5
				ae	~20	~26	~32	~40	~55	~65	~80	~100
Grey Cast Iron below 160-260HB	JC8118	130 - 200	0.20 - 0.35	ap	~5.0	~5.5	~5.5	~6.0	~6.0	~6.0	~6.0	~6.0
				ae	~25	~32	~40	~50	~63	~80	~100	~125
Nodular Cast Iron below 170-300HB	JC8118	110 - 130	0.15 - 0.30	ap	~3.0	~3.5	~3.5	~4.0	~4.0	~4.0	~4.0	~4.0
				ae	~25	~32	~40	~50	~63	~80	~100	~125
Austenitic Stainless Steel	JC8050	90 - 110	0.10 - 0.20	ap	~3.0	~3.5	~3.5	~4.0	~4.0	~4.0	~4.0	~4.0
				ae	~20	~26	~32	~40	~55	~65	~80	~100
Martensitic Stainless Steel	JC8118	110 - 150	0.15 - 0.30	ap	~3.0	~3.5	~3.5	~4.0	~4.0	~4.0	~4.0	~4.0
				ae	~25	~32	~40	~50	~63	~80	~100	~125
Aluminium	FC18	700 - 900	0.07 - 0.20	ap	~7.0	~7.0	~7.0	~7.0	~7.0	~7.0	~7.0	~7.0
				ae	~18	~22	~28	~35	~44	~56	~70	~87

Note

1. Please adjust cutting conditions according to machine rigidity or work rigidity.
2. In case of chatter occurring, recommended to reduce ap or rpm and keep feed per tooth.
3. ap should be reduced when using on low rigidity machine.
4. Use airflow. (For Aluminium machining Wet cutting is recommended.)

MIRROR BALL

BNM Type

BNM
TYPE

Shank Type

High Precision Indexable Ball Nose End Mill

- Insert radius from accuracy is **below ± 0.010 mm** when fixed to the holder.
(accuracy **below ± 0.006 mm** in insert alone).

Cat.No.	Stock	Dimensions (mm)									Parts		Inserts	Fig.	
		φD_c	R	r_1	r_2	L	φD_1	θ	θ_k	φD_s	Screws	Wrench			
BNMS-060017S-S06C	●	6	3	—	17	60	5.5	—	—	6	FSW-2005H	A-06	BNM-060	1	
BNMS-060030T-S10C	●			15	30	80		6°	4°14'	10				2	
BNMM-060035S-S06C	●			—	35	92		—	—	6				—	
BNML-060017S-S06C	●			17	120										
BNMS-080025S-S08C	●	8	4	—	25	90	7.5	—	—	8	FSW-2506H	A-07	BNM-080 RNM-080	1	
BNMM-080035S-S08C	●			35	92	—		—	8	—					
BNML-080075S-S08C	●			75	140	—		—	8	—					
BNML-080095S-S08C	●			95	160	—		—	8	—					
BNML-080075T-S12C	●			20	75	132		2°	1°37'	12				2	
BNMS-100030S-S10C	●	10	5	—	30	100	9.5	—	—	10	FSW-3007H	A-08	BNM-100 RNM-100	1	
BNMM-100043S-S10C	●			43	100	—		—	10	—					
BNML-100075S-S10C	●			75	140	—		—	10	—					
BNML-100080S-S10C	●			80	220	—		—	10	—					
BNML-100095S-S10C	●			95	160	—		—	10	—					
BNML-100140S-S10C	●			140	220	—		—	10	—					
BNML-100075T-S12C	●	32.1	75	132	1°30'	0°49'	12	2							
BNMS-120028S-S12C	●	12	6	—	28	84	11.5	—	—	12	FSW-3509H	A-10	BNM-120 RNM-120	1	
BNMM-120053S-S12C	●			53	110	—		—	12	—					
BNML-120095S-S12C	●			95	160	—		—	12	—					
BNML-120100S-S12C	●			100	220	—		—	12	—					
BNML-120085T-S16C	●			33.8	85	145		2°	1°27'	16				2	
BNML-120130S-S12C	●			—	130	200		—	—	12				—	
BNML-120150S-S12C	●	—	150	220	—	—	12	1							
BNMS-160033S-S16C	●	16	8	—	33	93	15	—	—	16	FSW-4013H	A-15	BNM-160 RNM-160	1	
BNMM-160063T-S20C	●			37.5	63	123		4°	2°5'	20					2
BNML-160070S-S16C	●			—	70	140		—	—	16					—
BNML-160090S-S16C	●			—	90	160		—	—	16				—	
BNML-160100S-S16C	●			—	100	220		—	—	16				—	
BNML-160100T-S20C	●			44.5	100	166		2°	1°15'	20				2	
BNML-160110S-S16C	●			—	110	180		—	—	16				—	
BNML-160150S-S16C	●			—	150	220		—	—	16				—	
BNMS-200039S-S20C	●	20	10	—	39	105	19	—	—	20	FSW-5016H	A-20W	BNM-200 RNM-200	1	
BNMM-200075S-S20C	●			75	141	—		—	20	—					

MIRROR BALL

BNM Type

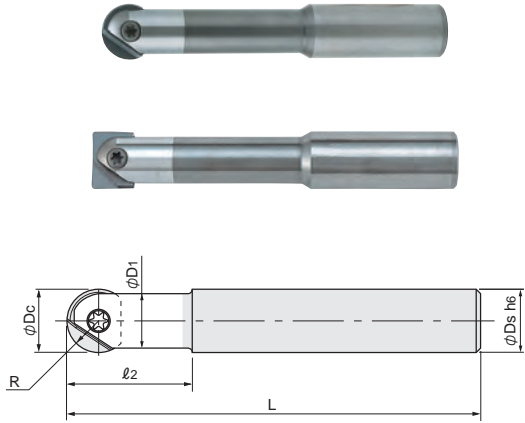

Fig 1

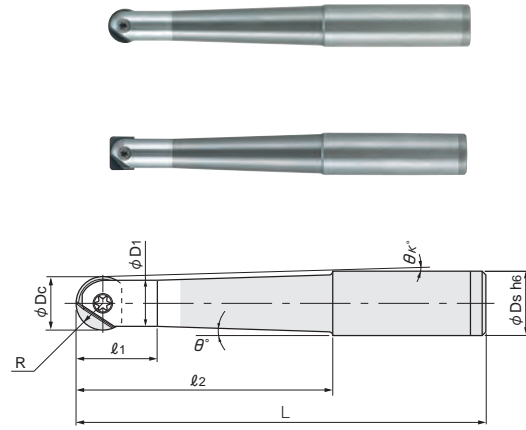

Fig 2

Cat.No.	Stock	Dimensions (mm)									Parts		Inserts	Fig.
		φDc	R	l1	l2	L	φD1	θ	θk	φDs	Screws	Wrench		
BNML-200100S-S20C	●	20	10	64.3	100	220	19	2°	1°22'	20	FSW-5016H	A-20W	BNM-200 RNM-200	1
BNML-200105S-S20C	●				105	180								
BNML-200115T-S25C	●				115	191								
BNML-200125S-S20C	●				125	200								
BNML-200170S-S20C	●				170	250								
BNML-200220S-S20C	●				220	300								
BNMM-250090S-S25C	●	25	12.5	90	166	24	-	-	25	FSW-6020	A-30	BNM-250 RNM-250	1	
BNML-250100S-S25C	●				100									220
BNML-250140S-S25C	●				140									250
BNML-250170S-S25C	●				170									250
BNMM-300120S-S32C	●	30	15	120	200	29	-	-	32	FSW-8025S	A-30	BNM-300/320 RNM-300	1	
BNML-300100S-S32C	●				100									220
BNML-300140S-S32C	●				140									250
BNML-300170S-S32C	●				170									250
BNML-300220S-S32C	●				220									300

Screw	Torque(N.m)
FSW-2005H	0.5
FSW-2506H	0.9
FSW-3007H	1.2
FSW-3509H	2.0
FSW-4013H	3.0
FSW-5016H	4.0
FSW-6020	6.0
FSW-8025S	6.0

MIRROR BALL

BNM Type

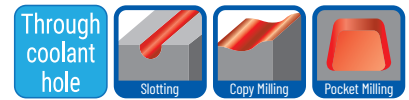

MBX TYPE

Modular Type

- Insert radius from accuracy is **below ±0.010 mm** when fixed to the holder (accuracy **below ±0.006 mm** in insert alone).
- O.D. runout is below 0.015 mm when fixed to MSN carbide shank holder.

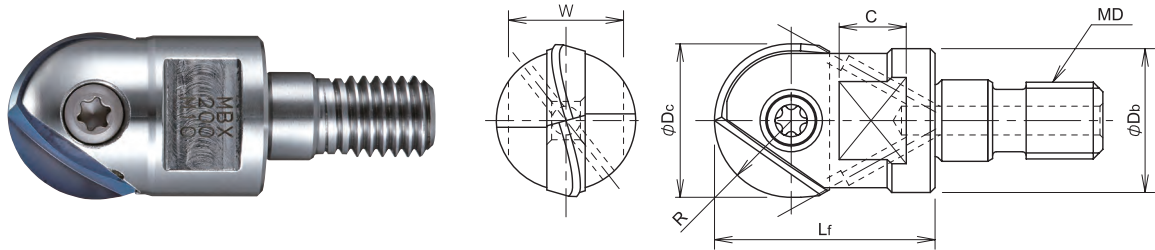

Cat.No.	Stock	Dimensions (mm)							Parts		Inserts
		φDc	R	Lf	φDb	MD	C	W	Screws	Wrench	
MBX-100-M6	●	10	5	18	9.7	M6	6.5	8	FSW-3007H	A-08	BNM-100
MBX-120-M6	●	12	6	20	11.5	M6			FSW-3509H	A-10	BNM-120
MBX-160-M8	●	16	8	23	15	M8	8	12	FSW-4013H	A-15	BNM-160
MBX-200-M10	●	20	10	30	19	M10			14	FSW-5016H	A-20W
MBX-250-M12	●	25	12.5	35	24	M12	10	17	FSW-6020	A-30	BNM-250
MBX-300-M16	●	30	15	43	29	M16	12.5	22	FSW-8025S	A-30	BNM-300/320

Screw	Torque(N.m)
FSW-3007H	1.2
FSW-3509H	2.0
FSW-4013H	3.0
FSW-5016H	4.0
FSW-6020	6.0
FSW-8025S	6.0

■ **Spanner**

	Cat.No.	MD	Torque	width across flat	Thickness	Length
	DS-08	M6	8.0 N.m	8	4	85
	DS-12	M8	16 N.m	12	4	93

Radius accuracy
± 0.006 mm

BNM
TYPE

Neutral style geometry
strictly for finishing applications

● **DH111, JC10000, KT9**

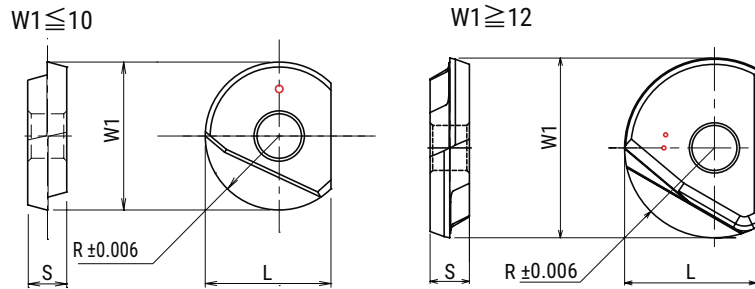
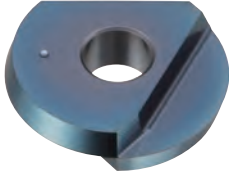

● **CBN**

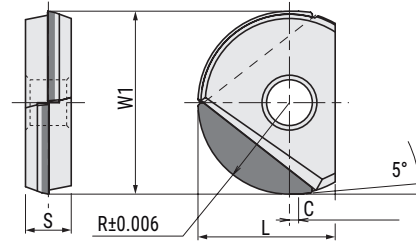
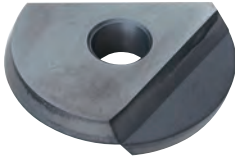

Cat.No.	PVD Coating		CBN		Diamond Coating		Uncoated		Dimensions(mm)				
	DH111	JBN245	JC10000	KT9	R	W1	L	C	S				
BNM-060	●		○	●	3	6	5	-	2				
BNM-080	●		○	●	4	8	7	-	2.4				
BNM-100	●		○	●	5	10	8.5	-	2.6				
BNM-120	●		○	●	6	12	10	-	3				
BNM-160	●	○	○	●	8	16	12	0.8	4				
BNM-200	●	○	○	●	10	20	15	1	5				
BNM-250	●	○		○	12.5	25	18.5	1	6				
BNM-300	○	○		○	15	30	22.5	1	7				
BNM-320	●			○	16	32	23.5	-	7				

MIRROR BALL **BNM Type**

Radius accuracy ± 0.006 mm

BNM-SS
TYPE

Sharp Helical geometry

good for finishing and semi finishing general steel , mold steel & stainless steel

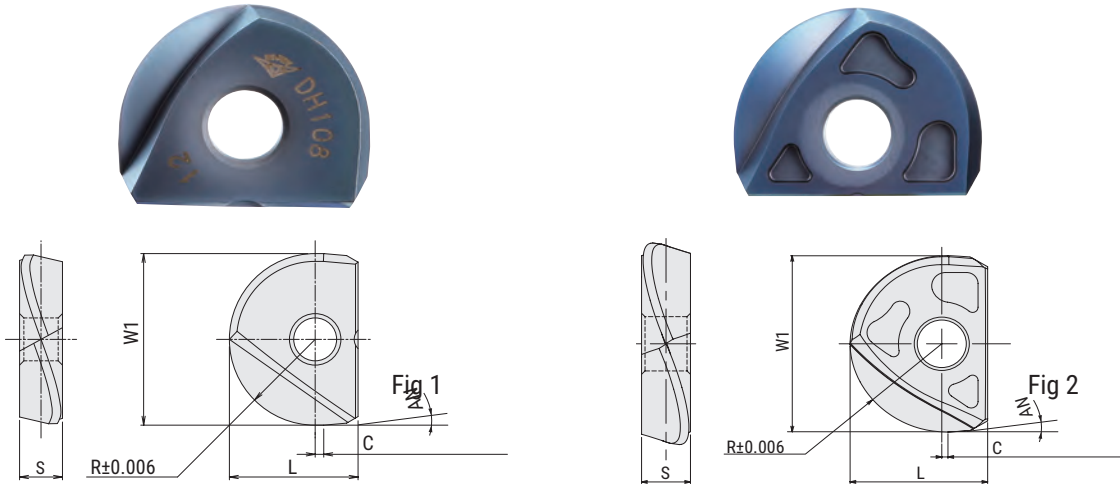

Cat.No.	PVD Coating		Dimensions(mm)						Fig.
	DH108	DS108	R	L	W1	S	C	AN	
BNM-060-SS	●	●	3	5	6	2	—	10°	1
BNM-080-SS	●	●	4	7	8	2.4	0.5	5°	
BNM-100-SS	●	●	5	8.5	10	2.6	1		
BNM-120-SS	●	●	6	10	12	3			
BNM-160-SS	●	●	8	12	16	4			
BNM-200-SS	●	●	10	15	20	5			
BNM-250-SS	●	●	12.5	18.5	25	6		7	2
BNM-300-SS	○	○	15	22.5	30				
BNM-320-SS	●	●	16	23.5	32				

Radius accuracy ± 0.006 mm

BNM-S
TYPE

Sharp Helical geometry

good for semi-finishing & finishing non-ferrous metals such as aluminium, copper

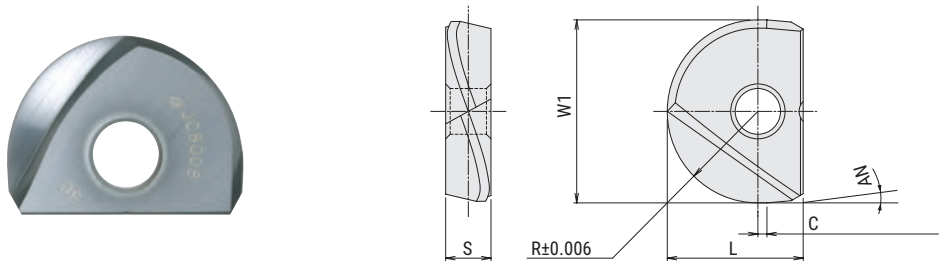

Cat.No.	Uncoated	DLC Coating	Dimensions (mm)					
	FZ05	JC20003	R	L	W1	S	C	AN
BNM-060-S	●	○	3	5	6	2	—	10°
BNM-080-S	●	○	4	7	8	2.4	0.5	5°
BNM-100-S	●	○	5	8.5	10	2.6	1	
BNM-120-S	●	○	6	10	12	3		
BNM-160-S	●	○	8	12	16	4		
BNM-200-S	●	○	10	15	20	5		
BNM-250-S	○	○	12.5	18.5	25	6		7
BNM-300-S	○	○	15	22.5	30	7		

MIRROR BALL

BNM Type

BNM-TG
TYPE

Helical geometry

good for finishing hard material/weld up to 60 HRC

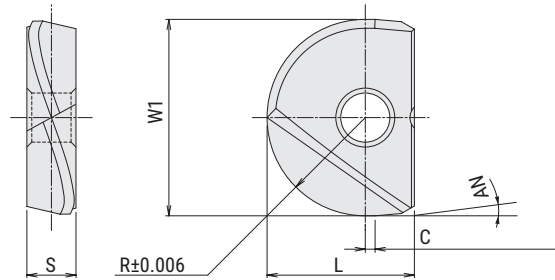
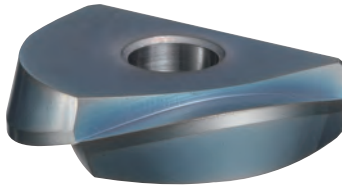
Radius accuracy
 ± 0.006 mm

Cat.No.	PVD Coating	Dimensions(mm)					
	DH102	R	L	W1	S	C	AN
BNM-060-TG	●	3	5	6	2	—	10°
BNM-080-TG	●	4	7	8	2.4	0.5	5°
BNM-100-TG	●	5	8.5	10	2.6	1	
BNM-120-TG	●	6	10	12	3	1.5	
BNM-160-TG	●	8	12	16	4		
BNM-200-TG	●	10	15	20	5	2	
BNM-250-TG	●	12.5	18.5	25	6		
BNM-300-TG	○	15	22.5	30	7		
BNM-320-TG	●	16	32	32			

MIRROR BALL

BNM Type

Radius accuracy
 ± 0.006 mmBNM-TS
TYPE

High Helix geometry

good for semi-finishing & finishing hard materials up to 60HRC

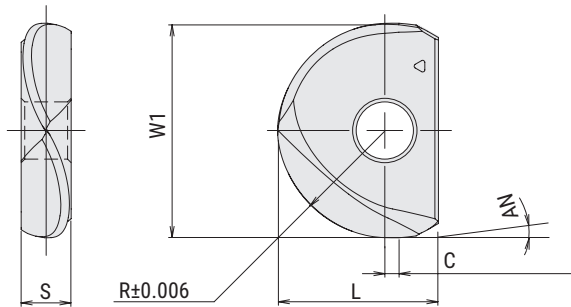
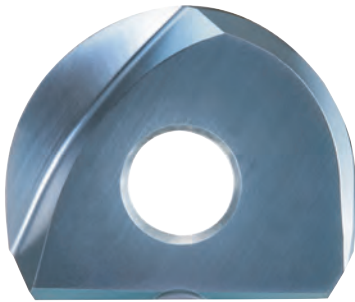

Cat.No.	PVD Coating	Dimensions(mm)					
	DH102	R	W1	L	S	C	AN
BNM-060-TS	●	3	6	5	2	—	10°
BNM-080-TS	●	4	8	7	2.4	0.5	5°
BNM-100-TS	●	5	10	8.5	2.6	1	
BNM-120-TS	●	6	12	10	3	1.5	
BNM-160-TS	●	8	16	12	4		
BNM-200-TS	●	10	20	15	5	2	
BNM-250-TS	●	12.5	25	18.5	6		
BNM-300-TS	○	15	30	22.5	7		
BNM-320-TS	●	16	32	23.5			

MIRROR BALL

BNM Type

■ Controlled Torque Wrenches (with replaceable blade)

Wrenches are pre-set to protect screws and bodies against damage during both the tightening and loosening process



● Controlled Torque Wrenches (with replaceable blade)

Cat. No.	Torque #	Screw torque	Replacement blade	Applicable inserts
TQC-06	T6	0.5Nm	B-06	BNM○-06... RNM○-06...
TQC-07	T7	0.9Nm	B-07	BNM○-08... RNM○-08...
TQC-08	T8	1.2Nm	B-08	BNM○-10... RNM○-10...
TQC-10	T10	2.0Nm	B-10	BNM○-12... RNM○-12...

● Replacement blade

Cat. No.	Torque #	Applicable wrench
B-06	T6	TQC-06
B-07	T7	TQC-07
B-08	T8	TQC-08
B-10	T10	TQC-10

★ Insert mounting information

1. Make sure the insert seat on body is carefully cleaned.
2. Make sure insert itself is clean, especially hole and face location.
3. Change insert screw when threads start to wear.
(approximately every 10-15 inserts)
4. Do not over tighten screw, see table for torque specifications.

tool dia.(mm)	Tecomended torque
φDc	N·m
6	0.5
8	0.9
10	1.2
12	2.0
16	3.0
20	4.0
25	5.0
30	6.0
32	6.0

MIRROR BALL

BNM Type

■ Grade Selection Guide

Material	BNM				BNM-S		BNM-SS		BNM-TG	BNM-TS
	DH111	JC10000	KT9	JBN245	FZ05	JC20003	DH108	DS108	DH102	DH102
Carbon steel below 250HB	◎☆						◎			
Cast steel below 285HB	◎☆						◎			
Tool & Die steel below 255HB	◎☆						◎			
Mold steel 30 - 36HRC	○						◎			
Mold steel 38 - 43HRC	○						◎			
Hardened die steel 42 - 52HRC	○						◎		○	○
Hardened die steel 55 - 62HRC							○		◎	◎
HSS 63 - 70HRC									◎	◎
Grey cast iron 160 - 260HB	○			★			○		◎	◎
Nodular cast iron 170 - 300HB	○			★			○		◎	◎
Austenitic stainless steel (304,316,317) 17Cr	◎☆						◎			
Ferritic & martensitic stainless steel (403,420J2,430) 13Cr	◎☆						◎			
Aluminium alloy (A5052)			◎		◎	◎				
Aluminium alloy (A7075)			◎		◎	◎				
Aluminium alloy Si below 13%			◎		◎	◎				
Copper alloy (C1100)			◎		◎	◎				
Graphite		○				◎				
Titanium alloy (Ti-6Al-4V) 35 - 43HRC	◎☆						◎	◎		
Heat resistant alloy (INCO718) 35 - 43HRC	◎☆						◎			

◎ : First choice ○ : Second choice ☆ : Wet cutting ★ : High speed machining

Recommended Cutting Conditions

Material	Cat.No	Grade		Tool dia.(mm)									
				6	8	10	12	16	20	25	30	32	
Carbon steel below 250HB	BNM BNM-SS	DH111 DH108	$n(\text{min}^{-1})$	18,570	13,930	12,730	10,610	8,950	7,160	6,370	5,310	4,970	
			Vf(mm/min)	5,570	4,180	5,090	4,240	5,370	5,010	4,460	3,720	3,480	
			$\Delta p(\text{mm})$	0.1	0.1	0.15	0.15	0.15	0.15	0.15	0.15	0.15	0.15
			$\Delta e(\text{mm})$	0.1	0.15	0.2	0.2	0.25	0.3	0.4	0.5	0.5	
Cast steel below 285HB	BNM BNM-SS	DH111 DH108	$n(\text{min}^{-1})$	18,570	13,930	12,730	10,610	8,950	7,160	6,370	5,310	4,970	
			Vf(mm/min)	5,570	4,180	5,090	4,240	5,370	5,010	4,460	3,720	3,480	
			$\Delta p(\text{mm})$	0.1	0.1	0.15	0.15	0.15	0.15	0.15	0.15	0.15	0.15
			$\Delta e(\text{mm})$	0.1	0.15	0.2	0.2	0.25	0.3	0.4	0.5	0.5	
Tool & Die steel below 255HB	BNM BNM-SS	DH111 DH108	$n(\text{min}^{-1})$	18,570	13,930	12,730	10,610	8,950	7,160	6,370	5,310	4,970	
			Vf(mm/min)	5,570	4,180	5,090	4,240	5,370	5,010	4,460	3,720	3,480	
			$\Delta p(\text{mm})$	0.1	0.1	0.15	0.15	0.15	0.15	0.15	0.15	0.15	0.15
			$\Delta e(\text{mm})$	0.1	0.15	0.2	0.2	0.25	0.3	0.4	0.5	0.5	
Mold steel 30 - 36HRC	BNM BNM-SS	DH111 DH108	$n(\text{min}^{-1})$	18,570	13,930	12,730	10,610	8,950	7,160	6,370	5,310	4,970	
			Vf(mm/min)	5,570	4,180	5,090	4,240	5,370	5,010	4,460	3,720	3,480	
			$\Delta p(\text{mm})$	0.05	0.05	0.1	0.1	0.1	0.1	0.1	0.1	0.1	0.1
			$\Delta e(\text{mm})$	0.1	0.15	0.2	0.2	0.25	0.3	0.4	0.5	0.5	
Mold steel 38 - 43HRC	BNM BNM-SS	DH111 DH108	$n(\text{min}^{-1})$	15,920	11,940	11,140	9,280	7,960	6,370	5,730	4,770	4,480	
			Vf(mm/min)	3,180	2,390	3,340	2,780	3,980	3,820	3,440	2,860	2,690	
			$\Delta p(\text{mm})$	0.05	0.05	0.1	0.1	0.1	0.1	0.1	0.1	0.1	
			$\Delta e(\text{mm})$	0.1	0.15	0.2	0.2	0.25	0.3	0.4	0.5	0.5	
Hardened die steel 42 - 52HRC	BNM BNM-SS	DH111 DH108	$n(\text{min}^{-1})$	13,260	9,950	9,550	7,960	6,960	5,570	5,090	4,240	3,980	
			Vf(mm/min)	2,650	1,990	2,870	2,390	3,480	3,340	3,050	2,540	2,390	
			$\Delta p(\text{mm})$	0.05	0.05	0.1	0.1	0.1	0.1	0.1	0.1	0.1	
			$\Delta e(\text{mm})$	0.1	0.15	0.2	0.2	0.25	0.3	0.4	0.5	0.5	
Hardened die steel 55 - 62HRC	BNM-TG BNM-TS	DH102	$n(\text{min}^{-1})$	10,610	7,960	7,960	6,630	5,970	4,770	4,460	3,710	3,480	
			Vf(mm/min)	2,120	1,590	2,390	1,990	2,990	2,860	2,680	2,230	2,090	
			$\Delta p(\text{mm})$	0.05	0.05	0.1	0.1	0.1	0.1	0.1	0.1	0.1	
			$\Delta e(\text{mm})$	0.1	0.15	0.15	0.2	0.25	0.3	0.4	0.5	0.5	
HSS 63 - 70HRC	BNM-TG BNM-TS	DH102	$n(\text{min}^{-1})$	7,960	5,970	6,370	5,310	4,970	3,980	3,820	3,180	2,980	
			Vf(mm/min)	1,590	1,190	1,270	1,060	1,490	1,190	1,530	1,270	1,190	
			$\Delta p(\text{mm})$	0.05	0.05	0.05	0.05	0.05	0.05	0.05	0.05	0.05	
			$\Delta e(\text{mm})$	0.05	0.1	0.1	0.1	0.1	0.15	0.2	0.3	0.3	
Grey & Nodular cast iron below 300 HB	BNM BNM-TG BNM-TS	DH111 DH102	$n(\text{min}^{-1})$	18,570	13,930	12,730	10,610	8,950	7,160	6,370	5,310	4,970	
			Vf(mm/min)	7,430	5,570	6,370	5,310	6,270	5,730	5,100	4,250	3,980	
			$\Delta p(\text{mm})$	0.1	0.1	0.15	0.15	0.15	0.15	0.15	0.15	0.15	
			$\Delta e(\text{mm})$	0.1	0.15	0.2	0.2	0.25	0.3	0.4	0.5	0.5	
Stainless steel	BNM BNM-SS	DH111 DH108	$n(\text{min}^{-1})$	18,570	13,930	12,730	10,610	8,950	7,160	6,370	5,310	4,970	
			Vf(mm/min)	5,570	4,180	5,090	4,240	5,370	5,010	4,460	3,720	3,480	
			$\Delta p(\text{mm})$	0.1	0.1	0.15	0.15	0.15	0.15	0.15	0.15	0.15	
			$\Delta e(\text{mm})$	0.1	0.15	0.2	0.2	0.25	0.3	0.4	0.5	0.5	
Aluminium	BNM BNM-S	KT9 FZ05 JC20003	$n(\text{min}^{-1})$	23,870	17,900	15,920	13,260	10,940	8,750	7,640	6,370	5,970	
			Vf(mm/min)	9,550	7,160	7,960	6,630	7,660	7,000	6,110	5,100	4,780	
			$\Delta p(\text{mm})$	0.2	0.2	0.25	0.25	0.25	0.25	0.25	0.25	0.25	
			$\Delta e(\text{mm})$	0.1	0.15	0.2	0.2	0.25	0.3	0.4	0.5	0.5	
Copper alloy	BNM BNM-S	KT9 FZ05 JC20003	$n(\text{min}^{-1})$	23,870	17,900	15,920	13,260	10,940	8,750	7,640	6,370	5,970	
			Vf(mm/min)	9,550	7,160	7,960	6,630	7,660	7,000	6,110	5,100	4,780	
			$\Delta p(\text{mm})$	0.15	0.15	0.2	0.2	0.2	0.2	0.2	0.2	0.2	
			$\Delta e(\text{mm})$	0.1	0.15	0.2	0.2	0.25	0.3	0.4	0.5	0.5	
Graphite	BNM BNM-S	JC10000 JC20003	$n(\text{min}^{-1})$	23,870	17,900	15,920	13,260	10,940	8,750	7,640	6,370	5,970	
			Vf(mm/min)	9,550	7,160	7,960	6,630	7,660	7,000	6,110	5,100	4,780	
			$\Delta p(\text{mm})$	0.15	0.15	0.2	0.2	0.2	0.2	0.2	0.2	0.2	
			$\Delta e(\text{mm})$	0.1	0.15	0.2	0.2	0.25	0.3	0.4	0.5	0.5	
Titanium alloy (Ti-6Al-4V)	BNM BNM-SS	DH111 DS108	$n(\text{min}^{-1})$	10,610	7,960	9,550	7,960	5,970	4,770	4,460	3,710	3,480	
			Vf(mm/min)	3,180	2,390	3,820	3,180	2,990	2,860	2,680	2,230	2,090	
			$\Delta p(\text{mm})$	0.05	0.05	0.1	0.1	0.1	0.1	0.1	0.1	0.1	
			$\Delta e(\text{mm})$	0.1	0.15	0.15	0.2	0.25	0.3	0.4	0.5	0.5	
Heat resistant alloy (INC0718)	BNM BNM-SS	DH111 DS108	$n(\text{min}^{-1})$	7,960	5,970	6,370	5,310	4,970	3,980	3,820	3,180	2,980	
			Vf(mm/min)	1,590	1,190	1,910	1,590	1,990	1,590	1,530	1,270	1,190	
			$\Delta p(\text{mm})$	0.05	0.05	0.1	0.1	0.1	0.1	0.1	0.1	0.1	
			$\Delta e(\text{mm})$	0.1	0.1	0.1	0.1	0.1	0.15	0.2	0.3	0.3	

Note 1. Please adjust cutting conditions according to machine rigidity or work rigidity.

2. These cutting conditions represent stable machining at length 3 x Dc.

Please adjust cutting conditions according to overhang length.

3. In case of chatter occurring, recommended to reduce ap or feed.

4. Use air blow.

Overhang length ℓ/Dc	n (min ⁻¹)	Vf (mm/min)
~3Dc	100%	100%
3Dc~5Dc	70%	70%
5Dc~10Dc	50%	50%

MIRROR BALL

BNM Type

■ Recommended Cutting Conditions

Material	Cat.No	Grade		Tool dia.(mm)			
				16	20	25	30
Grey cast iron 160- 260 HB	BNM	JBN245	$n(\text{min}^{-1})$	23,870	19,100	15,280	12,730
			$V_f(\text{mm}/\text{min})$	11,940	11,460	9,170	8,910
			$a_p(\text{mm})$	0.05	0.05	0.05	0.05
			$a_e(\text{mm})$	0.25	0.3	0.4	0.5
Nodular cast iron 170- 300 HB	BNM	JBN245	$n(\text{min}^{-1})$	19,890	15,920	12,730	10,610
			$V_f(\text{mm}/\text{min})$	7,960	7,960	6,370	6,370
			$a_p(\text{mm})$	0.05	0.05	0.05	0.05
			$a_e(\text{mm})$	0.25	0.3	0.4	0.5

Note

1. These cutting conditions represent on high speed machine.
2. These cutting conditions represent stable machining at length $3 \times D_c$.
Please adjust cutting conditions according to overhang length.
3. Use carbide shank holder.
4. For better surface finish , mist coolant is recommended.
5. Plunging is not recommended.
- 6 Please keep the stock uniform by pre-machining.

Overhang length l/D_c	n (min^{-1})	V_f (mm/min)
$\sim 3D_c$	100%	100%
$3D_c \sim 5D_c$	70%	70%
$5D_c \sim 10D_c$	50%	50%

MIRROR RADIUS

RNM Type

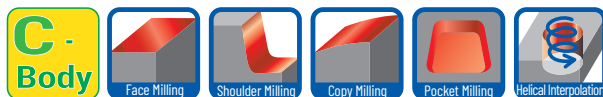

RNM
TYPE

Shank Type

High Precision Indexable Radius End Mill

● Corner radius accuracy below $\pm 0.010\text{mm}$

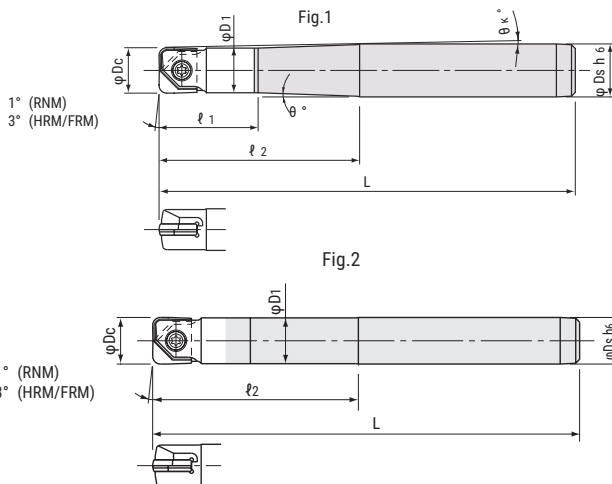

Cat.No.	Stock	Dimensions (mm)							Parts		Inserts	Fig.	
		ϕD_c	ℓ_1	ℓ_2	L	ϕD_1	θ°	θ_k	ϕD_s	Screws			Wrench
RNMS-060015U-S06C	●	6		15	60	5.7			6	FSW-2005H	A-06	RNM-060 HRM-060 FRM-060	2
RNMM-060030U-S06C	●			30	80								
RNMS-080020U-S08C	●	8		20	70	7.6			8	FSW-2506H	A-07	RNM-080 HRM-080/090 FRM-080	1
RNMM-080040U-S08C	●			40	90								
RNMM-080053T-S12C	●			20	53	110			7.8	2°	2°12'	12	
RNML-080075S-S08C	●				75	140			8				
RNMS-100025U-S10C	●	10		25	75	9.5			10	FSW-3007H	A-08	RNM-100 HRM-100/110 FRM-100	2
RNMM-100050U-S10C	●			50	100								
RNMM-100050S-S10C	●			22.5	53	110			9.8	1°	1°7'	12	
RNMM-100053T-S12C	●				75	140			10				
RNMS-120030U-S12C	●	12		30	80	11.5			12	FSW-3509H	A-10	RNM-120 HRM-120/130 FRM-120	2
RNMM-120060U-S12C	●			60	110								
RNMM-120053S-S12C	●			95	53	110			11.8				
RNML-120095S-S12C	●				160								
RNMS-160035U-S16C	●	16		35	90	15.5			16	FSW-4013H	A-15	RNM-160 HRM-160/170 FRM-160	2
RNMM-160070S-S16C	●			70	140								
RNMM-160090S-S16C	●			120	90	160			15.8				
RNML-160120S-S16C	●				210								
RNML-160150S-S16C	●				220								

Screw	Torque (N.m)
FSW-2005H	0.5
FSW-2506H	0.9
FSW-3007H	1.2
FSW-3509H	2.0
FSW-4013H	3.0

MIRROR RADIUS **RNM Type**

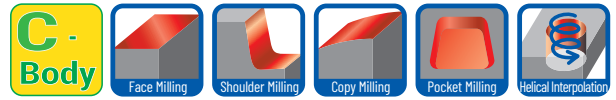

RNM
TYPE

Shank Type
High Precision Indexable Radius End Mill

- Corner radius accuracy **below ±0.010mm**

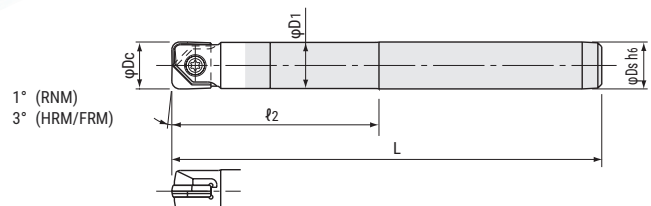

Fig 2

Cat.No.	Stock	Dimensions (mm)					Parts		Inserts	Fig.	
		φDc	ℓ2	L	φD1	φDs	Screws	Wrench			
RNMS-200040U-S20C	●	20	40	105	19.5	19.8	20	FSW-5016H	A-20W	RNM-200 HRM-200/220 FRM-200/210	2
RNMM-200075S-S20C	●		75	141							
RNMM-200105S-S20C	●		105	180							
RNML-200150S-S20C	●		150	220							
RNML-200170S-S20C	●		170	250							
RNMM-250090S-S25C	●	25	90	166	24.8	25	FSW-6020	A-30	RNM-250 FRM-250/260		
RNMM-250140S-S25C	●		140	220							
RNML-250190S-S25C	●		190	260							
RNMM-300106S-S32C	●	30	106	186	29.8	32	FSW-8025S	A-30	RNM-300 FRM-300		
RNMM-320106S-S32C	●	32			31.8						

Screw	Torque (N.m)
FSW-5016H	4.0
FSW-6020	5.0
FSW-8025S	6.0

MIRROR RADIUS

MRX Type

MRX
TYPE

Modular Type

High Precision Indexable Radius End Mill

Through
coolant
hole

- RNM / Corner radius accuracy **below $\pm 0.010\text{mm}$**
- HRM / Corner radius accuracy **$\pm 0.015\text{ mm}$**
- FRM / Corner radius accuracy **$\pm 0.010\text{ mm}$**
- O.D. run out / MRX + MSN carbide shank **below $\pm 0.015\text{mm}$**

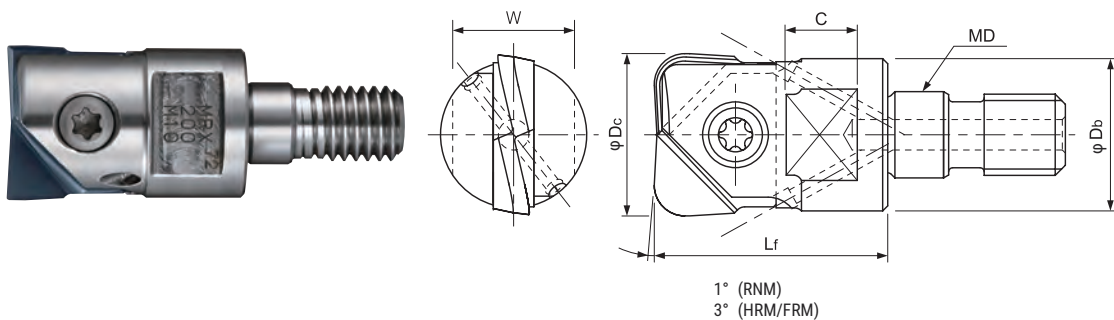

Cat.No.	Stock	Dimensions (mm)					Parts		Inserts	
		ϕD_c	Lf	ϕD_b	MD	C	W	Screws		Wrench
MRX-100-M6	●	10	18	9.7	M6	6.5	8	FSW-3007H	A-08	RNM-100 HRM-100/110 FRM-100...
MRX-120-M6	●	12	20	11.5	M6			FSW-3509H	A-10	RNM-120 HRM-120/130 FRM-120
MRX-160-M8	●	16	23	15	M8	8	12	FSW-4013H	A-15	RNM-160 HRM-160/170 FRM-160/170...
MRX-200-M10	●	20	30	18.5	M10			14	FSW-5016H	A-20W
MRX-250-M12	●	25	35	24	M12	10	17	FSW-6020	A-30	RNM-250 FRM-250
MRX-300-M16	●	30	43	29	M16	12.5	22	FSW-8025S	A-30	RNM-300 FRM-300
MRX-320-M16	●	32		30	M16					RNM-320 FRM-320

Screw	Torque (N.m)
FSW-3007H	1.2
FSW-3509H	2.0
FSW-4013H	3.0
FSW-5016H	4.0
FSW-6020	5.0
FSW-8025S	6.0

■ Spanner

	Cat.No.	MD	Torque	width across flat	Thickness	Length
	DS-08	M6	8.0 N.m	12	4	85
	DS-12	M8	16 N.m	12	4	93

MIRROR RADIUS

RNM/MRX Type

Corner radius accuracy
±0.010 mm

RNM
TYPE

Neutral geometry

good for finishing non-ferrous materials such as Aluminium, Copper

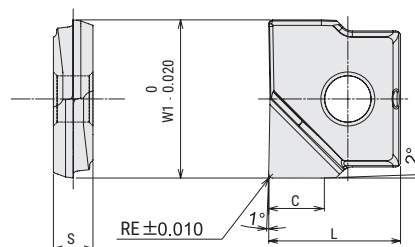
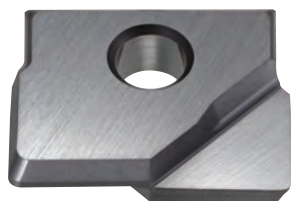

Cat.No.	Coating		Dimensions(mm)				
	Diamond Coating JC10000	Uncoated KT9 (K10)	RE	L	W1	S	C
RNM-080-R03		○	0.3	7	8	2.4	2.7
RNM-080-R05	●	●	0.5				
RNM-080-R10	○	●	1				
RNM-100-R03		○	0.3	8.5	10	2.6	3.3
RNM-100-R05	●	●	0.5				
RNM-100-R10	○	●	1				
RNM-100-R15		○	1.5				
RNM-100-R20		○	2				
RNM-120-R03		○	0.3	10	12	3	4
RNM-120-R05	○	●	0.5				
RNM-120-R10	○	●	1				
RNM-120-R15		○	1.5				
RNM-120-R20		●	2				
RNM-160-R03		●	0.3	12	16	4	5.3
RNM-160-R05		●	0.5				
RNM-160-R10		●	1				
RNM-160-R15		○	1.5				
RNM-160-R20		○	2				
RNM-200-R03		○	0.3	15	20	5	6.7
RNM-200-R05		○	0.5				
RNM-200-R10		●	1				
RNM-200-R15		○	1.5				
RNM-200-R20		○	2				

MIRROR RADIUS

RNM/MRX Type

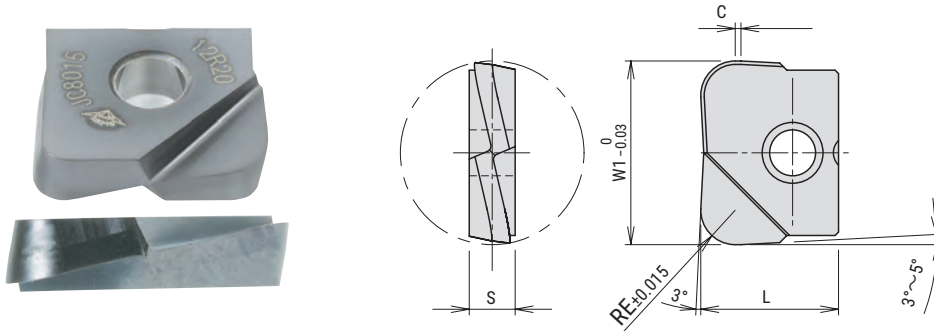
Corner radius accuracy
 ± 0.015 mmHRM
TYPEHigh feed geometry
from Semi-finishing to finishing

Cat.No.	PVD Coating	Dimensions(mm)				
	JC8015	RE	L	W1	S	C
HRM-060-R05	●	0.5	5	6	2	-
HRM-060-R10	●	1				
HRM-060-R15	●	1.5				
HRM-080-R20	●	2	7	8	2.4	0.3
HRM-090-R20	●			9		
HRM-100-R20	●			10		
HRM-110-R20	●		8.5	11	2.6	
HRM-120-R20	●			12		
HRM-130-R20	●			13		
HRM-160-R20	●	3	10	16	4	0.5
HRM-160-R30	●			17		
HRM-170-R30	●			12		
HRM-200-R20	●	2	15	20	5	
HRM-200-R30	●			22		
HRM-220-R30	○			3		

Mirror Radius Oversized Insert

Recommended to use oversized insert ※ for increasing side clearance to prevent the damage of shank by sticking chips.

(※) HRM-090-R20, HRM-110-R20, HRM-130-R20,
HRM-170-R30, HRM-220-R30

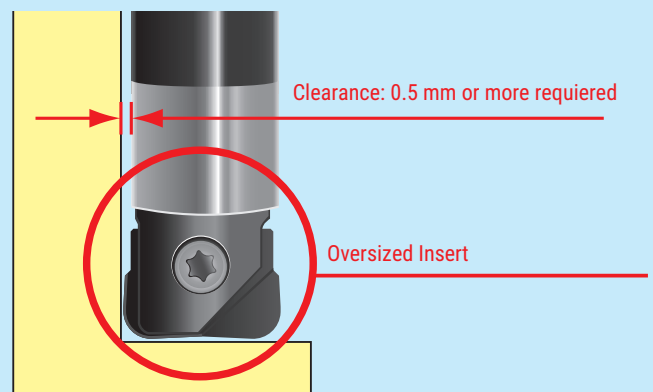

MIRROR RADIUS

RNM/MRX Type

Corner radius accuracy
±0.010 mm

FRM
TYPE

High feed geometry
from Semi-finishing to finishing

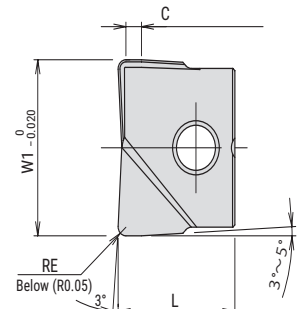
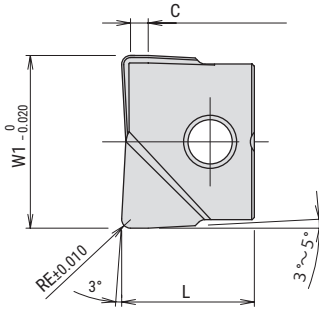
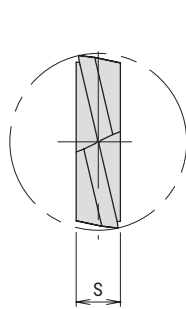
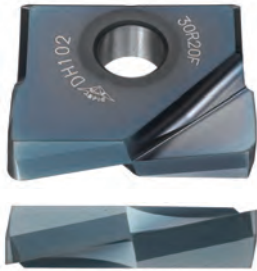

FRM-□□□-R0

Cat.No.	PVD Coating		Dimensions(mm)				
	DH102	JC8015	RE	L	W1	S	C
FRM-060-R0		●	※	5	6	2	0.8
FRM-060-R03	●	◎	0.3				
FRM-060-R05	●	●	0.5				
FRM-060-R10	●	●	1				
FRM-080-R0		●	※	7	8	2.4	1.2
FRM-080-R03	●	●	0.3				
FRM-080-R05	●	●	0.5				
FRM-080-R10	●	●	1				
FRM-100-R0		●	※	8.5	10	2.6	1.5
FRM-100-R03	●	◎	0.3				
FRM-100-R05	●	●	0.5				
FRM-100-R10	●	●	1				
FRM-100-R20	●	●	2	10	12	3	1.5
FRM-120-R0		●	※				
FRM-120-R03	●	●	0.3				
FRM-120-R05	●	●	0.5				
FRM-120-R10	●	●	1	10	13	3	1.5
FRM-120-R15	◎		1.5				
FRM-120-R20	●	●	2				
FRM-120-R30	●		3				
FRM-130-R05		◎	0.5	12	16	4	2
FRM-130-R10		◎	1				
FRM-160-R0		●	※				
FRM-160-R03	●	●	0.3				
FRM-160-R05	●	●	0.5	12	17	4	2
FRM-160-R10	●	●	1				
FRM-160-R15	●		1.5				
FRM-160-R20	●	●	2				
FRM-160-R30	●		3	12	17	4	2
FRM-170-R03		◎	0.3				
FRM-170-R05		◎	0.5				
FRM-170-R10	●	●	1				
FRM-170-R20		◎	2				

Cat.No.	PVD Coating		Dimensions(mm)				
	DH102	JC8015	RE	L	W1	S	C
FRM-200-R0		●	※	15	20	5	2
FRM-200-R03	●	◎	0.3				
FRM-200-R05	●	●	0.5				
FRM-200-R10	●	●	1				
FRM-200-R15	●		1.5	15	21	5	2
FRM-200-R20	●	●	2				
FRM-200-R30	●	◎	3				
FRM-210-R05		◎	0.5				
FRM-210-R10	●	●	1	18.5	25	6	2.5
FRM-210-R20		◎	2				
FRM-250-R03	●	●	0.3				
FRM-250-R05	●	●	0.5				
FRM-250-R10	●	●	1	18.5	26	6	2.5
FRM-250-R15	◎		1.5				
FRM-250-R20	●	●	2				
FRM-250-R30	●	●	3				
FRM-260-R03		◎	0.3	22.5	30	7	3
FRM-260-R05		◎	0.5				
FRM-260-R10		◎	1				
FRM-300-R03	○	○	0.3				
FRM-300-R05	○	○	0.5	23.5	32	7	3
FRM-300-R10	○	○	1				
FRM-300-R20	○	○	2				
FRM-300-R30	○	○	3				
FRM-320-R03	●	●	0.3	23.5	32	7	3
FRM-320-R05	●	●	0.5				
FRM-320-R10	●	●	1				
FRM-320-R20	●	●	2				
FRM-320-R30	●		3				

MIRROR RADIUS

RNM/MRX Type

■ Grade Selection Guide

Material	Insert	Grade	RNM		HRM	FRM	
			JC10000	KT9	JC8015	DH102	JC8015
Carbon steel below 250HB	FRM HRM	JC8015			◎		◎
Cast steel below 285HB	FRM HRM	JC8015			◎		◎
Tool & Die steel below 255HB	FRM HRM	JC8015			◎		◎
Mold steel 30 - 36HRC	FRM HRM	JC8015			◎		◎
Mold steel 38 - 43HRC	FRM HRM	JC8015			◎		◎
Hardened die steel 42 - 52HRC	FRM HRM	DH102 JC8015			○	◎	○
Hardened die steel 55 - 62HRC	FRM	DH102				◎	
HSS 63 - 70HRC	FRM	DH102				◎	
Grey & Nodular cast iron below 300HB	FRM HRM	DH102 JC8015			○	◎	○
Austenitic stainless steel (304,316,317) 17Cr	FRM HRM	JC8015			◎	○	◎
Aluminium alloy (A5052)	RNM	KT9		◎			
Copper alloy (C1100)	RNM	KT9		◎			
Graphite	RNM	JC10000	◎				
Titanium alloy (Ti-6Al-4V) 35 - 43HRC	HRM FRM	JC8015			◎		◎
Heat resistant alloy (INCO718) 35 - 43HRC	HRM FRM	JC8015			◎		◎

MIRROR RADIUS

RNM/MRX Type

■ Recommended Cutting Conditions - Side Finishing

Material	Cat.No	Grade		Tool dia.(mm)								
				6	8	10	12/13	16/17	20/21	25/26	30	32
Carbon steel below 250HB	FRM HRM	JC8015	n(min ⁻¹)	15,920	11,940	9,550	7,960	5,970	4,770	3,820	3,180	2,980
			Vf(mm/min)	3,980	2,990	2,870	2,390	2,390	1,910	1,530	1,270	1,190
			ap(mm)	0.2	0.3	0.3	0.3	0.4	0.5	0.8	1.0	1.2
			ae(mm)	0.1	0.1	0.1	0.1	0.1	0.1	0.1	0.1	0.1
Cast steel below 285HB	FRM HRM	JC8015	n(min ⁻¹)	15,920	11,940	9,550	7,960	5,970	4,770	3,820	3,180	2,980
			Vf(mm/min)	3,980	2,990	2,870	2,390	2,390	1,910	1,530	1,270	1,190
			ap(mm)	0.2	0.3	0.3	0.3	0.4	0.5	0.8	1.0	1.2
			ae(mm)	0.1	0.1	0.1	0.1	0.1	0.1	0.1	0.1	0.1
Tool & Die steel below 255HB	FRM HRM	JC8015	n(min ⁻¹)	15,920	11,940	9,550	7,960	5,970	4,770	3,820	3,180	2,980
			Vf(mm/min)	3,980	2,990	2,870	2,390	2,390	1,910	1,530	1,270	1,190
			ap(mm)	0.2	0.3	0.3	0.3	0.4	0.5	0.8	1.0	1.2
			ae(mm)	0.1	0.1	0.1	0.1	0.1	0.1	0.1	0.1	0.1
Mold steel 30 - 36HRC	FRM HRM	JC8015	n(min ⁻¹)	15,920	11,940	9,550	7,960	5,970	4,770	3,820	3,180	2,980
			Vf(mm/min)	3,980	2,990	2,870	2,390	2,390	1,910	1,530	1,270	1,190
			ap(mm)	0.2	0.3	0.3	0.3	0.4	0.5	0.8	1.0	1.2
			ae(mm)	0.1	0.1	0.1	0.1	0.1	0.1	0.1	0.1	0.1
Mold steel 38 - 43HRC	FRM HRM	JC8015	n(min ⁻¹)	14,850	11,140	8,910	7,430	5,570	4,460	3,570	2,970	2,790
			Vf(mm/min)	3,710	2,790	2,670	2,230	1,670	1,340	1,070	890	840
			ap(mm)	0.2	0.2	0.3	0.3	0.4	0.5	0.8	1.0	1.2
			ae(mm)	0.1	0.1	0.1	0.1	0.1	0.1	0.1	0.1	0.1
Hardened die steel 42 - 52HRC	FRM HRM	DH102 JC8015	n(min ⁻¹)	13,260	9,950	7,960	6,630	4,970	3,980	3,180	2,650	2,490
			Vf(mm/min)	1,330	1,000	800	660	750	600	480	400	370
			ap(mm)	0.2	0.2	0.3	0.3	0.4	0.5	0.6	0.8	1.0
			ae(mm)	0.1	0.1	0.1	0.1	0.1	0.1	0.1	0.1	0.1
Hardened die steel 55 - 62HRC	FRM	DH102	n(min ⁻¹)	10,610	7,960	6,370	5,310	3,980	3,180	2,550	2,120	1,990
			Vf(mm/min)	1,060	800	640	530	600	480	380	320	300
			ap(mm)	0.2	0.2	0.3	0.3	0.4	0.5	0.6	0.8	1.0
			ae(mm)	0.1	0.1	0.1	0.1	0.1	0.1	0.1	0.1	0.1
HSS 63 - 70HRC	FRM	DH102	n(min ⁻¹)	7,960	5,970	4,770	3,980	2,980	2,390	1,910	1,590	1,490
			Vf(mm/min)	320	240	290	320	300	240	190	160	150
			ap(mm)	0.1	0.1	0.1	0.1	0.2	0.2	0.3	0.4	0.5
			ae(mm)	0.1	0.1	0.1	0.1	0.1	0.1	0.1	0.1	0.1
Grey & Nodular cast iron below 300 HB	FRM HRM	DH102 JC8015	n(min ⁻¹)	18,570	13,930	11,140	9,280	6,960	5,570	4,460	3,710	3,480
			Vf(mm/min)	6,500	4,880	3,900	3,250	3,480	3,340	2,680	2,230	2,090
			ap(mm)	0.2	0.3	0.3	0.3	0.4	0.5	0.8	1.0	1.2
			ae(mm)	0.1	0.1	0.2	0.2	0.2	0.2	0.2	0.2	0.2
Stainless steel	FRM HRM	JC8015	n(min ⁻¹)	14,850	11,140	8,910	7,430	5,570	4,460	3,570	2,970	2,790
			Vf(mm/min)	4,460	3,340	2,670	2,230	2,230	1,780	1,430	1,190	1,120
			ap(mm)	0.2	0.3	0.3	0.3	0.4	0.5	0.8	1.0	1.0
			ae(mm)	0.1	0.1	0.1	0.1	0.1	0.1	0.1	0.1	0.1
Aluminium	RNM	KT9	n(min ⁻¹)	18,570	13,930	11,140	9,280	6,960	5,570	4,460	3,710	3,480
			Vf(mm/min)	7,430	5,570	4,460	3,710	3,500	2,800	2,230	1,860	1,740
			ap(mm)	0.3	0.4	0.5	0.6	0.8	1.0	1.2	1.6	1.6
			ae(mm)	0.2	0.2	0.2	0.2	0.2	0.2	0.2	0.2	0.2
Copper alloy	RNM	KT9	n(min ⁻¹)	13,260	9,950	7,960	6,630	4,970	3,980	3,180	2,650	2,490
			Vf(mm/min)	5,300	3,980	3,180	2,650	2,500	2,000	1,590	1,330	1,250
			ap(mm)	0.2	0.3	0.3	0.4	0.5	0.7	0.8	1.0	1.0
			ae(mm)	0.15	0.15	0.15	0.15	0.15	0.15	0.15	0.15	0.15
Graphite	RNM	JC10000	n(min ⁻¹)	18,570	13,930	11,140	9,280	6,960	5,570	4,460	3,710	3,480
			Vf(mm/min)	7,430	5,570	4,460	3,710	3,500	2,800	2,230	1,860	1,740
			ap(mm)	0.3	0.4	0.5	0.6	0.8	1.0	1.2	1.6	1.6
			ae(mm)	0.2	0.2	0.2	0.2	0.2	0.2	0.2	0.2	0.2
Titanium alloy (Ti-6Al-4V)	HRM FRM	JC8015	n(min ⁻¹)	5,310	3,980	3,180	2,650	1,990	1,590	1,270	1,060	990
			Vf(mm/min)	1,060	800	760	640	480	380	320	270	250
			ap(mm)	0.2	0.2	0.3	0.3	0.3	0.3	0.4	0.4	0.4
			ae(mm)	0.1	0.1	0.1	0.1	0.1	0.1	0.1	0.1	0.1
Heat resistant alloy (INC0718)	HRM FRM	JC8015	n(min ⁻¹)	4,240	3,180	2,550	2,120	1,590	1,270	1,020	850	800
			Vf(mm/min)	850	640	610	510	380	300	260	210	200
			ap(mm)	0.2	0.2	0.3	0.3	0.3	0.3	0.4	0.4	0.4
			ae(mm)	0.1	0.1	0.1	0.1	0.1	0.1	0.1	0.1	0.1

- Note) 1. Please adjust cutting conditions according to machine rigidity or work rigidity.
2. These cutting conditions represent stable machining at length 3 x Dc.
Please adjust cutting conditions according to overhang length.
3. In case of chatter occurring, recommended to reduce ap or feed.
4. Use air blow.

Overhang length l/Dc	n (min ⁻¹)	Vf (mm/min)
~3Dc	100%	100%
3Dc~5Dc	70%	70%
5Dc~10Dc	50%	50%

MIRROR RADIUS

RNM/MRX Type

■ Recommended Cutting Conditions - Bottom Finishing

Material	Cat.No	Grade		Tool dia.(mm)								
				6	8	10	12/13	16/17	20/21	25/26	30	32
Carbon steel below 250HB	FRM HRM	JC8015	$n(\text{min}^{-1})$	13,790	10,350	8,280	6,900	5,170	4,140	3,310	2,760	2,590
			$V_f(\text{mm/min})$	3,450	3,110	2,480	2,070	2,070	1,660	1,320	1,100	1,040
			$ap(\text{mm})$	0.1	0.15	0.15	0.15	0.15	0.2	0.2	0.2	0.2
			$ae(\text{mm})$	1.0(~3)	1.2(~4)	1.2(~5)	1.5(~5)	2.0(~9)	2.5(~13)	4.0(~18)	4.2(~23)	4.2(~25)
Cast steel below 285HB	FRM HRM	JC8015	$n(\text{min}^{-1})$	13,790	10,350	8,280	6,900	5,170	4,140	3,310	2,760	2,590
			$V_f(\text{mm/min})$	3,450	3,110	2,480	2,070	2,070	1,660	1,320	1,100	1,040
			$ap(\text{mm})$	0.1	0.15	0.15	0.15	0.15	0.2	0.2	0.2	0.2
			$ae(\text{mm})$	1.0(~3)	1.2(~4)	1.2(~5)	1.5(~5)	2.0(~9)	2.5(~13)	4.0(~18)	4.2(~23)	4.2(~25)
Tool & Die steel below 255HB	FRM HRM	JC8015	$n(\text{min}^{-1})$	13,790	10,350	8,280	6,900	5,170	4,140	3,310	2,760	2,590
			$V_f(\text{mm/min})$	3,450	3,110	2,480	2,070	2,070	1,660	1,320	1,100	1,040
			$ap(\text{mm})$	0.1	0.15	0.15	0.15	0.15	0.2	0.2	0.2	0.2
			$ae(\text{mm})$	1.0(~3)	1.2(~4)	1.2(~5)	1.5(~5)	2.0(~9)	2.5(~13)	4.0(~18)	4.2(~23)	4.2(~25)
Mold steel 30 - 36HRC	FRM HRM	JC8015	$n(\text{min}^{-1})$	13,790	10,350	8,280	6,900	5,170	4,140	3,310	2,760	2,590
			$V_f(\text{mm/min})$	3,450	3,110	2,480	2,070	2,070	1,660	1,320	1,100	1,040
			$ap(\text{mm})$	0.1	0.15	0.15	0.15	0.15	0.2	0.2	0.2	0.2
			$ae(\text{mm})$	1.0(~3)	1.2(~4)	1.2(~5)	1.5(~5)	2.0(~9)	2.5(~13)	4.0(~18)	4.2(~23)	4.2(~25)
Mold steel 38 - 43HRC	FRM HRM	JC8015	$n(\text{min}^{-1})$	12,730	9,550	7,640	6,370	4,770	3,820	3,060	2,550	2,390
			$V_f(\text{mm/min})$	3,180	2,870	2,290	1,910	1,430	1,150	920	770	720
			$ap(\text{mm})$	0.1	0.15	0.15	0.15	0.15	0.2	0.2	0.2	0.2
			$ae(\text{mm})$	1.0(~3)	1.2(~4)	1.2(~5)	1.5(~5)	2.0(~9)	2.5(~13)	4.0(~18)	4.2(~23)	4.2(~25)
Hardened die steel 42 - 52HRC	FRM HRM	DH102 JC8015	$n(\text{min}^{-1})$	10,080	7,560	6,050	5,040	3,780	3,020	2,420	2,020	1,890
			$V_f(\text{mm/min})$	1,010	760	610	600	570	450	360	300	280
			$ap(\text{mm})$	0.05	0.06	0.08	0.1	0.1	0.15	0.15	0.15	0.15
			$ae(\text{mm})$	1.0(~3)	1.2(~4)	1.2(~5)	1.5(~5)	2.0(~9)	2.5(~13)	4.0(~18)	4.2(~23)	4.2(~25)
Hardened die steel 55 - 62HRC	FRM	DH102	$n(\text{min}^{-1})$	6,900	5,170	4,140	3,450	2,590	2,070	1,660	1,380	1,290
			$V_f(\text{mm/min})$	690	520	410	410	390	310	250	210	190
			$ap(\text{mm})$	0.05	0.06	0.08	0.1	0.1	0.15	0.15	0.15	0.15
			$ae(\text{mm})$	1.0(~3)	1.2(~4)	1.2(~5)	1.5(~5)	2.0(~9)	2.5(~13)	4.0(~18)	4.2(~23)	4.2(~25)
HSS 63 - 70HRC	FRM	DH102	$n(\text{min}^{-1})$	5,310	3,980	3,180	2,650	1,990	1,590	1,270	1,060	990
			$V_f(\text{mm/min})$	210	160	190	210	200	160	130	110	100
			$ap(\text{mm})$	0.03	0.04	0.05	0.05	0.05	0.05	0.05	0.05	0.05
			$ae(\text{mm})$	1.0(~2)	1.2(~3)	1.2(~4)	1.5(~5)	2.0(~6)	2.5(~8)	4.0(~10)	4.2(~12)	4.2(~13)
Grey & Nodular cast iron below 300 HB	FRM HRM	DH102 JC8015	$n(\text{min}^{-1})$	15,920	11,940	9,550	7,960	5,970	4,770	3,820	3,180	2,980
			$V_f(\text{mm/min})$	4,780	4,180	3,340	3,180	2,390	1,910	1,910	1,590	1,490
			$ap(\text{mm})$	0.1	0.15	0.15	0.2	0.2	0.2	0.2	0.2	0.2
			$ae(\text{mm})$	1.0(~3)	1.2(~4)	1.2(~5)	1.5(~5)	2.0(~9)	2.5(~13)	4.0(~18)	4.2(~23)	4.2(~25)
Stainless steel	FRM HRM	JC8015	$n(\text{min}^{-1})$	12,730	9,550	7,640	6,370	4,770	3,820	3,060	2,550	2,390
			$V_f(\text{mm/min})$	3,180	2,870	2,290	1,910	1,910	1,530	1,220	1,020	960
			$ap(\text{mm})$	0.1	0.15	0.15	0.15	0.15	0.15	0.15	0.15	0.15
			$ae(\text{mm})$	1.0(~3)	1.2(~4)	1.2(~5)	1.5(~5)	2.0(~9)	2.5(~13)	4.0(~18)	4.2(~23)	4.2(~25)
Aluminium	RNM	KT9	$n(\text{min}^{-1})$	15,920	11,940	9,550	7,960	5,970	4,770	3,820	3,180	2,980
			$V_f(\text{mm/min})$	6,370	4,780	3,820	3,180	3,580	2,860	2,290	1,910	1,790
			$ap(\text{mm})$	0.2	0.25	0.25	0.25	0.25	0.3	0.3	0.3	0.3
			$ae(\text{mm})$	1.0(~3)	1.2(~4)	1.2(~5)	1.5(~5)	2.0(~9)	2.5(~13)	4.0(~18)	4.2(~23)	4.2(~25)
Copper alloy	RNM	KT9	$n(\text{min}^{-1})$	10,610	7,960	6,370	5,310	3,980	3,180	2,550	2,120	1,990
			$V_f(\text{mm/min})$	3,180	2,390	1,910	1,590	1,190	950	770	640	600
			$ap(\text{mm})$	0.15	0.2	0.2	0.2	0.2	0.25	0.25	0.25	0.25
			$ae(\text{mm})$	1.0(~3)	1.2(~4)	1.2(~5)	1.5(~5)	2.0(~9)	2.5(~13)	4.0(~18)	4.2(~23)	4.2(~25)
Graphite	RNM	JC10000	$n(\text{min}^{-1})$	15,920	11,940	9,550	7,960	5,970	4,770	3,820	3,180	2,980
			$V_f(\text{mm/min})$	6,370	4,780	3,820	3,180	3,580	2,860	2,290	1,910	1,790
			$ap(\text{mm})$	0.2	0.25	0.25	0.25	0.25	0.3	0.3	0.3	0.3
			$ae(\text{mm})$	1.0(~3)	1.2(~4)	1.2(~5)	1.5(~5)	2.0(~9)	2.5(~13)	4.0(~18)	4.2(~23)	4.2(~25)
Titanium alloy (Ti-6Al-4V)	HRM FRM	JC8015	$n(\text{min}^{-1})$	2,920	2,190	1,750	1,460	1,090	880	700	580	550
			$V_f(\text{mm/min})$	580	440	350	290	220	180	140	120	110
			$ap(\text{mm})$	0.1	0.15	0.15	0.15	0.15	0.2	0.2	0.2	0.2
			$ae(\text{mm})$	1.0(~3)	1.2(~4)	1.2(~5)	1.5(~5)	2.0(~9)	2.5(~13)	4.0(~18)	4.2(~23)	4.2(~25)
Heat resistant alloy (INCO718)	HRM FRM	JC8015	$n(\text{min}^{-1})$	2,920	2,190	1,750	1,460	1,090	880	700	580	550
			$V_f(\text{mm/min})$	580	440	350	290	220	180	140	120	110
			$ap(\text{mm})$	0.1	0.15	0.15	0.15	0.15	0.2	0.2	0.2	0.2
			$ae(\text{mm})$	1.0(~3)	1.2(~5)	1.2(~5)	1.5(~5)	2.0(~9)	2.5(~13)	4.0(~18)	4.2(~23)	4.2(~25)

Note) 1. Please adjust cutting conditions according to machine rigidity or work rigidity.

2. These cutting conditions represent stable machining at length 3 x Dc.

Please adjust cutting conditions according to overhang length.

3. In case of chatter occurring, recommended to reduce ap or feed.

4. Use air blow.

Overhang length l/Dc	n (min^{-1})	V_f (mm/min)
~3Dc	100%	100%
3Dc~5Dc	70%	70%
5Dc~10Dc	50%	50%

MIRROR RADIUS

RNM/MRX Type

■ Recommended Cutting Conditions - <HRM type> High Feed / Semi finishing

Material		Tool dia.(mm)									
		φ6×R1.5		φ8×R2/φ9×R2				φ10×R2/φ11×R2			
		2.5 D	5.0 D	2.5 D	5.0 D	7.5 D	10 D	2.5 D	5.0 D	7.5 D	10 D
Carbon steel below 250HB	n(min ⁻¹)	9,000	9,000	7,500	7,500	7,500	7,500	6,000	6,000	6,000	6,000
	Vf(mm/min)	8,000	7,200	8,200	6,750	6,750	6,750	7,200	6,000	6,000	6,000
	ap(mm)	0.2	0.15	0.4	0.4	0.25	0.2	0.4	0.4	0.25	0.2
	ae(mm)	2.1	2.1	2.8	2.8	2.8	2.8	4.2	4.2	4.2	4.2
Mold steel 30 - 43HRC	n(min ⁻¹)	8,500	8,500	7,100	7,100	7,100	7,100	5,700	5,700	5,700	5,700
	Vf(mm/min)	7,600	6,800	7,800	6,400	6,400	6,400	6,800	5,700	5,700	5,700
	ap(mm)	0.2	0.15	0.4	0.4	0.25	0.2	0.4	0.4	0.25	0.2
	ae(mm)	2.1	2.1	2.8	2.8	2.8	2.8	4.2	4.2	4.2	4.2
Tool & Die steel below 255HB	n(min ⁻¹)	8,500	8,500	7,100	7,100	7,100	7,100	5,700	5,700	5,700	5,700
	Vf(mm/min)	7,600	6,800	7,800	6,400	6,400	6,400	6,800	5,700	5,700	5,700
	ap(mm)	0.2	0.15	0.4	0.4	0.25	0.2	0.4	0.4	0.25	0.2
	ae(mm)	2.1	2.1	2.8	2.8	2.8	2.8	4.2	4.2	4.2	4.2
Stainless steel below 250HB	n(min ⁻¹)	8,000	8,000	6,700	6,700	6,700	6,700	5,400	5,400	5,400	5,400
	Vf(mm/min)	6,400	5,600	7,300	6,000	6,000	6,000	6,400	5,400	5,400	5,400
	ap(mm)	0.2	0.15	0.4	0.4	0.25	0.2	0.4	0.4	0.25	0.2
	ae(mm)	2.1	2.1	2.8	2.8	2.8	2.8	4.2	4.2	4.2	4.2
Hardened die steel 40 - 50HRC	n(min ⁻¹)	6,900	6,900	6,000	6,000	6,000	6,000	4,700	4,700	4,700	4,700
	Vf(mm/min)	5,500	4,800	6,600	4,800	4,800	4,800	5,600	4,700	4,700	4,700
	ap(mm)	0.15	0.1	0.2	0.2	0.15	0.1	0.2	0.2	0.15	0.1
	ae(mm)	2.1	2.1	2.8	2.8	2.8	2.8	4.2	4.2	4.2	4.2
Grey & Nodular cast iron below 300 HB	n(min ⁻¹)	7,400	7,400	6,400	6,400	6,400	6,400	5,100	5,100	5,100	5,100
	Vf(mm/min)	6,600	5,900	7,600	5,700	5,700	5,700	6,100	5,100	5,100	5,100
	ap(mm)	0.2	0.15	0.4	0.4	0.25	0.2	0.4	0.4	0.25	0.2
	ae(mm)	2.1	2.1	2.8	2.8	2.8	2.8	4.2	4.2	4.2	4.2

ap adjustment by corner radius ap × ratio	Tool dia.(mm)	ap(mm)
	φ6×R0.5	65%
	φ6×R1.0	80%
	φ6×R1.5	100%

- Note) 1. Please adjust cutting conditions according to machine rigidity or work rigidity.
 2. In case of chatter occurring, recommended to reduce ap or Vf.
 3. Recommended to reduce the parameters when using on low horse power machine.
 4. Use air blow.
 5. Reduce ap, n & Vf by 30% in case of cutting material 50-55HRC.
 6. Reduce Vf for better surface finish.
 7. Use angle 2°30' or below in case of ramping (see right figure).
 8. In case of slotting with over 5xDc, reduce Vf or ap appropriately.

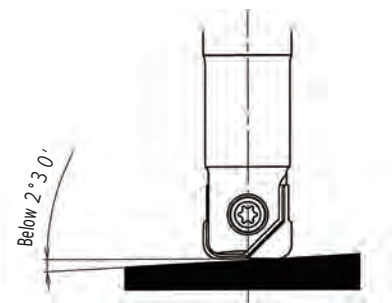

★ Insert Mounting Information

1. Make sure the insert seat on body is carefully cleaned.
2. Make sure insert itself is clean, especially the hole and face location.
3. Change insert screw when threads starts to wear.
4. Do not over tighten screw. See table for torque specifications.

Toll dia. (mm)	Torque
φDc	N·m
6	0.5
8	0.9
10	1.2
12	2.0
16	3.0
20	4.0

MIRROR RADIUS

RNM/MRX Type

■ Recommended Cutting Conditions - <HRM type>High Feed / Semi finishing

Material		Tool dia.(mm)											
		φ12×R2/φ13×R2				φ16×R3/φ17×R3				φ20×R3/φ22×R3			
		2.5 D	5.0 D	7.5 D	10 D	2.5 D	5.0 D	7.5 D	10 D	2.5 D	5.0 D	7.5 D	10 D
Carbon steel below 250HB	$n(\text{min}^{-1})$	5,000	5,000	5,000	5,000	3,800	3,800	3,800	3,800	3,000	3,000	3,000	3,000
	$V_f(\text{mm/min})$	6,000	5,000	5,000	5,000	4,500	3,800	3,800	3,800	3,600	3,000	3,000	3,000
	$a_p(\text{mm})$	0.5	0.4	0.25	0.2	0.6	0.6	0.4	0.3	0.6	0.6	0.4	0.3
	$a_e(\text{mm})$	5.6	5.6	5.6	5.6	7	7	7	7	9.8	9.8	9.8	9.8
Mold steel 30 - 43HRC	$n(\text{min}^{-1})$	4,700	4,700	4,700	4,700	3,500	3,500	3,500	3,500	2,800	2,800	2,800	2,800
	$V_f(\text{mm/min})$	5,600	4,700	4,700	4,700	4,200	3,500	3,500	3,500	3,300	2,800	2,800	2,800
	$a_p(\text{mm})$	0.4	0.4	0.25	0.2	0.6	0.6	0.4	0.3	0.6	0.6	0.4	0.3
	$a_e(\text{mm})$	5.6	5.6	5.6	5.6	7	7	7	7	9.8	9.8	9.8	9.8
Tool & Die steel below 255HB	$n(\text{min}^{-1})$	4,700	4,700	4,700	4,700	3,500	3,500	3,500	3,500	2,800	2,800	2,800	2,800
	$V_f(\text{mm/min})$	5,600	4,700	4,700	4,700	4,200	3,500	3,500	3,500	3,300	2,800	2,800	2,800
	$a_p(\text{mm})$	0.4	0.4	0.25	0.2	0.6	0.6	0.4	0.3	0.6	0.6	0.4	0.3
	$a_e(\text{mm})$	5.6	5.6	5.6	5.6	7	7	7	7	9.8	9.8	9.8	9.8
Stainless steel below 250HB	$n(\text{min}^{-1})$	4,500	4,500	4,500	4,500	3,400	3,400	3,400	3,400	2,700	2,700	2,700	2,700
	$V_f(\text{mm/min})$	5,400	4,500	4,500	4,500	4,000	3,400	3,400	3,400	3,200	2,700	2,700	2,700
	$a_p(\text{mm})$	0.4	0.4	0.25	0.2	0.6	0.6	0.4	0.3	0.6	0.6	0.4	0.3
	$a_e(\text{mm})$	5.6	5.6	5.6	5.6	7	7	7	7	9.8	9.8	9.8	9.8
Hardened die steel 40 - 50HRC	$n(\text{min}^{-1})$	4,000	4,000	4,000	4,000	3,000	3,000	3,000	3,000	2,400	2,400	2,400	2,400
	$V_f(\text{mm/min})$	4,800	4,000	4,000	4,000	3,600	3,000	3,000	3,000	2,800	2,400	2,400	2,400
	$a_p(\text{mm})$	0.2	0.2	0.15	0.1	0.3	0.3	0.25	0.2	0.3	0.3	0.25	0.2
	$a_e(\text{mm})$	5.6	5.6	5.6	5.6	7	7	7	7	9.8	9.8	9.8	9.8
Grey & Nodular cast iron below 300 HB	$n(\text{min}^{-1})$	4,200	4,200	4,200	4,200	3,200	3,200	3,200	3,200	2,500	2,500	2,500	2,500
	$V_f(\text{mm/min})$	5,000	4,200	4,200	4,200	3,800	3,200	3,200	3,200	3,000	2,500	2,500	2,500
	$a_p(\text{mm})$	0.4	0.4	0.25	0.2	0.6	0.6	0.4	0.3	0.6	0.6	0.4	0.3
	$a_e(\text{mm})$	5.6	5.6	5.6	5.6	7	7	7	7	9.8	9.8	9.8	9.8
a_p adjustment by corner radius $a_p \times$ ratio		Tool dia.(mm)				$a_p(\text{mm})$		Tool dia.(mm)		$a_p(\text{mm})$			
		φ16×R2.0				75%		φ20×R2.0		75%			
		φ16×R3.0				100%		φ20×R3.0		100%			

- Note) 1. Please adjust cutting conditions according to machine rigidity or work rigidity.
 2. In case of chatter occurring, recommended to reduce a_p or V_f .
 3. Recommended to reduce the parameters when using on low horse power machine.
 4. Use air blow.
 5. Reduce a_p , n & V_f by 30% in case of cutting material 50-55HRC.
 6. Reduce V_f for better surface finish.
 7. Use angle $2^\circ 30'$ or below in case of ramping (see right figure).
 8. In case of slotting with over $5xD_c$, reduce V_f or a_p appropriately.

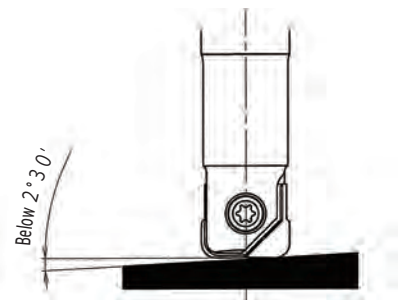

★ Insert Mounting Information

1. Make sure the insert seat on body is carefully cleaned.
2. Make sure insert itself is clean, especially the hole and face location.
3. Change insert screw when threads starts to wear.
4. Do not over tighten screw. See table for torque specifications.

Tool dia. (mm)	Torque
φDc	N·m
6	0.5
8	0.9
10	1.2
12	2.0
16	3.0
20	4.0

DIEMASTER 5G

Multi-Purpose tool for semi-Finishing , Finishing



Feature 1

Double wiper insert

Wiper for face cutting and for periphery cutting

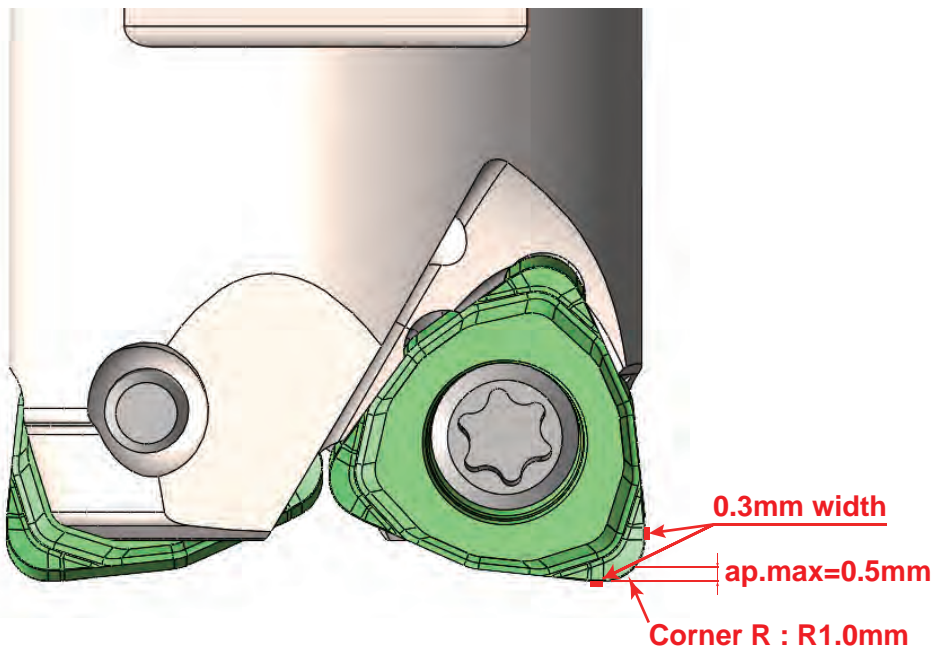

Feature 2

Economical **double-sided** insert (with 6 cutting edges)

High accuracy with H class tolerance

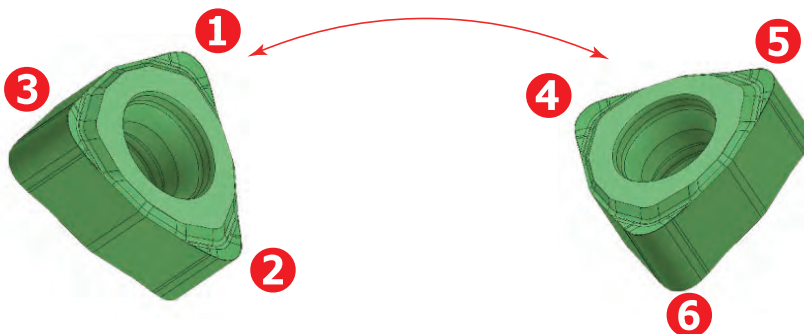

DIEMASTER 5G

MXF/XFG Type

Through coolant hole



XFG
TYPE

Bore Type

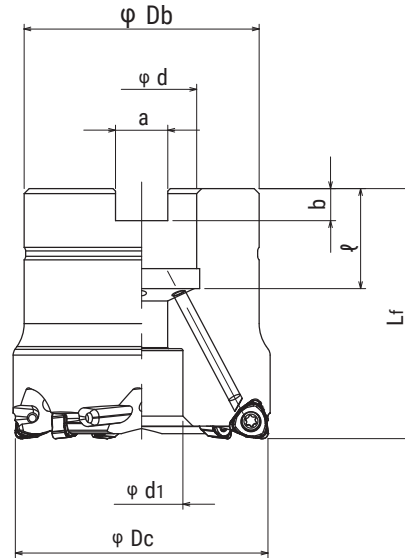

Cat.No.	Stock	No. of inserts	Dimensions (mm)								Arbor set bolt	Weight (kg)	Inserts
			φDc	Lf	φDb	φd	φd1	a	b	ℓ			
XFG-6052R-22	●	6	52	50	47	22	16.5	10.4	6.3	20	M10	0.56	WNHU04T310ZER
XFG-7066R-27	●	7	66	50	48	27	20.0	12.4	7	22	M12×1.75×30★	0.72	

Screw	Torque(N.m)	Wrench
TSW-2567H	1.1	A-08

Through coolant hole

MXF
TYPE

Modular Type

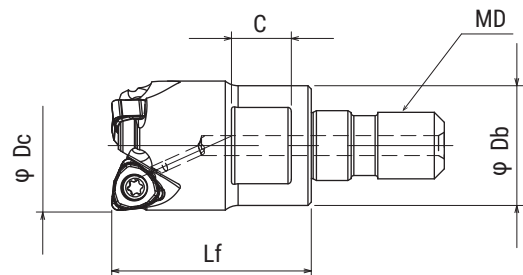
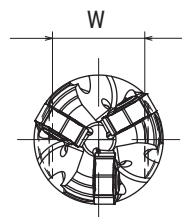

Cat.No.	Stock	No. of inserts	Dimensions (mm)						Insert
			φDc	Lf	φDb	MD	C	W	
MXF-2016-M8	●	2	16	23	14	M8	8	12	WNHU04T310ZER
MXF-3020-M10	●	3	20	30	18	M10	9	14	
MXF-4025-M12	●	4	25	35	22	M12	11	19	
MXF-5035-M16	●	5	35	43	29	M16	12	22	
MXF-6042-M16	●	6	42	43	32	M16	14	26	

Screw	Torque(N.m)	Wrench
TSW-2567H	1.1	A-08

DIEMASTER 5G

MXF/XFG Type

Insert

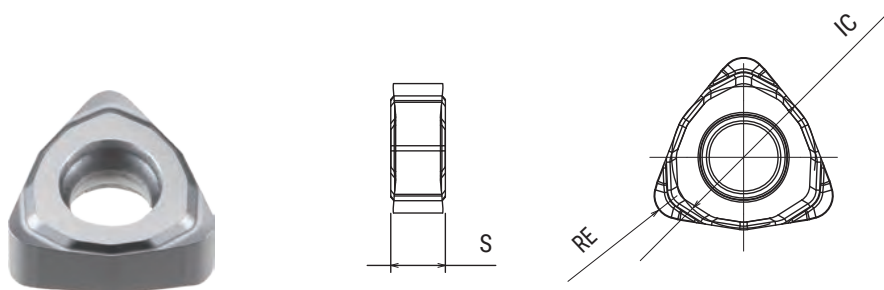

Cat.No.	Tolerance	PVD coated		Dimensions (mm)		
		DH103	JC8015	RE	IC	S
WNHU04T310ZER	H	●	●	1.0	6.35	3.33

DIEMASTER 5G

MXF/XFG Type

● Attention

⚠ Attention to mounting head and MSN/ MGN shank arbor.

■ Tightening procedure

① Cleaning

Remove dirt and chips with air from the connecting thread and face of modular head and MSN/MGN shank arbor

② Initial Tightening

Tighten by hand until the head and the shank arbor faces touch.

③ Final Tightening

Tighten slowly with torque control spanner wrench or DIJET DS type spanner wrench and confirm that there is no gap.

Attention: Final tightening without initial tightening cause connecting thread damage.



NOTE

- Note: 1. Please gently apply pressure on wrench.
2. Please confirm that there is no gap between MSN/MGN shank arbor and modular

Thread	Tightening torque	Spanner size W (mm)
M8	16N · m	12 ☆
M10	16N · m	14, 15
M12	20N · m	17, 19
M16	25N · m	22, 26

- Note: 1. Modular heads are supplied without spanner wrench.
2. In case of choosing torque control spanner wrench, confirm that the wrench size is match to the dimensions W & C of each modular head. (There are some cases that modifying the thickness of spanner wrench is necessary)
3. ☆ mark shows: DIJET have a stock of DS-8 and 12 type spanner wrenches.

⚠ Selection of "MSN Carbide shank arbor"

In case of using modular head over $\varnothing 16\text{mm}$, please select **MSN carbide shank arbor that diameter ($\varnothing D1$) is 1mm or more smaller than modular head ($\varnothing Dc$).**

A wrong selection causes damage to the carbide shank.

$$\varnothing Dc - \varnothing D1 \geq 1\text{mm}$$

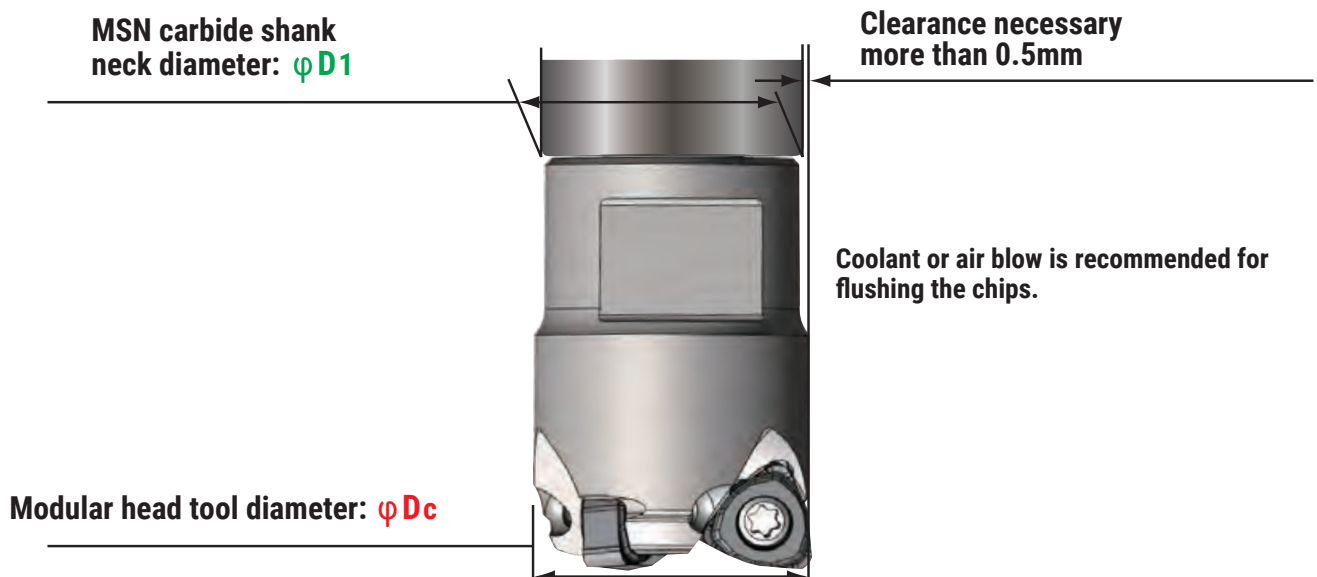

⚠ Caution for the mounting to shrink fit holder.

When you use a carbide shank and a modular head on the shrink fit holder, please shrink fit the only the carbide shank without modular head. **Please mount a modular head after cooling off.**

Note: In case of shrink fit MSN shank + modular head together, it will be difficult to loose due to heat desipation.

DIEMASTER 5G

MXF/XFG Type

Attention for profile milling

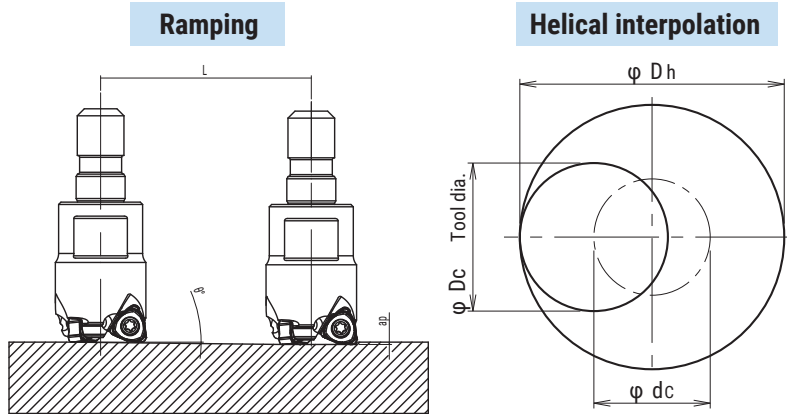

- ⊙ In case of ramping and helical interpolation, apply 80% or less feed speed from standard cutting condition table.
- ⊙ In case of helical interpolation, recommend wet cutting by coolant through the tool.

● Calculation of tool pass dia.

$$\varphi dc = \varphi Dh - \varphi Dc$$

Tool pass dia. Bore dia. Tool dia.

- Depth of cut per one circuit should not exceed max. depth of cut a_p
- Down cutting is recommended, so tool pass rotation should be counterclockwise.
- To obtain a flat bottom surface when helical milling, it requires to remove "the uncut part" in the center of work materials at final pass.

Cat. No.	Tool dia. (mm)	Max. depth of cut (mm)	Ramping		Helical interpolation			
			Max. ramping angle θ°	Total cutting length at Max. a_p	Through hole Min. bore dia. Dh min (mm)	Through hole Max. bore dia. Dh max (mm)	Flat bottom Max. bore dia. Dh min (mm)	
MXF-2016-M8	16	0.5	0.4	72	28.2	31	29.6	
MXF-3020-M10	20	0.5	0.3	95	36.2	39	37.6	
MXF-4025-M12	25	0.5	0.2	143	46.2	49	47.6	
MXF-5035-M16	35	0.5	0.15	191	66.2	69	67.6	
MXF-6042-M16	42	0.5	0.1	286	80.2	83	81.6	
XFG-6052R-22	52	0.5	0.1	286	100.2	103	101.6	
XFG-7066R-27	66	0.5	Ramping & helical interpolation is not recommended.					

※ Drilling is not recommended.

DIEMASTER 5G

MXF/XFG Type

■ Recommended Cutting Conditions

Material	Grade		Finishing		Semi Finishing
			Side Wall	Bottom Face	
Carbon steel below 250HB	JC8015	Vc(mm/min)	300	260	190
		fz(mm/t)	0.20	0.20	0.4 - 0.6
		ap(mm)	0.30	0.20	0.20
		ae(mm)	0.10	~ 0.7 Dc	0.5Dc
Cast steel below 285HB	JC8015	Vc(mm/min)	300	260	190
		fz(mm/t)	0.20	0.20	0.4 - 0.6
		ap(mm)	0.30	0.20	0.20
		ae(mm)	0.10	~ 0.7 Dc	0.5Dc
Tool & die steel below 255HB	JC8015	Vc(mm/min)	300	260	175
		fz(mm/t)	0.20	0.20	0.4 - 0.6
		ap(mm)	0.30	0.20	0.20
		ae(mm)	0.10	~ 0.7 Dc	0.5Dc
Mold steel 30-36 HRC	DH103 JC8015	Vc(mm/min)	300	260	175
		fz(mm/t)	0.20	0.20	0.4 - 0.6
		ap(mm)	0.30	0.20	0.20
		ae(mm)	0.10	~ 0.7 Dc	0.5Dc
Mold steel 38-43HRC	DH103 JC8015	Vc(mm/min)	280	240	160
		fz(mm/t)	0.15	0.15	0.4 - 0.6
		ap(mm)	0.30	0.20	0.20
		ae(mm)	0.10	~ 0.7 Dc	0.5Dc
Hardened die steel 42-52HRC	DH103 JC8015	Vc(mm/min)	250	190	150
		fz(mm/t)	0.08	0.08	0.4 - 0.6
		ap(mm)	0.30	0.15	0.20
		ae(mm)	0.10	~ 0.7 Dc	0.5Dc
Grey cast iron 160-260HB	DH103 JC8015	Vc(mm/min)	350	300	160
		fz(mm/t)	0.25	0.20	0.4 - 0.6
		ap(mm)	0.30	0.20	0.20
		ae(mm)	0.20	~ 0.7 Dc	0.5Dc
Nodular cast iron 170-300HB	DH103 JC8015	Vc(mm/min)	350	300	160
		fz(mm/t)	0.25	0.20	0.4 - 0.6
		ap(mm)	0.30	0.20	0.20
		ae(mm)	0.20	~ 0.7 Dc	0.5Dc
Stainless steel	JC8015	Vc(mm/min)	280	240	170
		fz(mm/t)	0.20	0.20	0.4 - 0.6
		ap(mm)	0.30	0.15	0.20
		ae(mm)	0.10	~ 0.7 Dc	0.5Dc
Titanium alloy Ti-6Al-4V 35-43HRC	JC8015	Vc(mm/min)	100	55	-
		fz(mm/t)	0.12	0.10	-
		ap(mm)	0.25 - 0.30	0.20	-
		ae(mm)	0.10	~ 0.7 Dc	-
Heat resistant alloy INCO718 35-43HRC	JC8015	Vc(mm/min)	80	55	-
		fz(mm/t)	0.12	0.10	-
		ap(mm)	0.25 - 0.30	0.20	-
		ae(mm)	0.10	~ 0.7 Dc	-

Vc : Cutting speed fz : Feed rate per tooth ap : Depth of cut ae : Width of cut

Note

- The above cutting conditions should be adjusted according to the machine rigidity and workpiece rigidity.
- The above cutting conditions are for a overhung length of 3Dc.
Adjust the rotation speed n (min-1) and feed rate Vf (mm/min) according to the protrusion length.
- If chattering occurs, reduce the depth of cut to a shallower depth than the above values or lower the feed rate.
- Remove chips by air blow. Be especially careful when machining cavities with a vertical MC.
- When using a steel shank, reduce the rotation speed n (min-1) and feed rate Vf (mm/min) to 80% of the above conditions.

Recommended Cutting Conditions

Material	Grade		Plunging	
			Finishing	Semi Finishing
Carbon steel below 250HB	JC8015	Vc(mm/min)	400	300
		fz(mm/t)	0.10	0.15
		ae(mm)	~0.2	~2
		Pf(mm)	-	~0.15Dc
Cast steel below 285HB	JC8015	Vc(mm/min)	400	300
		fz(mm/t)	0.10	0.15
		ae(mm)	~0.2	~2
		Pf(mm)	-	~0.15Dc
Tool & die steel below 255HB	JC8015	Vc(mm/min)	350	260
		fz(mm/t)	0.10	0.15
		ae(mm)	~0.2	~2
		Pf(mm)	-	~0.15Dc
Mold steel 30-36 HRC	DH103 JC8015	Vc(mm/min)	300	220
		fz(mm/t)	0.10	0.12
		ae(mm)	~0.2	~2
		Pf(mm)	-	~0.15Dc
Mold steel 38-43HRC	DH103 JC8015	Vc(mm/min)	200	150
		fz(mm/t)	0.10	0.12
		ae(mm)	~0.2	~2
		Pf(mm)	-	~0.15Dc
Hardened die steel 42-52HRC	DH103 JC8015	Vc(mm/min)	140	100
		fz(mm/t)	0.07	0.10
		ae(mm)	~0.2	~2
		Pf(mm)	-	~0.15Dc
Grey cast iron 160-260HB	DH103 JC8015	Vc(mm/min)	500	370
		fz(mm/t)	0.10	0.15
		ae(mm)	~0.2	~2
		Pf(mm)	-	~0.15Dc
Nodular cast iron 170-300HB	DH103 JC8015	Vc(mm/min)	500	370
		fz(mm/t)	0.10	0.15
		ae(mm)	~0.2	~2
		Pf(mm)	-	~0.15Dc

Vc : Cutting speed fz : Feed rate per tooth ae : Width of cut Pf : Pick Feed

Note

1. The above cutting conditions should be adjusted according to the machine rigidity and workpiece rigidity.
2. The above cutting conditions are for a overhung length of 3Dc.
Adjust the rotation speed n (min-1) and feed rate Vf (mm/min) according to the protrusion length.
3. If chattering occurs, reduce the depth of cut to a shallower depth than the above values or lower the feed rate.
4. Remove chips by air blow. Be especially careful when machining cavities with a vertical MC.
5. When using a steel shank, reduce the rotation speed n (min-1) and feed rate Vf (mm/min) to 80% of the above conditions.

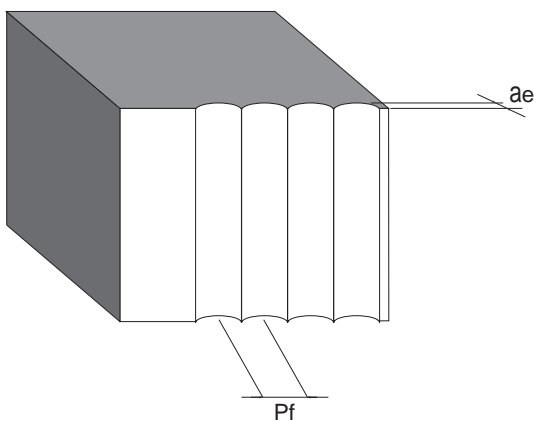

SUPER DIEMASTER

HDM/SDH Type



HDM
TYPE

Bore Type / Standard Pitch
High Efficient Indexable Radius Tool

- High rigidity insert for stable machining.
- Positive axial rake reduces cutting force.

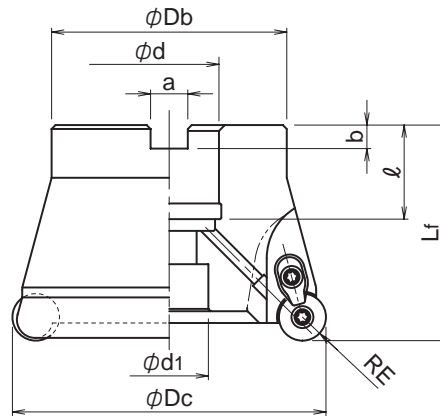

Cat.No.	Stock	No. of inserts	Dimensions(mm)									Arbor set bolt	Parts		Weight (kg)	Inserts
			φDc	RE	Lf	φDb	φd	φd1	a	b	ℓ		Screw	Wrench		
HDM-3050-12R-22	●	3	50	6	50	47	22	16.5	10.4	6.3	20	M10	DSW-410H	A-15T	0.5	RD**1204MO...
HDM-3050-16R-22	●			8	55								DSW-4512H	A-20		RD**1606MO...
HDM-4063-12R-22	●	4	63	6	50	60	22	16.5	10.4	6.3	20	M10	DSW-410H	A-15T	0.7	RD**1204MO...
HDM-4063-16R-22	●			8	55								DSW-4512H	A-20		RD**1606MO...

Screw	Torque (N.m)
DSW-410H	3.6
DSW-4512H	6.0

MD	Hexagonal wrench(mm) for Arbor set bolt
M10	8
M12	10
M16	14
M20	17
M24	19

Inserts	Screw	Clamp	Wrench
RD**1204MO*	DSW-410H	DCM-18	A-15T
RD**1606MO*	DSW-4512H	DCM-17	A-20

SUPER DIEMASTER **HDM/SDH Type**

HDM
TYPE

Bore Type / Fine Pitch

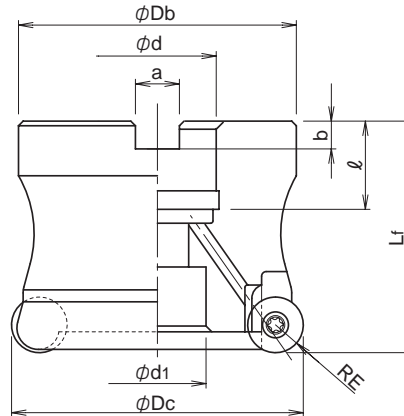

Cat.No.	Stock	No. of inserts	Dimensions(mm)									Arbor set bolt	Weight (kg)	Parts		Inserts
			ϕDc	RE	L_f	ϕDb	ϕd	ϕd_1	a	b	ℓ			Screw	Wrench	
HDM-4050-16R-22	●	4	50	8	55	47	22	16.5	10.4	6.3	20	M10	0.4	DSW-4512H	A-20	RD**1606MO...
HDM-5050-12R-22	●	5		6										40	M10	0.4
HDM-5052-12R-22	●	5	52	6	50	40	27	20	12.4	7	22	M10	0.5	DSW-410H		
HDM-5063-16R-27	●	6	63	8										60	M12	0.7
HDM-6063-12R-27	●	6	6	60	27	20	12.4	7	22	M12	0.8	DSW-410H	A-15T			
HDM-6080-16R-27	●	6	80									8	55	76	M12	1.3
HDM-7080-12R-27	●	7	6	55	76	M12	1.4	DSW-410H	A-15T	RD**1204MO...						

Screw	Torque (N.m)
DSW-4512H	6
DSW-410H	3.6

MD	Hexagonal wrench(mm) for Arbor set bolt
M10	8
M12	10
M16	14
M20	17
M24	19

Inserts	Screw	Wrench
RD**1204MO*	DSW-410H	A-15T
RD**1606MO*	DSW-4512H	A-20

SUPER DIEMASTER

HDM/SDH Type



SDH
TYPE

Modular Type / Standard Pitch

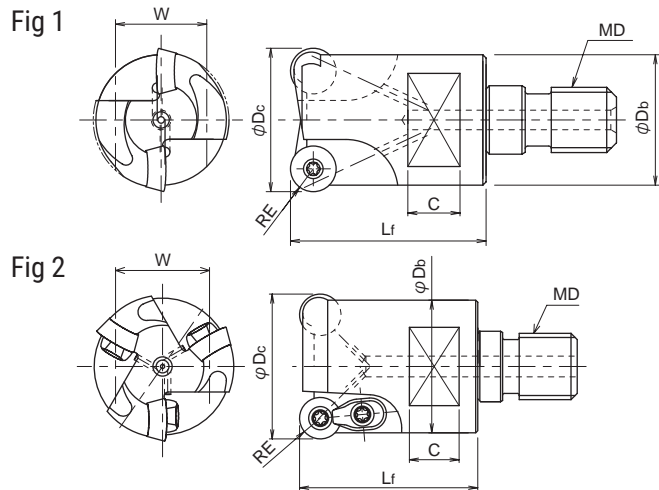
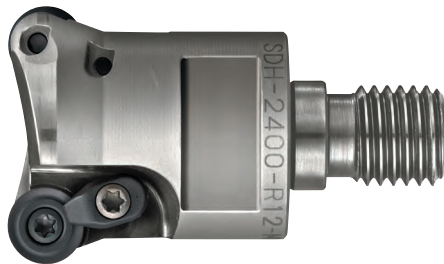

Cat.No.	Stock	No. of inserts	Dimensions(mm)							Parts			Inserts	Fig.					
			φDc	RE	Lf	φDb	MD	C	W	Screw	Clamp	Wrench							
SDH-2150-R07-M8	●	2	15	3.5	23	13.8	M8	8	12	TSW-2556H	-	A-08SD	RD**07T2MO...	1					
SDH-2160-R07-M8	●		16			M8													
SDH-2200-R07-M10	●		20		M10	30	10								17	CSW-408H	DCM-18	A-15	RD**1004MO...
SDH-2220-R07-M10	●		22																
SDH-2250-R10-M12	●	25	M12	35	12	22		DSW-410H	RD**1204MO...										
SDH-2280-R10-M12	●	28								M12									
SDH-2300-R10-M16	●	30	M16	43			13			26	DSW-410H	RD**1204MO...							
SDH-2320-R12-M16	●	32											M16						
SDH-3320-R10-M16	●	3	5		32	M16		CSW-408H	RD**1004MO...										
SDH-2350-R12-M16	●	2	6																
SDH-3350-R10-M16	●	3	5	32	M16	CSW-408H	RD**1004MO...												
SDH-2400-R12-M16	●	2	40					6	M16	13	26	DSW-410H	RD**1204MO...						

Screw	Torque (N.m)
TSW-2556H	1.1
CSW-408H	3.6
DSW-410H	3.6

SUPER DIEMASTER

HDM/SDH Type

SDH
TYPE

Modular Type / Fine Pitch

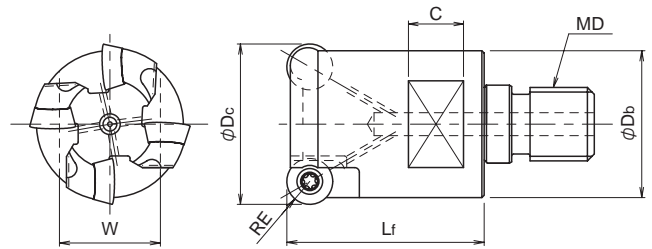

Cat.No.	Stock	No. of inserts	Dimensions(mm)							Parts		Inserts	
			φDc	RE	Lf	φDb	MD	C	W	Screw	Wrench		
SDH-3200-R07-M10	●	3	20	3.5	30	18	M10	8	14	TSW-2556H	A-08SD	RD**07T2MO...	
SDH-3220-R07-M10	●		22			20							
SDH-3250-R07-M12	●		25			23							
SDH-3250-R10-M12	●	4	28	35	25	M12	10	17	CSW-408H	A-15	RD**1004MO...		
SDH-3280-R10-M12	●											30	28
SDH-3300-R10-M16	●											32	28
SDH-4300-R10-M16	●	3	6	43	M16	12	22	DSW-410H	A-15	RD**1204MO...			
SDH-4320-R10-M16	●										35	5	
SDH-3350-R12-M16	●										40	6	
SDH-4350-R10-M16	●	4	5	32	M16	13	26	CSW-408H	A-15	RD**1004MO...			
SDH-4400-R12-M16	●										40	6	
SDH-5420-R10-M16	●										42	5	

Screw	Torque (N.m)
TSW-2556H	1.1
CSW-408H	3.6
DSW-410H	3.6

Insert

Standard type

Flat top inert

for General steel

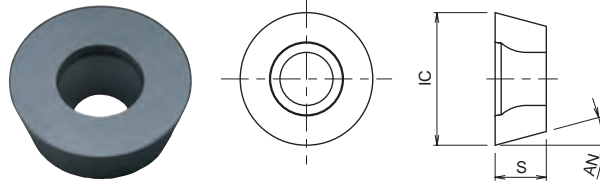

Cat.No.	Tolerance	PVD Coating			Dimensions(mm)		
		DH103	JC5040	JC8015	IC	S	AN
RDMW07T2MOT	M	●	●	●	7	2.7	15°
RDMW1004MOT		●	●	●	10	4.1	
RDMW1204MOT		●	●	●	12	4.8	
RDMW1606MOT		●	●	●	16	6	

Low cutting force

Chip breaker style

for Titanium + Inconel

for Stainless steel

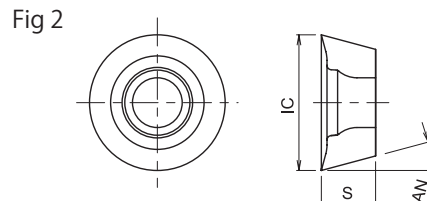
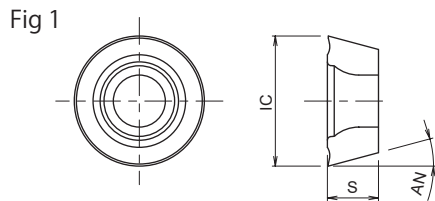

Cat.No.	Tolerance	PVD Coating			Dimensions(mm)			Fig.
		JC8015	JC8050	JC8118	IC	S	AN	
RDGT07T2MOE	G	●	●		7	2.7	15°	1
RDGT1004MOE		●	●		10	4.1		
RDGT1004MOT		●	●		12	4.8		
RDGT1204MOE		●	●		16	6		
RDGT1204MOT		●	●					
RDGT1606MOE		●	●					
RDGT1606MOT		●	●					
RDMT07T2MOE	M		●	●	7	2.7	15°	2
RDMT1004MOE			●	●	10	4.1		
RDMT1004MOE-ML			●	●	12	4.8		2
RDMT1004MOT			●	●				
RDMT1204MOE			●	●	16	6		1
RDMT1204MOE-ML			●	●				
RDMT1204MOT			●	●				
RDMT1606MOE			●	●				
RDMT1606MOT			●	●				

SUPER DIEMASTER

HDM/SDH Type

Insert

Low cutting force

Chip breaker style

for Aluminium

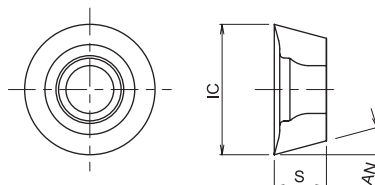

Cat.No.	Tolerance	Uncoated	Dimensions(mm)		
		FZ05	IC	S	AN
RDGT07T2MOF-AL	G	●	7	2.7	15°
RDGT1004MOF-AL		●	10	4.1	
RDGT1204MOF-AL		●	12	4.8	
RDGT1606MOF-AL		●	16	6	

SUPER DIEMASTER

HDM/SDH Type

Recommended Data for Profile Milling

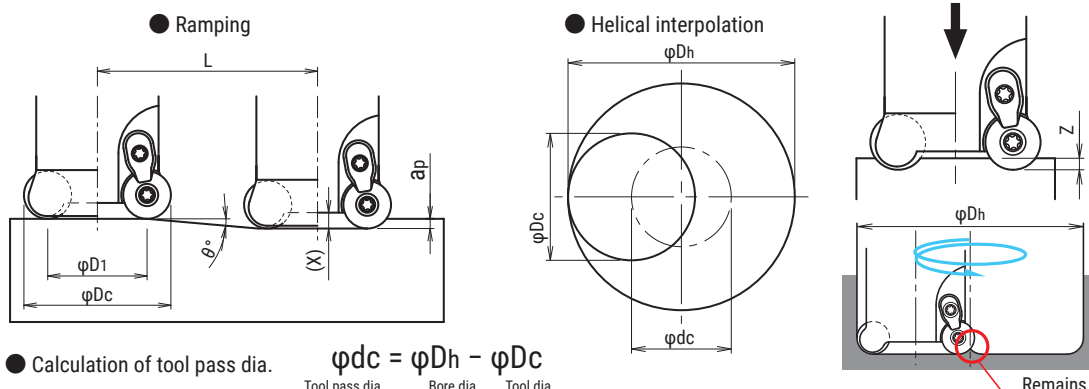

● Calculation of tool pass dia. $\varphi_{dc} = \varphi_{Dh} - \varphi_{Dc}$

Tool pass dia.
Bore dia.
Tool dia.

- Depth of cut per one circuit should not exceed max. depth of cut A_p .
- Down cutting is recommended, tool pass rotation should be counterclockwise
- Do not combine drilling and ramping together

- In case of ramping and helical interpolation, apply 70% or less feed (V_f) from standard cutting condition table.
- In case of drilling, apply 50% or less feed (V_f) from standard cutting condition table.
- Long chips may come out in case of drilling, confirm safe operating conditions.

Tool dia. (mm)	Insert dia. (R) (mm)	Effective cutting dia. φ_{D1} (mm)	Min. Bore dia. $D_{h \text{ min}}$ (mm)	Max. Bore dia. $D_{h \text{ max}}$ (mm)	Max. ramping angle: θ	Max. depth of cut: a_p (mm)	Max. depth of cut (a_p) Total cutting length: L (mm)	Max. drilling length: Z (mm)	Depth of holder face: X (mm)
15	7 (R3.5)	8	20	28	3°00'	3.5	66.8	0.4	1.0
16	7 (R3.5)	9	22	30	9°00'	3.5	22.1	1.5	2.5
20	7 (R3.5)	13	30	38	5°30'	3.5	36.3	1.5	2.5
22	7 (R3.5)	15	34	42	4°35'	3.5	43.6	1.5	2.5
25	7 (R3.5)	18	40	48	3°40'	3.5	54.6	1.5	2.5
25	10 (R5)	15	34	48	10°45'	5.0	26.3	2.5	3.5
28	10 (R5)	18	40	54	8°20'	5.0	34.1	2.5	3.5
30	10 (R5)	20	44	58	7°15'	5.0	39.3	2.5	3.5
32	10 (R5)	22	48	62	6°25'	5.0	44.4	2.5	3.5
32	12 (R6)	20	44	62	7°35'	6.0	45.1	2.5	3.5
35	10 (R5)	25	54	68	5°30'	5.0	51.9	2.5	3.5
35	12 (R6)	23	50	68	6°15'	6.0	54.7	2.5	3.5
40	12 (R6)	28	60	78	4°55'	6.0	69.7	2.5	3.5
42	10 (R5)	32	68	82	4°05'	5.0	70.0	2.5	3.5
50	12 (R6)	38	80	98	5°15'	6.0	65.2	3.5	4.5
50	16 (R8)	34	75	98	7°25'	8.0	61.4	4.0	5.0
52	12 (R6)	40	84	102	4°55'	6.0	69.7	3.5	4.5
52	16 (R8)	36	79	102	6°55'	8.0	65.9	4.0	5.0
63	12 (R6)	51	106	124	3°45'	6.0	91.5	3.5	4.5
63	16 (R8)	47	101	124	5°00'	8.0	91.4	4.0	5.0
66	12 (R6)	54	112	130	3°30'	6.0	98.1	3.5	4.5
66	16 (R8)	50	107	130	4°40'	8.0	98.0	4.0	5.0
80	12 (R6)	68	140	158	2°45'	6.0	124.9	3.5	4.5
80	16 (R8)	64	135	158	3°30'	8.0	130.7	4.0	5.0
100	16 (R8)	84	175	198	2°35'	8.0	177.3	4.0	5.0
125	16 (R8)	109	225	248	1°55'	8.0	239.1	4.0	5.0
160	16 (R8)	144	295	318	1°25'	8.0	223.5	4.0	5.0

SUPER DIEMASTER

HDM/SDH Type

■ Recommended Cutting Conditions

Material	Grade	Vc	Parameters	Insert Type			
				RD**07	RD**10	RD**12	RD**16
Carbon Steel below 250HB	JC8050	170 - 220	fz	~0.25	~0.30	~0.35	~0.37
	JC5040		ap	~1.5	~2.0	~2.5	~4.0
	JC8118		ae	0.7 Dc	0.7 Dc	0.7 Dc	0.7 Dc
Mold Steel 30-43HRC	JC8050	160 - 190	fz	~0.25	~0.29	~0.33	~0.34
	JC8118		ap	~1.5	~2.0	~2.5	~3.5
	JC8015		ae	0.6 Dc	0.6 Dc	0.6 Dc	0.6 Dc
Tool & Die Steel below 255HB	JC5040	160 - 190	fz	~0.25	~0.30	~0.35	~0.37
	JC8118		ap	~1.5	~2.0	~2.5	~4.0
			ae	0.7 Dc	0.7 Dc	0.7 Dc	0.7 Dc
Stainless Steel	JC8050	135 - 160	fz	~0.25	~0.26	~0.28	~0.32
	JC8015		ap	~1.5	~2.0	~2.5	~4.0
	JC8118		ae	0.6 Dc	0.6 Dc	0.6 Dc	0.6 Dc
Hardened Die Steel 40-50HRC	JC8015	120 - 140	fz	~0.20	~0.25	~0.25	~0.25
	DH103		ap	~0.8	~1.5	~1.5	~2.0
			ae	0.4 Dc	0.4 Dc	0.4 Dc	0.4 Dc
Grey & Nodular Cast Iron	JC8015	170 - 220	fz	~0.25	~0.30	~0.35	~0.40
	JC8118		ap	~1.5	~2.0	~2.5	~4.0
			ae	0.7 Dc	0.7 Dc	0.7 Dc	0.7 Dc
Titanium Alloy	JC8050	65	fz	~0.25	~0.25	~0.25	~0.25
	JC8015		ap	~0.5	~0.5	~1.0	~1.5
	JC8118		ae	0.6 Dc	0.6 Dc	0.6 Dc	0.6 Dc
Heat Resistant Alloy	JC8015	30	fz	~0.2	~0.2	~0.2	~0.25
	JC8118		ap	~0.5	~0.5	~1.0	~1.5
	JC8050		ae	0.6 Dc	0.6 Dc	0.6 Dc	0.6 Dc
Aluminium	FZ05	400 - 800	fz	~0.29	~0.30	~0.30	~0.39
			ap	~2.0	~3.5	~4.0	~5.5
			ae	0.6 Dc	0.6 Dc	0.6 Dc	0.6 Dc

Note

1. Please adjust cutting conditions according to machine rigidity or work rigidity.
2. In case of chatter occurring, recommended to reduce ap or Vf.
3. ap should be reduced when using on low rigidity machine.
4. Use airblow. (For cutting Aluminium, Titanium & Heat resistant alloy Wet cutting is recommended.)
5. When cutting Hard materials (50-55HRC), reduce ap, n & Vf by 30% from standard conditions.

SUPER DIEMASTER **HDM/SDH Type**

■ **Insert grades**

ISO	P					M					K				N				S				H		
	P01	P10	P20	P30	P40	M01	M10	M20	M30	M40	K01	K10	K20	K30	N01	N10	N20	N30	S01	S10	S20	S30	H01	H10	H20
Range	JC5040					JC8118					JC8015				FZ05				JC8118				JC8118		
	JC8118					JC8015					JC8015				FZ05				JC8118				DH103		
	JC8015					JC8050					JC8015				FZ05				JC8118				DH103		
	JC8015					JC8050					JC8015				FZ05				JC8118				DH103		

■ **Grade selection guide**

Material	Cast iron	Carbon steel · Tool steel				Mold steel		Hardened steel	Titanium alloy Inconel		Stainless steel		Aluminium
		Grade	JC8015 JC5118	JC5040	JC8118	JC8050	JC8015 JC8118		JC8050	DH103 (over 50HRC) JC8015 JC8118	JC8015 JC8118	JC8050	
RDMW07T2MOT	◎	◎	○			◎		◎	○		○		
RD * T07T2MOE	☆		☆	●		☆	●		◎	●	◎	●	
RDMW1004MOT	◎	◎	○			◎		◎					
RD * T1004MOT	☆					○					○	●	
RD * T1004MOE			☆	●		☆	●		○	●	☆		
RDMT1004MOE-ML										◎		◎	
RDMW1204MOT	◎	◎	○			◎		◎					
RD * T1204MOT	☆					○					○	●	
RD * T1204MOE			☆	●		☆	●		○	●	☆		
RDMT1204MOE-ML										◎		◎	
RDMW1606MOT	◎	◎	○			◎		◎					
RD * T1606MOT	☆					○					○	●	
RD * T1606MOE			☆	●		☆	●		○	◎	☆	◎	
RDGT****MOF-AL													◎

■ **Grade selection guide**

Material	Cast iron	Carbon steel Tool steel	Mold steel	Hardened steel	Stainless steel	Aluminium
Cat.No./Grade	DH103	JC8015	JC8015	DH103	JC8015	FZ05
RDMW****MOT	◎	◎	◎	◎	◎	
RDGT****MOF-AL						◎

• RDMW type : without chip breaker • RD*T type : with chip breaker
 ◎ : First choice ○ : General cutting ● : Unstable cutting ☆ : Light cutting

HEPTA MILL

HEP Type



HEP
TYPE

High Feed Mill with 7 Cutting-Edge

- Max. Depth of cut 5mm at fz=1mm/tooth is possible.
- Insert with thickness 6.35mm is durable for heavy roughing.
- Heptagonal insert with unique geometry for lower cutting force.
- Multi functional cutter for ramping , pocket milling , plunging.



Fig 1

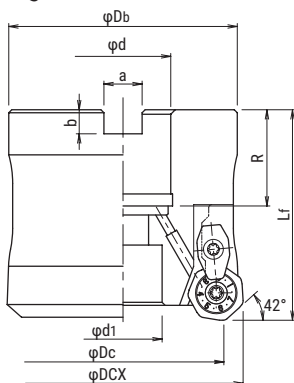

Fig 2

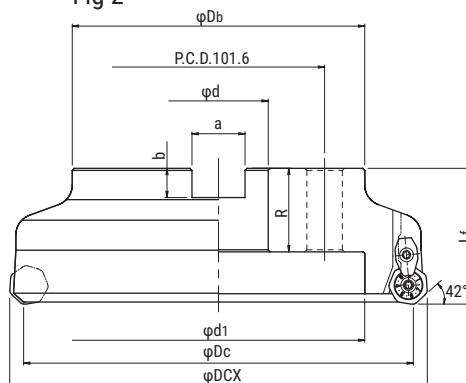
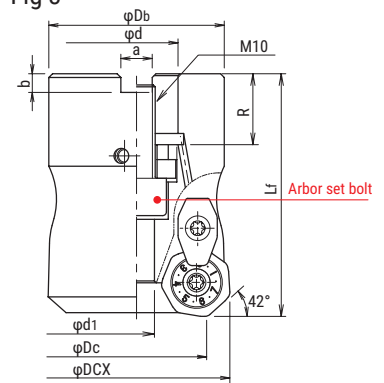

Fig 3



Cat.No.	Stock	No. of inserts	Dimensions (mm)									Arbor set bolt	Parts		Weight (kg)	Inserts	Fig.	
			φDc	φDCX	Lf	φDb	φd	φd1	a	b	ℓ		Screw	Wrench				
HEP-3050R-08-22	●	3	36.7	50	65	47	22	9.6	10.4	6.3	19	M10X1.5X25*	DSW-4512H	A-20	0.9	XD**080...	3	
HEP-4063R-08-22	●	4	49.5	63	50	60		17				27			20			12.4
HEP-4063R-08-27	●						1.1											
HEP-5080R-08-27	●	5	66.6	80	55	76	70	26	14.4	8	32	M12X1.75X30*			A-20L		1.9	1
HEP-6100R-08-32	●	6	86.6	100	96	32						M12X1.75X40*					3.6	
HEP-7125R-08-40	●	7	111.6	125	100	40	32	16.4	9	35	M16X2X45*	A-20L			5.5		2	
HEP-8160R-08-40	●	8	146.6	160											M20X2.5X45*			8.4
HEP-9200R-08-60	●	9	186.6	200	65	140	60	140	25.4	14.3	40	M16			10.2			

Screw	Torque(N.m)
DSW-4512H	6

Insert

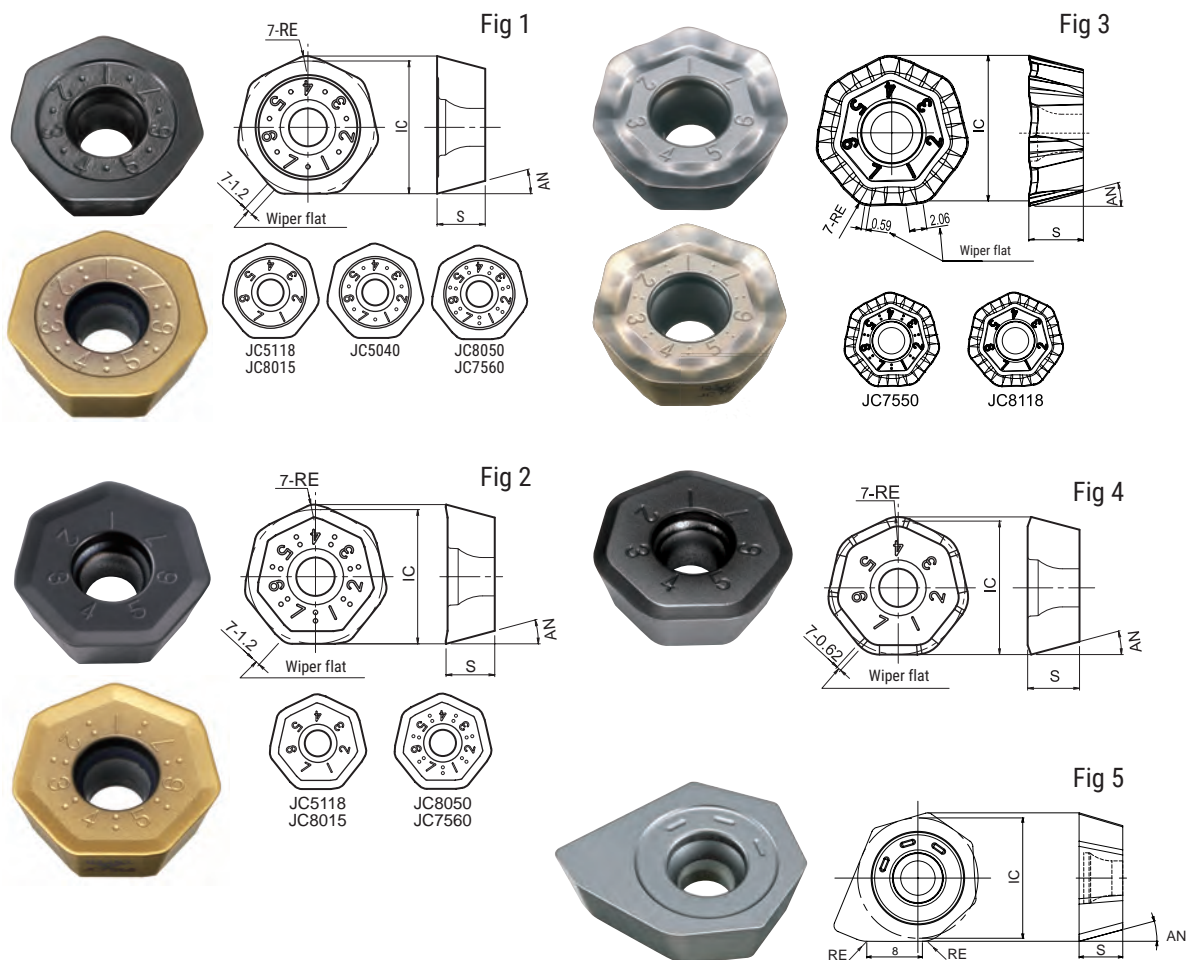

Cat.No.	Tolerance	PVD Coating						Dimensions(mm)				Fig.	
		JC5040	JC7550	JC7560	JC8011	JC8015	JC8050	JC8118	RE	IC	S		AN
XDMW080620ZTR	M	●		●		●	●	●	2	17.5	6.35	15°	1
XDMW080635ZTR-S						●			3.5				4
XDMT080620ZER				●		●	●	●	2		2		
XDMT080620ZER-ML			●					●		17.341	6.5		3
XDHW080610ZER-W		H				●				4	17.5		6.35

HEPTA MILL

HEP Type

■ Recommended Cutting Conditions

Material	Insert	Grade	General Cutting			Unstable Cutting			ae
			Vc	fz	ap	Vc	fz	ap	
Carbon Steel below 250HB	XDMT080620ZER (XDMW080620ZTR) [XDMW080620ZTR]	JC7560 (JC5040) [JC7560]	140	~0.8	~4	120	~0.8	~4	0.7 Dc
Tool & Die Steel below 255HB	XDMT080620ZER (XDMW080620ZTR) [XDMW080620ZTR]	JC7560 (JC5040) [JC7560]	140	~0.7	~3	120	~0.7	~3	0.7 Dc
Mold Steel 30-36 HRC	XDMT080620ZER (XDMT080620ZER) [XDMW080620ZTR]	JC8118 (JC7560) [JC5040]	140	~0.7	~3	120	~0.7	~3	0.7 Dc
Mold Steel 38-43 HRC	XDMT080620ZER (XDMT080620ZER) [XDMW080620ZTR]	JC8118 (JC8015) [JC8118]	100	~0.7	~3	90	~0.7	~3	0.7 Dc
Hardened Die Steel 42-52 HRC	XDMT080620ZER (XDMT080620ZER) [XDMW080620ZTR]	JC8118 (JC8015) [JC8118]	70	~0.4	~2	70	~0.3	~2	0.4 Dc
Grey Cast Iron	XDMT080620ZTR (XDMT080620ZTR) [XDMW080635ZTR-S]	JC8015 (JC8118) [JC8015]	140	~1.0	~5	120	~1.0	~5	0.7 Dc
Nodular Cast Iron	XDMT080620ZTR (XDMT080620ZTR) [XDMW080635ZTR-S]	JC8015 (JC8118) [JC8015]	120	~0.8	~4	100	~0.7	~4	0.7 Dc
Austenitic Stainless Steel	XDMT080620ZER (XDMT080620ZER) [XDMT080620ZER-ML]	JC8050 (JC7560) [JC7550]	120	~0.5	~4	100	~0.5	~4	0.7 Dc
Titanium Alloy	XDMT080620ZER-ML (XDMT080620ZER) [XDMT080620ZER]	JC7550 JC5040 [JC8118]	60	~0.3	~3	50	~0.2	~3	0.6 Dc
Heat Resistant Alloy	XDMT080620ZER-ML (XDMT080620ZER) [XDMT080620ZER]	JC8118 (JC8118) [JC8015]	30	~0.2	~2	25	~0.2	~2	0.5 Dc

Note

1. Please adjust cutting conditions according to machine rigidity or work rigidity.
2. In case of chatter occurring, recommended to reduce ap or Vf.
3. Use airblow.
4. XDMW080635ZTR-S is recommended to cut cast steel with crusty and nonuniform surface.

AERO CHIPPER

ALX/MAL/AMX/MAM Type



High Precision and High Efficient Machining on Aerospace tooling

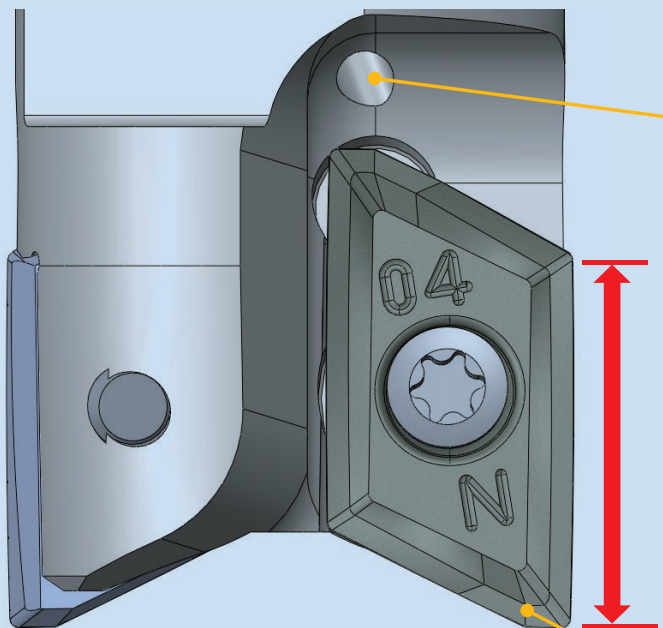

Through coolant hole

High Precision

Combination of high accuracy body and ground insert gives excellent side wall finish.

High Efficiency

Sharp & Unique 3D geometry insert enables high efficiency and low cutting resistance machining. Key in insert gives added security allowing high speed spindle machining.

Multi function

AERO CHIPPER

ALX/MAL/AMX/MAM Type



AMX/MAM
TYPE



- Bore type
φ40 - φ63
- Modular Head type
φ16 - φ42

MAX.ap = 8mm

XOET0803..PDFR
grade: FZ05

RE: 0.4 - 2.0



ALX/MAL
TYPE



- Bore type
φ50 - φ63
- Modular Head type
φ20 - φ40
- Shank type
φ20 - φ40

MAX.ap = 15mm

XOGT1605..PDFR
grade: FZ05

RE: 0.2 - 4.0



XOGT1605..PDER
grade: JC5118

RE: 0.2 - 3.2



AERO CHIPPER

AMX/MAM Type

AMX
TYPE

Bore Type

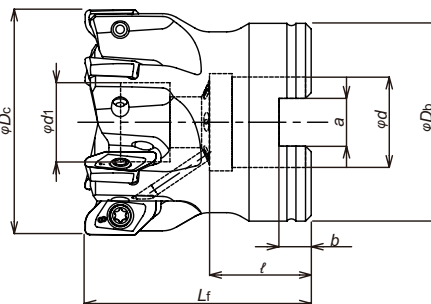
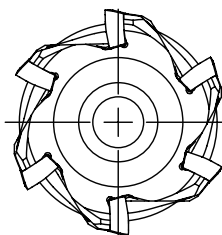
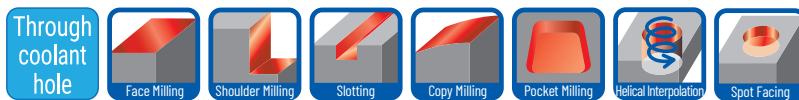

Cat.No.	Stock	No. of inserts	Dimensions(mm)								Max. spindle speed	Weight (kg)	Inserts
			φD_c	L_f	φD_b	φd	φd_1	a	b	ℓ			
AMX-6040R-16	●	6	40	40	35	16	14	8.4	5.6	18	28,000	0.2	XOET0803**PDFR
AMX-7050R-22	●	7	50	40	45	22	16.5	10.4	6.3	20	24,000	0.3	
AMX-8063R-22	●	8	63	40	50	22	17	10.4	6.3	20	21,000	0.48	

Screw	Torque(N.m)	Wrench
TSW-2567H	1.1	A-08

MAM
TYPE

Modular Type

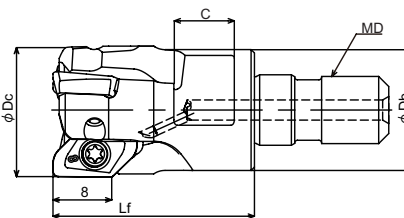
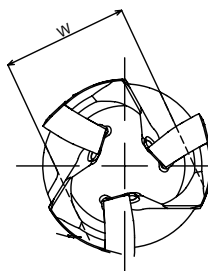

Cat.No.	Stock	No. of inserts	Dimensions(mm)						Max. spindle speed	Inserts	Parts	
			φD_c	L_f	φD_b	MD	C	W			Clamp screw	Wrench
MAM-2016-M8	●	2	16	23	14	M8	8	12	40,000	XOET0803**PDFR	TSW-2556H	A-08
MAM-3020-M10	●	3	20	30	18	M10	9	14	40,000			
MAM-3025-M12	○	3	25	35	22	M12	11	19	40,000			
MAM-4025-M12	●	4	25	35	22	M12	11	19	40,000			
MAM-4028-M12	○	4	28	35	23.6	M12	11	19	36,000			
MAM-4030-M16	○	4	30	43	27	M16	12	22	34,000			
MAM-5032-M16	●	5	32	43	29	M16	12	22	33,000			
MAM-5035-M16	○	5	35	43	32	M16	14	26	31,000			
MAM-6040-M16	●	6	40	43	32	M16	14	26	28,000			
MAM-6042-M16	○	6	42	43	32	M16	14	26	27,000			

Screw	Torque(N.m)	Wrench
TSW-2556H	1.1	A-08
TSW-2567H		

AERO CHIPPER

AMX/MAM Type

Insert

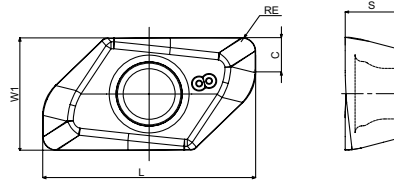

Cat.No.	Tolerance	Uncoated	Dimensions (mm)				
		FZ05	RE	L	W1	S	C
XOET080304PDFR	E	●	0.4	12.5	6.8	3.2	1.7
XOET080308PDFR		●	0.8	12.5	6.8	3.2	2
XOET080316PDFR		●	1.6	12.5	6.8	3.2	2.9
XOET080320PDFR		●	2.0	12.5	6.8	3.2	3

AERO CHIPPER

ALX/MAL Type

ALX
TYPE

Bore Type

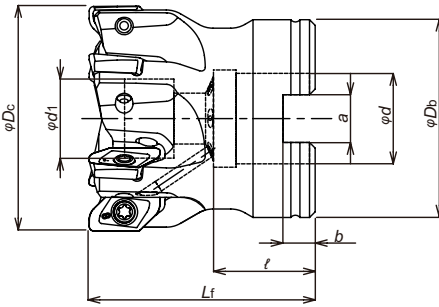
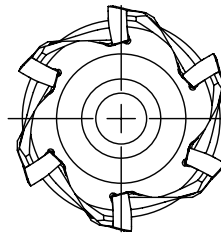

Cat.No.	Stock	No. of inserts	Dimensions(mm)								Max. spindle speed	Weight (kg)	Inserts
			φDc	Lf	φDb	φd	φd1	a	b	ℓ			
ALX4050R-22	●	4	50	50	45	22	16.5	10.4	6.3	20	24,000	0.4	XOGT1605**PD*R
ALX5063R-22	●	5	63		50						21,000	0.6	

Screw	Torque (N.m)	Wrench
DSW-4085	3.6	A-15T



MAL
TYPE

Modular Type

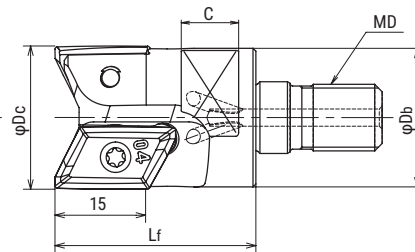
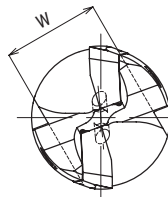

Cat.No.	Stock	No. of inserts	Dimensions(mm)						Max. spindle speed	Inserts
			φDc	Lf	φDb	MD	C	W		
MAL-1020-M10	●	1	20	35	19.5	M10	9	14	15,000	XOGT1605**PD*R
MAL-2025-M12	●	2	25		24	M12	10	19	40,000	
MAL-2028-M12	●		28	M16	12	22	26	36,000		
MAL-2030-M16	●	30	28					34,000		
MAL-2032-M16	●	32	29					33,000		
MAL-2035-M16	●	35	32					31,000		
MAL-3040-M16	●	3	40					32	28,000	

Screw	Torque (N.m)	Wrench
DSW-4085	3.6	A-15

Part to be modified

R2.6

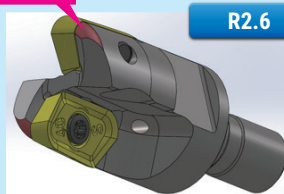

Part to be modified

C2.3

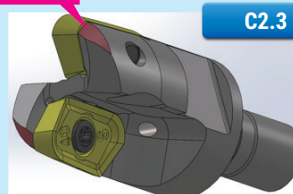

When using inserts with corner radius RE 4 (XOGT160540PDFR), Standard cutter body has to be modified with R2.6 or C2.3

AERO CHIPPER

ALX/MAL Type



ALXM
TYPE

Shank Type

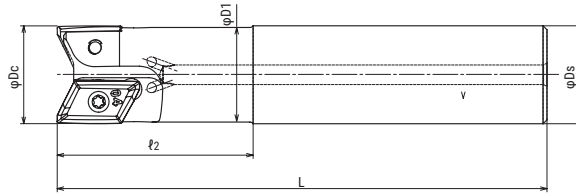

Cat.No.	Stock	No. of inserts	Dimensions(mm)					Max. spindle speed	Parts		Inserts
			φDc	l2	L	φD1	φDs		Screw	Wrench	
ALXM1020S20	●	1	20	35	110	19.18	20	15,000	DSW-4075H	A-15	XOGT1605**PD*R
ALXM2025S25	●	2	25	50	125	24	25	40,000	DSW-4085		
ALXM2028S25	●		28			26.87		36,000			
ALXM2032S32	●		32		30.5	33,000					
ALXM2035S32	●		35		33.32	31,000					
ALXM3040S32	●	3	40	80	170	37.96	32	28,000			

Screw	Torque (N.m)
DSW-4075H	3.6
DSW-4085	3.6

Insert

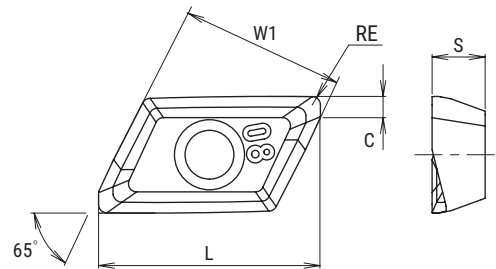

Cat.No.	Tolerance	PVD Coating	Uncoated	Dimensions (mm)					
		JC5118	FZ05	RE	L	W1	S	C	
XOGT160502PDFR	G		●	0.2	20.8	16.35	5	2.5	
XOGT160504PDFR			●	0.4	21.0			2.4	
XOGT160508PDFR			●	0.8				2.5	
XOGT160512PDFR			●	1.2	20.9			2.6	
XOGT160516PDFR			●	1.6	20.7			2.8	
XOGT160520PDFR			●	2.0	20.6			3.0	
XOGT160525PDFR			●	2.5	20.3			3.3	
XOGT160530PDFR			●	3.0	20.1			3.5	
XOGT160532PDFR			●	3.2	19.9			4.3	
XOGT160540PDFR			●	4.0	19.2			2.5	
XOGT160502PDER			●		0.2	20.8	16.35	5	2.5
XOGT160504PDER			●		0.4	21.0			2.4
XOGT160508PDER			●		0.8				2.5
XOGT160512PDER			●		1.2	20.9			2.6
XOGT160516PDER			●		1.6	20.7			2.8
XOGT160520PDER			●		2.0	20.6			3.0
XOGT160530PDER			●		3.0	20.1			3.3
XOGT160532PDER			●		3.2	19.9			4.3

AERO CHIPPER

AMX/MAM Type

Recommended Data for Profile Milling

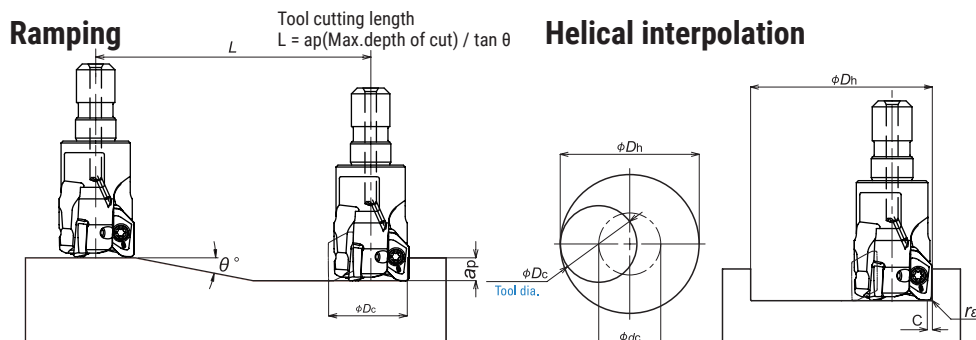

- Calculation of tool pass dia.

$$\phi_{dc} = \phi_{Dh} - \phi_{Dc}$$

Tool pass dia. Bore dia. Tool dia.

- Depth of cut per one circuit should not exceed max. depth of cut ap.
- Down cutting is recommended, so tool pass rotation should be counterclockwise.

Cat.No.	Tool dia.	RE	Eff. Cutting dia. (mm)	Max. Depth of cut (mm) ap	Ramping		Helical interpolation			Max. Drilling Depth (mm)
					Max. ramping angle θ°	Total cutting length at Max.ap L (mm)	Through hole Min. bore dia. Dh min (mm)	Flat bottom Min.bore dia. Df min (mm)	Through hole Max. bore dia. ϕDh max (mm)	
MAM-2016-M8	16	0.4	15.1	5	18	15.4	20	29.0	31	2.5
MAM-2016-M8	16	0.8	14.3	5	18	15.4	20	28.5	31	2.5
MAM-2016-M8	16	1.6	12.7	5	18	15.4	20	27.0	31	2.5
MAM-2016-M8	16	2.0	11.9	5	18	15.4	20	26.5	31	2.5
MAM-3020-M10	20	0.4	19.1	5	14	20.1	28	37.0	39	2.5
MAM-3020-M10	20	0.8	18.3	5	14	20.1	28	36.5	39	2.5
MAM-3020-M10	20	1.6	16.7	5	14	20.1	28	35.0	39	2.5
MAM-3020-M10	20	2.0	15.9	5	14	20.1	28	34.5	39	2.5
MAM-3025... / MAM-4025...	25	0.4	24.1	5	10	28.4	38	47.0	49	2.5
MAM-3025... / MAM-4025...	25	0.8	23.3	5	10	28.4	38	46.5	49	2.5
MAM-3025... / MAM-4025...	25	1.6	21.7	5	10	28.4	38	45.0	49	2.5
MAM-3025... / MAM-4025...	25	2.0	20.9	5	10	28.4	38	44.5	49	2.5
MAM-4028-M12	28	0.4	27.1	5	8.5	33.5	44	53.0	55	2.5
MAM-4028-M12	28	0.8	26.3	5	8.5	33.5	44	52.5	55	2.5
MAM-4028-M12	28	1.6	24.7	5	8.5	33.5	44	51.0	55	2.5
MAM-4028-M12	28	2.0	23.9	5	8.5	33.5	44	50.5	55	2.5
MAM-4030-M16	30	0.4	29.1	5	7.5	38.0	48	57.0	59	2.5
MAM-4030-M16	30	0.8	28.3	5	7.5	38.0	48	56.5	59	2.5
MAM-4030-M16	30	1.6	26.7	5	7.5	38.0	48	55.0	59	2.5
MAM-4030-M16	30	2.0	25.9	5	7.5	38.0	48	54.5	59	2.5
MAM-5032-M16	32	0.4	31.1	5	7	40.7	52	61.0	63	2.5
MAM-5032-M16	32	0.8	30.3	5	7	40.7	52	60.5	63	2.5
MAM-5032-M16	32	1.6	28.7	5	7	40.7	52	59.0	63	2.5
MAM-5032-M16	32	2.0	27.9	5	7	40.7	52	58.5	63	2.5
MAM-5035-M16	35	0.4	34.1	5	6	47.6	58	67.0	69	2.5
MAM-5035-M16	35	0.8	33.3	5	6	47.6	58	66.5	69	2.5
MAM-5035-M16	35	1.6	31.7	5	6	47.6	58	65.0	69	2.5
MAM-5035-M16	35	2.0	30.9	5	6	47.6	58	64.5	69	2.5
MAM-6040... / AMX-6040...	40	0.4	39.1	5	5	57.2	68	77.0	79	2.5
MAM-6040... / AMX-6040...	40	0.8	38.3	5	5	57.2	68	76.5	79	2.5
MAM-6040... / AMX-6040...	40	1.6	36.7	5	5	57.2	68	75.0	79	2.5
MAM-6040... / AMX-6040...	40	2.0	35.9	5	5	57.2	68	74.5	79	2.5
MAM-6042-M16	42	0.4	41.1	5	5	57.2	72	81.0	83	2.5
MAM-6042-M16	42	0.8	40.3	5	5	57.2	72	80.5	83	2.5
MAM-6042-M16	42	1.6	38.7	5	5	57.2	72	79.0	83	2.5
MAM-6042-M16	42	2.0	37.9	5	5	57.2	72	78.5	83	2.5
AMX-7050R-22	50	0.4	49.1	5	4	71.5	88	97.0	99	2.5
AMX-7050R-22	50	0.8	48.3	5	4	71.5	88	96.5	99	2.5
AMX-7050R-22	50	1.6	46.7	5	4	71.5	88	94.5	99	2.5
AMX-7050R-22	50	2.0	45.9	5	4	71.5	88	94.5	99	2.5
AMX-8063R-22	63	0.4	62.1	5	3	95.4	114	123.0	125	2.5
AMX-8063R-22	63	0.8	61.3	5	3	95.4	114	122.5	125	2.5
AMX-8063R-22	63	1.6	59.7	5	3	95.4	114	120.5	125	2.5
AMX-8063R-22	63	2.0	58.9	5	3	95.4	114	120.5	125	2.5

AERO CHIPPER

AMX/MAM Type

■ Recommended Cutting Conditions - Shoulder Milling -

● Bore Type

Material	Grade	Tool dia. (mm)														
		40					50					63				
		6N					7N					8N				
		ℓ	ap	ap×ae	n	Vf	ℓ	ap	ap×ae	n	Vf	ℓ	ap	ap×ae	n	Vf
Aluminium Alloy 50-110HB	FZ05	100	8	80	6000	5400	100	8	100	5700	5990	100	8	126	4500	5400
		150	6	42	6000	5400	150	8	80	5700	5990	150	8	126	4500	5400
		200	5	30	4800	4320	200	6	60	4600	4830	200	8	96	4500	5400

● Modular Type + MSN Type carbide shank holder

Material	Grade	Tool dia. (mm)														
		16					20					25				
		2N					2N					3N				
		ℓ	ap	ap×ae	n	Vf	ℓ	ap	ap×ae	n	Vf	ℓ	ap	ap×ae	n	Vf
Aluminium Alloy 50-110HB	FZ05	50	8	32	17900	5370	60	8	40	14300	6440	75	8	50	11500	5180
		80	6	15	17900	5370	100	6	18	14300	6440	125	6	24	11500	5180
		130	4	6	14300	4290	160	4	8	11500	5180	200	4	10	9200	4140

Material	Grade	Tool dia. (mm)									
		25/28					30				
		4N					4N				
		ℓ	ap	ap×ae	n	Vf	ℓ	ap	ap×ae	n	Vf
Aluminium Alloy 50-110HB	FZ05	75	8	50	11500	6900	90	8	60	9500	5700
		125	6	24	11500	6900	150	6	30	9500	5700
		200	4	10	9200	5520	240	4	12	7600	4560

Material	Grade	Tool dia. (mm)									
		32/35					40/42				
		5N					6N				
		ℓ	ap	ap×ae	n	Vf	ℓ	ap	ap×ae	n	Vf
Aluminium Alloy 50-110HB	FZ05	100	8	64	9000	6750	100	8	80	6000	5400
		160	6	30	9000	6750	160	6	36	6000	5400
		260	4	12	7200	5400	260	4	16	4800	4320

Note

1. The figure to be adjusted according to the machine rigidity or work rigidity.
2. In case of chatter occurring, recommended to reduce the depth of cut ap or Spindle speed
3. If machine does not have enough power, recommend to reduce the depth of cut ap or Spindle speed and Feed speed.
4. Use of water soluble cutting oil is recommended.

AERO CHIPPER

AMX/MAM Type

■ Recommended Cutting Conditions - Face Milling -

● Bore Type

Material	Grade	Tool dia. (mm)														
		40					50					63				
		6N					7N					8N				
		ℓ	ap	ae	n	Vf	ℓ	ap	ae	n	Vf	ℓ	ap	ae	n	Vf
Aluminium Alloy 50-110HB	FZ05	100	5	28	6000	5400	100	5	35	5700	5990	100	5	44	4500	5400
		150	2.5	28	6000	5400	150	3.5	35	5700	5990	150	5	44	4500	5400
		200	1.5	28	4800	4320	200	2.5	35	4600	4830	200	3	44	4500	5400

● Modular Type + MSN Type carbide shank holder

Material	Grade	Tool dia. (mm)														
		16					20					25				
		2N					2N					3N				
		ℓ	ap	ae	n	Vf	ℓ	ap	ae	n	Vf	ℓ	ap	ae	n	Vf
Aluminium Alloy 50-110HB	FZ05	50	5	11	17900	5370	60	5	14	14300	6440	75	5	17.5	11500	5180
		80	2.5	11	17900	5370	100	2.5	14	14300	6440	125	2.5	17.5	11500	5180
		130	1	11	14300	4290	160	1	14	11500	5180	200	1	17.5	9200	4140

Material	Grade	Tool dia. (mm)									
		25/28					30				
		4N					4N				
		ℓ	ap	ae	n	Vf	ℓ	ap	ae	n	Vf
Aluminium Alloy 50-110HB	FZ05	75	5	17.5	11500	6900	90	5	21	9500	5700
		125	2.5	17.5	11500	6900	150	2.5	21	9500	5700
		200	1	17.5	9200	5520	240	1	21	7600	4560

Material	Grade	Tool dia. (mm)									
		32/35					40/42				
		5N					6N				
		ℓ	ap	ae	n	Vf	ℓ	ap	ae	n	Vf
Aluminium Alloy 50-110HB	FZ05	100	5	22.5	9000	6750	100	5	28	6000	5400
		160	2.5	22.5	9000	6750	160	2.5	28	6000	5400
		260	1	22.5	7200	5400	260	1	28	4800	4320

Note

1. The figure to be adjusted according to the machine rigidity or work rigidity.
2. In case of chatter occurring, recommended to reduce the depth of cut ap or Spindle speed
3. If machine does not have enough power, recommend to reduce the depth of cut ap or Spindle speed and Feed speed.
4. Use of water soluble cutting oil is recommended.

AERO CHIPPER

ALX/MAL Type

Recommended Data for Profile Milling

Ramping

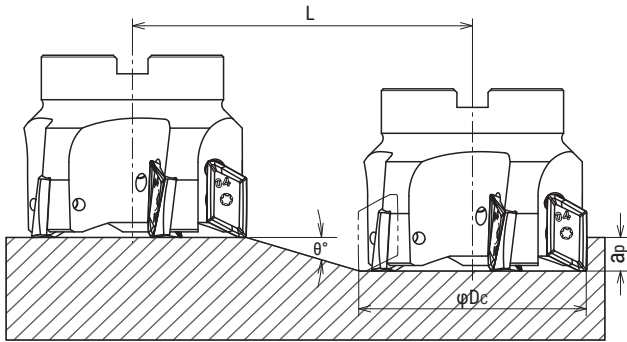

Tool dia. (mm)	Aluminium		Stainless steel		Titanium alloy		Max. Depth of cut (mm)
	Max. ramping angle (°)	Cutting length (mm)	Max. ramping angle (°)	Cutting length (mm)	Max. ramping angle (°)	Cutting length (mm)	
ϕD_c	θ°	L	θ°	L	θ°	L	a_p
20	16	28	10	45	10	45	8
25	11	41	9	51	9	51	8
28	9	51	7	65	7	65	8
30	8	57	6	76	6	76	8
32	7	65	6	76	6	76	8
35	6	76	6	76	6	76	8
40	5	91	5	91	5	91	8
50	4	114	4	114	4	114	8
63	3	153	3	153	3	153	8

Note

1. In case of ramping, apply 70% or less feed (Vf) from standard cutting condition table.
2. When cutting Titanium/Stainless steel, apply 0.005mm or less (fz) from standard cutting condition table.
3. Wet cutting is recommended.

Helical interpolation

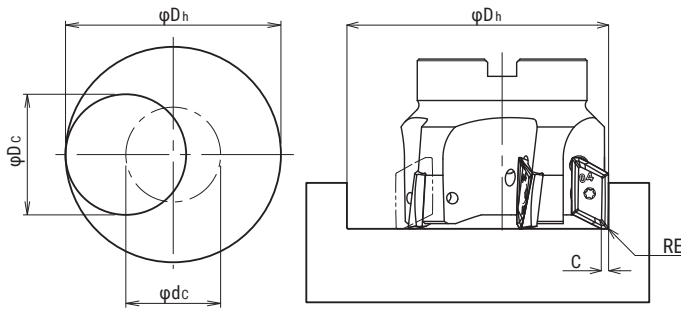

- Calculation of tool pass dia.

$$\phi_{dc} = \phi_{Dh} - \phi_{Dc}$$

Tool pass dia. Bore dia. Tool dia.

- Depth of cut per one circuit should not exceed max. depth of cut a_p

- Down cutting is recommended, tool pass rotation should be counterclockwise

Tool dia. (mm)	Min. bore dia. (mm)	Max. Bore dia. (mm)	Max. Depth of cut (mm)		
			Aluminium	Stainless steel	Titanium alloy
ϕD_c	ϕD_h min.	ϕD_h max.			
20	35.8	38.6	15	9	9
25	45.8	48.6	13	11	11
28	51.8	54.6	12	10	10
30	55.8	58.6	11	10	10
32	59.8	62.6	11	10	10
35	65.8	68.6	11	11	11
40	75.8	78.6	10	10	10
50	96.8	98.6	10	10	10
63	122.8	124.6	10	10	10

Note

1. In case of helical interpolation, apply 70% or less feed (Vf) from standard cutting condition table.
2. When cutting Titanium/Stainless steel, apply 0.005mm or less (fz) from standard cutting condition table.
3. Wet cutting is recommended.

Drilling

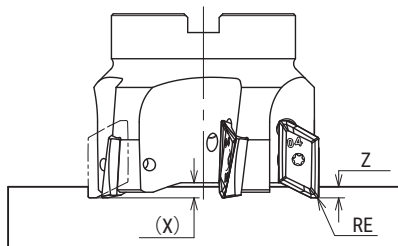

Coner radius R (mm)	Max. depth of cut: Z (mm)
RE	Z
R2.5 or below	3
R3 / R3.2	2
R4	1.5

Note

1. Do not combine drilling and ramping together.
2. In case of drilling, apply 50% or less feed (Vf) from standard cutting condition table.
3. Long chips may come out in case of drilling, confirm safe operating conditions.

AERO CHIPPER

ALX/MAL Type

■ Recommended Cutting Conditions - Shoulder Milling -

● Bore Type

Material	Grade	Tool dia. (mm)									
		50					63				
		4N					5N				
		ℓ	ap	ap×ae	n	Vf	ℓ	ap	ap×ae	n	Vf
Aluminium Alloy 50-110 HB	FZ05	100	15	150	5,700	4,560	100	15	225	4,500	4,500
		150	12	96	5,700	4,560	150	12	168	4,500	4,500
		200	9	54	5,700	4,560	200	9	108	4,500	4,500
Stainless Steel Below 250HB	JC5118	100	10	80	640	260	100	10	120	510	260
		150	8	48	640	260	150	8	88	510	260
		200	6	27	640	260	200	6	54	510	260
Titanium Alloy 35-43 HRC	JC5118	100	15	120	380	120	100	15	180	300	120
		150	12	72	380	120	150	12	132	300	120
		200	9	40	380	120	200	9	81	300	120

● Shank Type

Material	Grade	Tool dia. (mm)									
		20					25/28				
		2N					2N				
		ℓ	ap	ap×ae	n	Vf	ℓ	ap	ap×ae	n	Vf
Aluminium Alloy 50-110 HB	FZ05	35	12	40	14,300	1,430	50	15	75	11,500	4,600
		60	9	25	14,300	1,430	75	12	48	11,500	4,600
Stainless Steel Below 250HB	JC5118	35	2	12	1,590	160	50	10	40	1,270	250
		60	1.2	12	1,590	160	75	8	24	1,270	250
Titanium Alloy 35-43 HRC	JC5118	35	4	12	950	76	50	15	60	760	120
		60	2.5	12	950	76	75	12	36	760	120

Material	Grade	Tool dia. (mm)									
		32/35					40				
		2N					3N				
		ℓ	ap	ap×ae	n	Vf	ℓ	ap	ap×ae	n	Vf
Aluminium Alloy 50-110 HB	FZ05	50	15	120	9,000	3,600	80	15	125	7,200	4,320
		100	12	60	9,000	3,600	120	12	75	7,200	4,320
Stainless Steel Below 250HB	JC5118	50	10	60	990	200	80	10	65	800	240
		100	8	30	990	200	120	8	40	800	240
Titanium Alloy 35-43 HRC	JC5118	50	15	96	600	96	80	15	100	480	120
		100	12	48	600	96	120	12	60	480	120

Note

1. The figure to be adjusted according to the machine rigidity or work rigidity.
2. In case of chatter occurring, recommended to reduce the depth of cut ap or Spindle speed
3. If machine does not have enough power, recommend to reduce the depth of cut ap or Spindle speed and Feed speed.
4. Use of water soluble cutting oil is recommended when machining Aluminium alloy or Titanium alloy.

AERO CHIPPER

ALX/MAL Type

■ Recommended Cutting Conditions - Shoulder Milling -

● Modular Type + MSN Type carbide shank holder

Material	Grade	Tool dia. (mm)									
		20					25/28				
		1N					2N				
		ℓ	ap	ap×ae	n	Vf	ℓ	ap	ap×ae	n	Vf
Aluminium Alloy 50-110 HB	FZ05	60	12	40	14,300	1,430	75	15	75	11,500	4,600
		100	9	18	14,300	1,430	125	12	36	11,500	4,600
		160	5	8	11,500	1,150	200	6	15	9,200	3,680
Stainless Steel Below 250HB	JC5118	60	8	20	1,590	160	75	10	40	1,270	250
		100	6	10	1,590	160	125	8	20	1,270	250
		160	3	4	1,270	130	200	4	8	1,020	200
Titanium Alloy 35-43 HRC	JC5118	60	12	32	950	76	75	15	60	760	120
		100	9	15	950	76	125	12	30	760	120
		160	5	6	760	61	200	6	12	610	98

Material	Grade	Tool dia. (mm)									
		30/32/35					40				
		2N					3N				
		ℓ	ap	ap×ae	n	Vf	ℓ	ap	ap×ae	n	Vf
Aluminium Alloy 50-110 HB	FZ05	100	15	96	9,000	3,600	100	15	120	6,000	3,600
		160	12	48	9,000	3,600	160	12	60	6,000	3,600
		260	6	18	7,200	2,880	260	6	24	4,800	2,880
Stainless Steel Below 250HB	JC5118	100	10	50	990	200	100	10	65	660	200
		160	8	24	990	200	160	8	32	660	200
		260	4	10	800	160	260	4	12	530	160
Titanium Alloy 35-43 HRC	JC5118	100	15	75	600	96	100	15	96	400	96
		160	12	36	600	96	160	12	45	400	96
		260	6	15	480	77	260	6	18	320	77

Note

1. The figure to be adjusted according to the machine rigidity or work rigidity.
2. In case of chatter occurring, recommended to reduce the depth of cut ap or Spindle speed
3. If machine does not have enough power, recommend to reduce the depth of cut ap or Spindle speed and Feed speed.
4. Use of water soluble cutting oil is recommended when machining Aluminium alloy or Titanium alloy.

AERO CHIPPER

ALX/MAL Type

■ Recommended Cutting Conditions - Face Milling -

● Bore Type

Material	Grade	Tool dia. (mm)									
		50					63				
		4N					5N				
		ℓ	ap	ae	n	Vf	ℓ	ap	ae	n	Vf
Aluminium Alloy 50-110 HB	FZ05	100	6	35	5,700	4,560	100	7	44	4,500	4,500
		150	4	35	5,700	4,560	150	5	44	4,500	4,500
		200	2	35	5,700	4,560	200	3	44	4,500	4,500
Stainless Steel Below 250HB	JC5118	100	3	30	640	260	100	4	38	510	260
		150	2	30	640	260	150	2.5	38	510	260
		200	1	30	640	260	200	1.5	38	510	260
Titanium Alloy 35-43 HRC	JC5118	100	6	30	380	120	100	7	38	300	120
		150	4	30	380	120	150	5	38	300	120
		200	2	30	380	120	200	3	38	300	120

● Shank Type

Material	Grade	Tool dia. (mm)									
		20					25/28				
		2N					2N				
		ℓ	ap	ae	n	Vf	ℓ	ap	ae	n	Vf
Aluminium Alloy 50-110 HB	FZ05	35	4	14	14,300	1,430	50	6	17.5	11,500	4,600
		60	2.5	14	14,300	1,430	75	4	17.5	11,500	4,600
Stainless Steel Below 250HB	JC5118	35	2	12	1,590	160	50	3	15	1,270	250
		60	1.2	12	1,590	160	75	2	15	1,270	250
Titanium Alloy 35-43 HRC	JC5118	35	4	12	950	76	50	6	15	760	120
		60	2.5	12	950	76	75	4	15	760	120

Material	Grade	Tool dia. (mm)									
		32/35					40				
		2N					3N				
		ℓ	ap	ae	n	Vf	ℓ	ap	ae	n	Vf
Aluminium Alloy 50-110 HB	FZ05	50	7	22.5	9,000	3,600	80	6	28	7,200	4,320
		100	4	22.5	9,000	3,600	120	4	28	7,200	4,320
Stainless Steel Below 250HB	JC5118	50	4	19	990	200	80	3	24	800	240
		100	2	19	990	200	120	2	24	800	240
Titanium Alloy 35-43 HRC	JC5118	50	7	19	600	96	80	6	24	480	120
		100	4	19	600	96	120	4	24	480	120

Note

1. The figure to be adjusted according to the machine rigidity or work rigidity.
2. In case of chatter occurring, recommended to reduce the depth of cut ap or Spindle speed
3. If machine does not have enough power, recommend to reduce the depth of cut ap or Spindle speed and Feed speed.
4. Use of water soluble cutting oil is recommended when machining Aluminium alloy or Titanium alloy.

AERO CHIPPER

ALX/MAL Type

■ Recommended Cutting Conditions - Face Milling -

● Modular Type + MSN Type carbide shank holder

Material	Grade	Tool dia. (mm)									
		20					25/28				
		1N					2N				
		ℓ	ap	ae	n	Vf	ℓ	ap	ae	n	Vf
Aluminium Alloy 50-110 HB	FZ05	60	4	14	14,300	1,430	75	6	17.5	11,500	4,600
		100	2	14	14,300	1,430	125	3	17.5	11,500	4,600
		160	0.8	14	11,500	1,150	200	1.2	17.5	9,200	3,680
Stainless Steel Below 250HB	JC5118	60	2	12	1,590	160	75	3	15	1,270	250
		100	1	12	1,590	160	125	1.5	15	1,270	250
		160	0.5	12	1,270	130	200	0.6	15	1,020	200
Titanium Alloy 35-43 HRC	JC5118	60	4	12	950	76	75	6	15	760	120
		100	2	12	950	76	125	3	15	760	120
		160	0.8	12	760	61	200	1.2	15	610	98

Material	Grade	Tool dia. (mm)									
		30/32/35					40				
		2N					3N				
		ℓ	ap	ae	n	Vf	ℓ	ap	ae	n	Vf
Aluminium Alloy 50-110 HB	FZ05	100	6	22.5	9,000	3,600	100	6	28	6,000	3,600
		160	3	22.5	9,000	3,600	160	3	28	6,000	3,600
		260	1.2	22.5	7,200	2,880	260	1.2	28	4,800	2,880
Stainless Steel Below 250HB	JC5118	100	3	19	990	200	100	3	24	660	200
		160	1.5	19	990	200	160	1.5	24	660	200
		260	0.6	19	800	160	260	0.6	24	530	160
Titanium Alloy 35-43 HRC	JC5118	100	6	19	600	96	100	6	24	400	96
		160	3	19	600	96	160	3	24	400	96
		260	1.2	19	480	77	260	1.2	24	320	77

Note

1. The figure to be adjusted according to the machine rigidity or work rigidity.
2. In case of chatter occurring, recommended to reduce the depth of cut ap or Spindle speed
3. If machine does not have enough power, recommend to reduce the depth of cut ap or Spindle speed and Feed speed.
4. Use of water soluble cutting oil is recommended when machining Aluminium alloy or Titanium alloy.

S-HEAD SMSA Type

SMSA
TYPE

Solid Carbide Modular Head
with highly repetitive ground screw



- Applicable for General steel, Stainless steel, Heat resistant alloys and Titanium alloys.
- High accuracy for finishing both side walls and bottom surfaces.
- Coolant through the center of head.
- Available in 6 or 8 flutes.

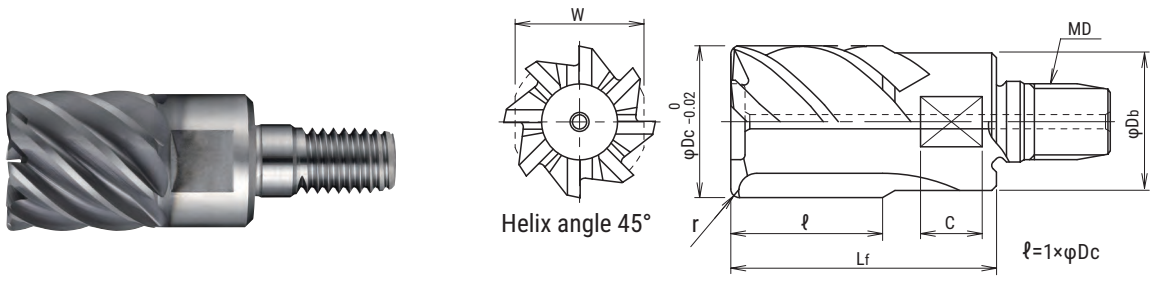

Cat.No.	Stock	No. of Flutes	Dimensions (mm)							
			φDc	r	ℓ	Lf	φDb	MD	C	W
SMSA-8160R05-M8	●	8	16	0.5	16	30	15	M8	5.5	14
SMSA-8160R10-M8	●			1						
SMSA-6160R20-M8	●			2						
SMSA-6160R30-M8	●	6	16	3	16	30	15	M8	5.5	14
SMSA-8200R05-M10	●			0.5						
SMSA-8200R10-M10	●			1						
SMSA-8200R20-M10	●	8	20	2	20	35	19	M10	5.5	17
SMSA-6200R30-M10	●			3						
SMSA-8250R10-M12	●			1						
SMSA-8250R20-M12	●	8	25	2	25	43	24	M12	5.5	22
SMSA-6250R30-M12	●			3						
SMSA-8300R10-M16	●			1						
SMSA-8300R20-M16	●	8	30	2	30	56	29	M16	5.5	27
SMSA-6300R30-M16	●			3						
SMSA-8320R10-M16	●			1						
SMSA-8320R20-M16	●	8	32	2	32	56	30	M16	5.5	27
SMSA-6320R30-M16	●			3						
SMSA-8320R30-M16	●			6						

PROPER MOUNTING OF S-HEAD

Use DIJET DS type spanner wrench to prevent over-tightening

Tightening torque

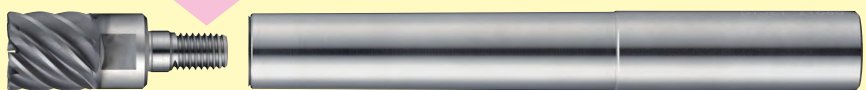

Tool dia. φDc (mm)	Width Across Flat W (mm)	Cat.No.	Tightening torque
φ16	14	DS-14	10~11N·m
φ20	17	DS-17	10~16N·m
φ25	22	DS-22	15~20N·m
φ30	27	DS-27	20~25N·m
φ32	27	DS-27	20~25N·m

S-HEAD

SMSA Type

■ Recommended cutting conditions

● Side cutting

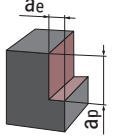
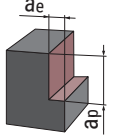
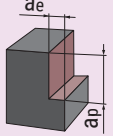
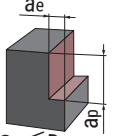
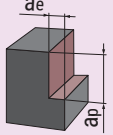
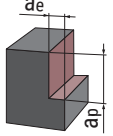
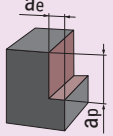
Material	Depth of cut 	Tool dia. (mm)					
		16			20		
		ℓ (mm)	n (min ⁻¹)	V_f (mm/min)	ℓ (mm)	n (min ⁻¹)	V_f (mm/min)
Carbon steel (S50C, S55C) below 250HB	 $a_p \leq D_c$ $a_e \leq 0.03D_c$	70	2,000	500	75	1,600	400
		110	1,800	400	125	1,400	300
		150	1,600	300	175	1,200	250
Mold steel (NAK80, HPM1, P21) 38-43HRC	 $a_p \leq D_c$ $a_e \leq 0.03D_c$	70	1,400	300	75	1,100	280
		110	1,200	240	125	950	200
		150	1,000	180	175	800	150
Austenitic stainless steel (SUS304, 316, 317)	 $a_p \leq D_c$ $a_e \leq 0.03D_c$	70	2,000	500	75	1,600	400
		110	1,800	400	125	1,400	300
		150	1,600	300	175	1,200	250
Aluminium alloy (A5052)	 $a_p \leq D_c$ $a_e \leq 0.03D_c$	70	4,000	900	75	3,200	800
		110	3,600	800	125	2,800	600
		150	3,200	700	175	2,500	500
Titanium alloy (Ti-6Al-4V) 35-43HRC	 $a_p \leq D_c$ $a_e \leq 0.03D_c$	70	1,400	300	75	1,100	280
		110	1,200	240	125	950	200
		150	1,000	180	175	800	150
Heat resistant alloy (INCO718) 35-43HRC	 $a_p \leq D_c$ $a_e \leq 0.03D_c$	70	800	200	75	600	150
		110	700	150	125	550	120
		150	600	120	175	500	100

Note

1. When finishing side wall, reduce a_e and increase a_p for higher efficiency and for preventing more heat generation.
2. When finishing bottom face, reduce a_p and increase V_f to optimize use of corner radius geometry for high feed machining.
3. Use appropriate coolant.

S-HEAD

SMSA Type

■ Recommended cutting conditions

● Side cutting

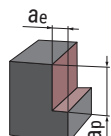
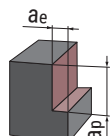
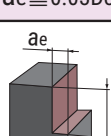
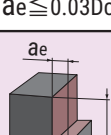
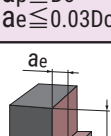
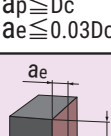
Material	Depth of cut 	Tool dia. (mm)					
		25			30/32		
		ℓ (mm)	n (min ⁻¹)	V_f (mm/min)	ℓ (mm)	n (min ⁻¹)	V_f (mm/min)
Carbon steel (S50C, S55C) below 250HB	 $a_p \leq D_c$ $a_e \leq 0.03D_c$	100	1,300	300	110	1,000	240
		150	1,150	250	160	900	200
		200	1,000	200	210	800	160
Mold steel (NAK80, HPM1, P21) 38-43HRC	 $a_p \leq D_c$ $a_e \leq 0.03D_c$	100	900	240	110	700	180
		150	800	180	160	600	130
		200	600	120	210	500	100
Austenitic stainless steel (SUS304, 316, 317)	 $a_p \leq D_c$ $a_e \leq 0.03D_c$	100	1,300	300	110	1,000	240
		150	1,150	250	160	900	200
		200	1,000	200	210	800	160
Aluminium alloy (A5052)	 $a_p \leq D_c$ $a_e \leq 0.03D_c$	100	2,600	650	110	2,000	500
		150	2,300	500	160	1,800	400
		200	2,000	400	210	1,600	300
Titanium alloy (Ti-6Al-4V) 35-43HRC	 $a_p \leq D_c$ $a_e \leq 0.03D_c$	100	900	240	110	700	180
		150	800	180	160	600	130
		200	600	120	210	500	100
Heat resistant alloy (INCO718) 35-43HRC	 $a_p \leq D_c$ $a_e \leq 0.03D_c$	100	500	120	110	400	100
		150	450	100	160	380	90
		200	400	80	210	350	80

Note

1. When finishing side wall, reduce a_e and increase a_p for higher efficiency and for preventing more heat generation.
2. When finishing bottom face, reduce a_p and increase V_f to optimize use of corner radius geometry for high feed machining.
3. Use appropriate coolant.

S-HEAD

SMSA Type

■ Recommended cutting conditions

● Bottom cutting

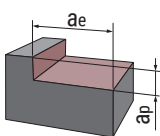
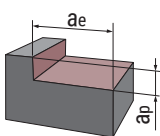
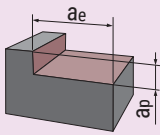
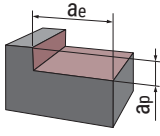
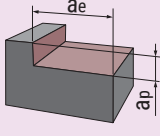
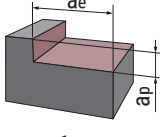
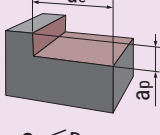
Material	Depth of cut 	Tool dia. (mm)					
		16			20		
		ℓ (mm)	n (min ⁻¹)	V_f (mm/min)	ℓ (mm)	n (min ⁻¹)	V_f (mm/min)
Carbon steel (S50C, S55C) below 250HB	 $a_e \leq D_c$ $a_p \leq 0.03D_c$	70	2,000	1,600	75	1,600	1,300
		110	1,800	1,400	125	1,400	1,100
		150	1,600	1,200	175	1,200	950
Mold steel (NAK80, HPM1, P21) 38-43HRC	 $a_e \leq D_c$ $a_p \leq 0.03D_c$	70	1,400	1,100	75	1,100	900
		110	1,200	950	125	950	800
		150	1,000	800	175	800	600
Austenitic stainless steel (SUS304, 316, 317)	 $a_e \leq D_c$ $a_p \leq 0.03D_c$	70	2,000	1,600	75	1,600	1,300
		110	1,800	1,400	125	1,400	1,100
		150	1,600	1,200	175	1,200	950
Aluminium alloy (A5052)	 $a_e \leq D_c$ $a_p \leq 0.03D_c$	70	4,000	3,200	75	3,200	2,500
		110	3,600	2,800	125	2,800	2,200
		150	3,200	2,500	175	2,500	2,000
Titanium alloy (Ti-6Al-4V) 35-43HRC	 $a_e \leq D_c$ $a_p \leq 0.03D_c$	70	1,400	1,100	75	1,100	900
		110	1,200	950	125	950	800
		150	1,000	800	175	800	600
Heat resistant alloy (INCO718) 35-43HRC	 $a_e \leq D_c$ $a_p \leq 0.03D_c$	70	800	650	75	600	500
		110	700	550	125	550	450
		150	600	500	175	500	400

Note

1. When finishing side wall, reduce a_e and increase a_p for higher efficiency and for preventing more heat generation.
2. When finishing bottom face, reduce a_p and increase V_f to optimize use of corner radius geometry for high feed machining.
3. Use appropriate coolant.

S-HEAD

SMSA Type

■ Recommended cutting conditions

● Bottom cutting

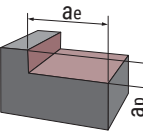
Material	Depth of cut 	Tool dia. (mm)					
		25			30/32		
		ℓ (mm)	n (min ⁻¹)	V_f (mm/min)	ℓ (mm)	n (min ⁻¹)	V_f (mm/min)
Carbon steel (S50C, S55C) below 250HB	$a_e \leq D_c$ $a_p \leq 0.03D_c$	100	1,300	1,000	110	1,000	800
		150	1,150	900	160	900	700
		200	1,000	800	210	800	600
Mold steel (NAK80, HPM1, P21) 38-43HRC	$a_e \leq D_c$ $a_p \leq 0.03D_c$	100	900	700	110	700	550
		150	800	600	160	600	500
		200	600	500	210	500	400
Austenitic stainless steel (SUS304, 316, 317)	$a_e \leq D_c$ $a_p \leq 0.03D_c$	100	1,300	1,000	110	1,000	800
		150	1,150	900	160	900	700
		200	1,000	800	210	800	600
Aluminium alloy (A5052)	$a_e \leq D_c$ $a_p \leq 0.03D_c$	100	2,600	2,000	110	2,000	1,600
		150	2,300	1,800	160	1,800	1,400
		200	2,000	1,600	210	1,600	1,200
Titanium alloy (Ti-6Al-4V) 35-43HRC	$a_e \leq D_c$ $a_p \leq 0.03D_c$	100	900	700	110	700	550
		150	800	600	160	600	500
		200	600	500	210	500	400
Heat resistant alloy (INCO718) 35-43HRC	$a_e \leq D_c$ $a_p \leq 0.03D_c$	100	500	400	110	400	320
		150	450	360	160	380	300
		200	400	320	210	360	280

Note

1. When finishing side wall, reduce a_e and increase a_p for higher efficiency and for preventing more heat generation.
2. When finishing bottom face, reduce a_p and increase V_f to optimize use of corner radius geometry for high feed machining.
3. Use appropriate coolant.

S-HEAD

SMAL Type

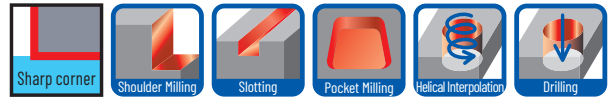

SMAL TYPE

S-HEAD for Aluminium

- Solid carbide modular head with multi-edges for aluminum.
- Positive geometry with 45 degree helix angle & 20 degree rake angle.
- 3 flutes allow excellent chip ejection.
- Through coolant holes prevent material welding.

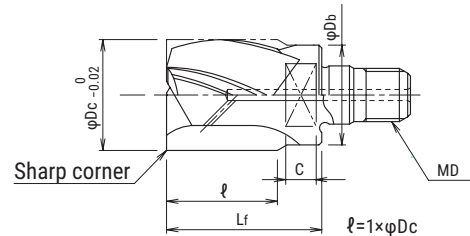
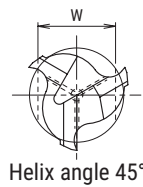
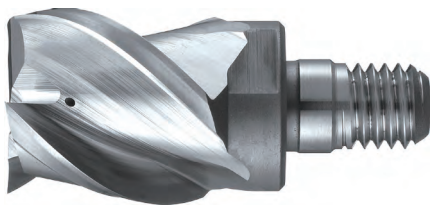
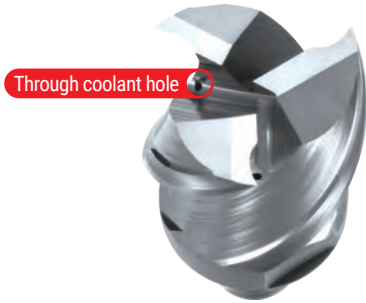

Cat.No.	Stock	No. of Flutes	Dimensions (mm)						
			φDc	ℓ	Lf	φDb	MD	C	W
SMAL-3180-M8	●	3	18	18	26	15	M8	5.5	14
SMAL-3200-M10	●		20	20	28	18	M10		
SMAL-3220-M10	●		22	22	31	19	M12		17
SMAL-3250-M12	●		25	25	35	23			19
SMAL-3280-M12	●		28	28	38	24	22		
SMAL-3320-M16	●		32	32	42	29	M16		27

PROPER MOUNTING OF S-HEAD

Use DIJET DS type spanner wrench to prevent over-tightening

Tightening torque



Tool dia φDc (mm)	Screw	Width Across Flat W (mm)	Cat. No.	Tightening torque
φ18	M8	14	DS-14	10~11N·m
φ20	M10	14	DS-14	10~16N·m
φ22	M10	17	DS-17	10~16N·m
φ25	M12	19	DS-19	15~20N·m
φ28	M12	22	DS-22	15~20N·m
φ32	M16	27	DS-27	20~25N·m

S-HEAD

SMAL Type

Recommended cutting conditions

Shoulder milling

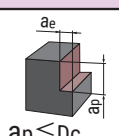
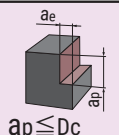
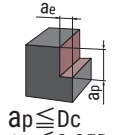
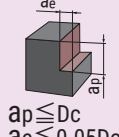
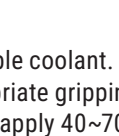
Material	Depth of cut 	Toll dia. (mm)											
		18		20		22		25		28		32	
		n (min ⁻¹)	Vf (mm/min)	n (min ⁻¹)	Vf (mm/min)	n (min ⁻¹)	Vf (mm/min)	n (min ⁻¹)	Vf (mm/min)	n (min ⁻¹)	Vf (mm/min)	n (min ⁻¹)	Vf (mm/min)
Aluminium alloy (A5052)	 $a_p \leq D_c$ $a_e \leq 0.05D_c$	3,200	800	2,800	700	2,600	650	2,300	570	2,050	510	1,800	450
Aluminium alloy (A7075)	 $a_p \leq D_c$ $a_e \leq 0.05D_c$	2,600	650	2,400	600	2,100	520	1,900	470	1,700	420	1,500	370
Aluminium alloy (Below Si 13%)	 $a_p \leq D_c$ $a_e \leq 0.05D_c$	3,200	800	2,800	700	2,600	650	2,300	570	2,050	510	1,800	450
Copper alloy (C1100)	 $a_p \leq D_c$ $a_e \leq 0.05D_c$	1,800	450	1,600	400	1,400	350	1,300	320	1,150	280	1,000	250

Note

1. Use water-soluble coolant.
2. Confirm appropriate gripping length of shank.
3. When ramping, apply 40~70% parameters from standard cutting conditions table.
4. Use rigid and accurate machine as possible.
5. If rpm available is lower than that recommended, reduce the feed rate proportionately.
6. Do not use higher rpm than that recommended.

Additional cutting conditions for longer tools

The percentages below should be applied, according to L/Dc.

1. Shoulder milling

L / Dc	n (min ⁻¹)	Vf (mm/min)	
~4Dc	0%	0%	-
5~6Dc	25% or below	30% or below	-
7~8Dc	40% or below	50% or below	Over Dc22 is not recommended

2. Slot milling

L / Dc	n (min ⁻¹)	Vf (mm/min)	a _p
~4Dc	0%	0%	0.15Dc or below
5~6Dc	not recommended		
7~8Dc	not recommended		

S-HEAD

SMSR Type

SMSR
TYPE

Anti-Vibration Solid Carbide Head



- Unequal pitch & irregular helix achieves stable machining.
- Positive geometry and through coolant hole prevent material welding and gives excellent chip evacuation.
- Widely applied from Carbon steel, Mold steel, Stainless steel & Ti-Alloy.

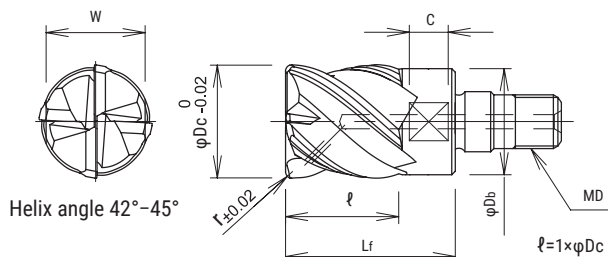

Cat.No.	Stock	No. of Flutes	Dimensions (mm)							
			φDc	r	ℓ	Lf	φDb	MD	C	W
SMSR-4160R05-M8	●	4	16	0.5	16	24	15	M8	5.5	14
SMSR-4160R10-M8	●			1						
SMSR-4160R20-M8	●			2						
SMSR-4160R30-M8	●			3						
SMSR-4200R05-M10	●		20	0.5	20	29	19	M10	17	
SMSR-4200R10-M10	●			1						
SMSR-4200R20-M10	●			2						
SMSR-4200R30-M10	●		3							
SMSR-4250R10-M12	●		25	1	25	35	24	M12	22	
SMSR-4250R20-M12	●			2						
SMSR-4250R30-M12	●			3						
SMSR-4300R10-M16	●		30	1	30	44	29	M16	27	
SMSR-4300R20-M16	●			2						
SMSR-4300R30-M16	●			3						
SMSR-4320R10-M16	●		32	1	32	46	30	M16	27	
SMSR-4320R20-M16	●			2						
SMSR-4320R30-M16	●	3								

PROPER MOUNTING OF S-HEAD

Use DIJET DS type spanner wrench to prevent over-tightening

Tightening torque

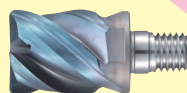



Tool dia φDc (mm)	Width Across Flat W (mm)	Cat. No.	Tightening torque
φ16	14	DS-14	10~11N·m
φ20	17	DS-17	10~16N·m
φ25	22	DS-22	15~20N·m
φ30	27	DS-27	20~25N·m
φ32	27	DS-27	20~25N·m

S-HEAD

SMSR Type

■ Recommended cutting conditions

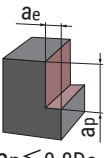
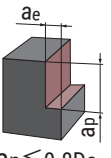
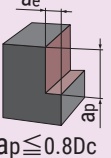
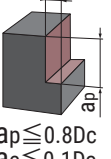
● Side cutting

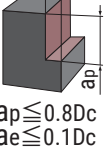
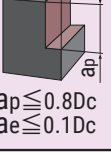
Material	Depth of cut 	Toll dia. (mm)								
		16			20			25		
		4N			4N			4N		
		ℓ (mm)	n (min ⁻¹)	V_f (mm/min)	ℓ (mm)	n (min ⁻¹)	V_f (mm/min)	ℓ (mm)	n (min ⁻¹)	V_f (mm/min)
Carbon steel (S50C, S55C) below 250HB	 $a_p \leq 0.8D_c$ $a_e \leq 0.1D_c$	70	2,980	1,430	70	2,390	1,150	100	1,910	920
		110	2,690	1,230	125	2,150	980	150	1,720	780
		150	2,390	1,030	175	1,910	830	200	1,530	660
Mold steel (NAK80, HPM1, P21) 38-43HRC	 $a_p \leq 0.8D_c$ $a_e \leq 0.1D_c$	70	2,390	1,150	70	1,910	920	100	1,530	730
		110	2,150	980	125	1,720	780	150	1,380	630
		150	1,910	830	175	1,530	660	200	1,220	530
Hardened die steel (SKD61, DAC, DHA) 42-52HRC	 $a_p \leq 0.8D_c$ $a_e \leq 0.1D_c$	70	1,390	670	70	1,110	530	100	890	430
		110	1,250	570	125	1,000	460	150	800	360
		150	1,110	480	175	890	380	200	710	310
Austenitic stainless steel (SUS304, 316, 317)	 $a_p \leq 0.8D_c$ $a_e \leq 0.1D_c$	70	1,990	960	70	1,590	760	100	1,270	610
		110	1,790	820	125	1,430	650	150	1,150	520
		150	1,590	690	175	1,270	550	200	1,020	440
Titanium alloy (Ti-6Al-4V) 35-43HRC	 $a_p \leq 0.8D_c$ $a_e \leq 0.1D_c$	70	1,590	640	70	1,270	510	100	1,020	410
		110	1,430	540	125	1,150	440	150	920	350
		150	1,270	460	175	1,020	370	200	810	290
Heat resistant alloy (INCO718) 35-43HRC	 $a_p \leq 0.8D_c$ $a_e \leq 0.1D_c$	70	990	200	70	800	160	100	640	130
		110	900	170	125	720	140	150	570	110
		150	800	140	175	640	120	200	510	90

■ Additional cutting conditions for longer tools

The percentages below should be applied, according to L/Dc.

L/D	n (min ⁻¹)	V_f (mm/min)	a_p (mm)	a_e (mm)
$L \leq 4D$	0%	0%	0%	0%
$4D < L \leq 6D$	20% reduction	30% reduction	0%	$\sim 0.05D_c$
$6D < L$	30% reduction	50% reduction	$\sim 0.5D_c$	$\sim 0.025D_c$

Note: Do not use for slot milling

S-HEAD

SMSR Type

■ Recommended cutting conditions

● Side cutting

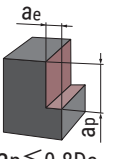
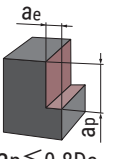
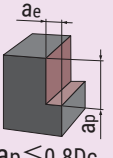
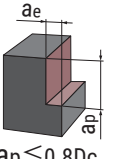
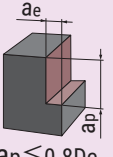
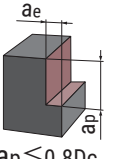
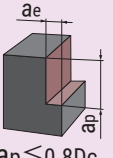
Material	Depth of cut 	Toll dia. (mm)								
		30			32					
		4N			4N					
		φ (mm)	n (min ⁻¹)	V_f (mm/min)	φ (mm)	n (min ⁻¹)	V_f (mm/min)			
Carbon steel (S50C, S55C) below 250HB	 $a_p \leq 0.8D_c$ $a_e \leq 0.1D_c$	110	1,590	760	110	1,490	720			
		160	1,430	650	160	1,340	610			
		210	1,270	550	210	1,190	510			
Mold steel (NAK80, HPM1, P21) 38-43HRC	 $a_p \leq 0.8D_c$ $a_e \leq 0.1D_c$	110	1,270	610	110	1,190	570			
		160	1,150	520	160	1,070	490			
		210	1,020	440	210	950	410			
Hardened die steel (SKD61, DAC, DHA) 42-52HRC	 $a_p \leq 0.8D_c$ $a_e \leq 0.1D_c$	110	740	360	110	700	340			
		160	670	310	160	630	290			
		210	590	250	210	560	240			
Austenitic stainless steel (SUS304, 316, 317)	 $a_p \leq 0.8D_c$ $a_e \leq 0.1D_c$	110	1,060	510	110	990	480			
		160	950	430	160	900	410			
		210	850	370	210	800	350			
Titanium alloy (Ti-6Al-4V) 35-43HRC	 $a_p \leq 0.8D_c$ $a_e \leq 0.1D_c$	110	850	340	110	800	320			
		160	760	290	160	720	270			
		210	680	240	210	640	230			
Heat resistant alloy (INCO718) 35-43HRC	 $a_p \leq 0.8D_c$ $a_e \leq 0.1D_c$	110	530	110	110	500	100			
		160	480	90	160	450	90			
		210	420	80	210	400	70			

S-HEAD SMHB Type



SMHB
TYPE

4 Flute Solid Carbide Ball Modular Head

For Hard or Difficult to Cut Materials from Roughing to Finishing

- Unique blade shape with sub pocket in center of cutting edge allows stable machining & good chip evacuation.
- Torsional angles of the ball & peripheral flutes are increased to reduce cutting resistance & suppress vibration.

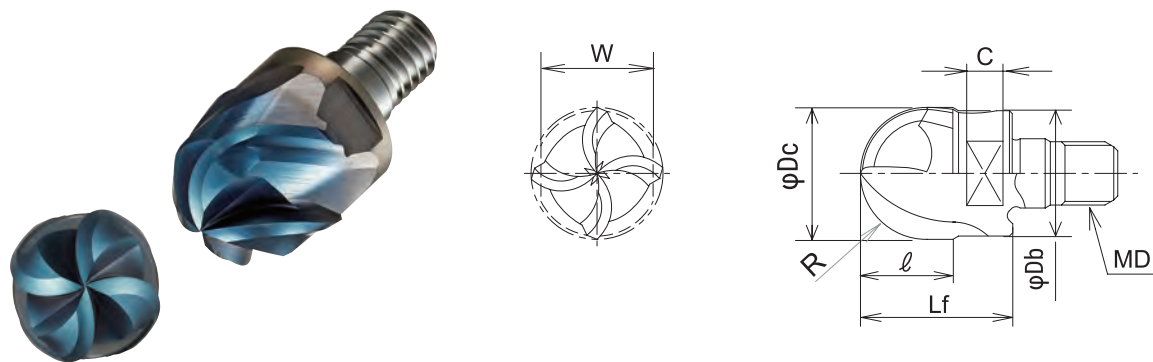

Cat.No.	Stock	No. of Flutes	Dimensions (mm)							
			φDc	R	ℓ	Lf	φDb	MD	C	W
SMHB-4160-M8	●	4	16	8	11.2	19	15	M8	5.5	14
SMHB-4200-M10	●		20	10	14	23	19	M10		17

◆ RECOMMENDED TIGHTENING TORQUE

Tool Dia. φDc(mm)	Tightening torque	Width Across Flat W (mm)	Cat.No.
φ16	10~11N·m	14	DS-14
φ20	10~16N·m	17	DS-17

← Use DIJET DS type spanner wrench to prevent over-tightening

Radius tolerance (mm)

Radius	R tolerance
R8	±0.008
R10	±0.010

■ Recommended cutting conditions

■ FINISHING

Material	Carbon steel · Alloy steel	Hardened die steel (SKD61, DAC, DHA) 42~52HRC	Stainless steel · Heat resistant alloy 38~42HRC				
Type of machining	 $ap \leq 0.03Dc$ $ae \leq 0.03Dc$	 $ap \leq 0.03Dc$ $ae \leq 0.03Dc$	 $ap \leq 0.03Dc$ $ae \leq 0.03Dc$				
Tool dia.	n	Vf	n	Vf	n	Vf	
R	φ Dc	(min ⁻¹)	(mm/min)	(min ⁻¹)	(mm/min)	(min ⁻¹)	(mm/min)
8	16	6,000	4,000	5,000	3,000	5,500	3,500
10	20	5,700	4,000	4,500	3,000	5,000	3,500

■ SEMI-FINISHING · ROUGHING

Material	Carbon steel · Alloy steel ~25HRC	Hardened die steel (SKD61, DAC, DHA) 42~52HRC	Stainless steel · Heat resistant alloy 38~42HRC				
Type of machining	 $ap \leq 0.1Dc$ $ae \leq 0.25Dc$	 $ap \leq 0.1Dc$ $ae \leq 0.25Dc$	 $ap \leq 0.1Dc$ $ae \leq 0.25Dc$				
Tool dia.	n	Vf	n	Vf	n	Vf	
R	φ Dc	(min ⁻¹)	(mm/min)	(min ⁻¹)	(mm/min)	(min ⁻¹)	(mm/min)
8	16	4,500	3,000	3,800	2,200	4,200	2,600
10	20	4,300	3,000	3,400	2,200	3,800	2,600

Carbide Modular Head Holder

MSN Type

Through coolant hole

MSN
TYPE

Solid Monoblock Carbide Body

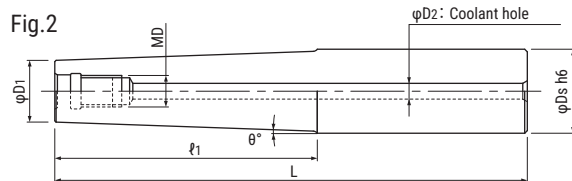
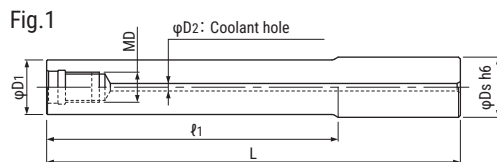

Cat.No.	Stock	Dimensions(mm)							Weight (kg)	Fig.
		φDs	ℓ1	L	φD1	θ°	MD	φD2		
MSN-M6-12-S10C	●	10	12	60	9.7	-	M6	3	0.06	1
MSN-M6-30-S10C	●	10	30	80	9.7	-			0.07	1
MSN-M6-50-S10C	●	10	50	100	9.7	-			0.09	1
MSN-M6-80-S10C	●	10	90	130	9.7	-			0.12	1
NEW MSN-M6-120-S10C	●	10	120	170	9.7	-			0.16	1
NEW MSN-M6-170-S10C	●	10	170	220	9.7	-			0.20	1
MSN-M6-35T-S12C	○	12	35	92	9.5	1°30'			0.12	2
MSN-M6-57T-S12C	●	12	57	114	9.5	1°			0.14	2
MSN-M6-15-S12C	●	12	15	60	11.5	-			0.08	1
MSN-M6-30-S12C	●	12	30	80	11.5	-			0.11	1
MSN-M6-50-S12C	●	12	50	100	11.5	-			0.13	1
MSN-M6-80-S12C	●	12	80	130	11.5	-			0.18	1
NEW MSN-M6-120-S12C	●	12	120	170	11.5	-			0.23	1
NEW MSN-M6-170-S12C	●	12	170	220	11.5	-			0.30	1
MSN-M6-65T-S16C	●	16	65	125	11.2	1°45'			0.28	2
MSN-M6-15-S16C	●	16	15	60	13.5	-			0.15	1
MSN-M6-30-S16C	●	16	30	80	13.5	-			0.19	1
MSN-M6-50-S16C	●	16	50	100	13.5	-			0.23	1
MSN-M6-80-S16C	●	16	80	130	13.5	-	0.28	1		
MSN-M8-20-S16C	●	16	20	75	15.5	-	M8	4	0.17	1
MSN-M8-40-S16C	●	16	40	95	15.5	-			0.22	1
MSN-M8-80-S16C	●	16	80	135	15.5	-			0.32	1
MSN-M8-120-S16C	●	16	120	175	15.5	-			0.42	1
MSN-M8-152-S16C	●	16	152	207	15.5	-			0.51	1
MSN-M8-40T-S20C	○	20	40	100	14.5	3°30'			0.36	2
MSN-M8-77T-S20C	●	20	77	143	14.5	1°45'			0.49	2
MSN-M10-20-S20C	●	20	20	80	19.5	-			M10	4
MSN-M10-40-S20C	●	20	40	100	19.5	-	0.39	1		
MSN-M10-70-S20C	●	20	70	130	19.5	-	0.50	1		
MSN-M10-90-S20C	●	20	90	150	19.5	-	0.60	1		
MSN-M10-140-S20C	●	20	140	200	19.5	-	0.80	1		
MSN-M10-160-S20C	●	20	160	220	19.5	-	0.87	1		
MSN-M10-210-S20C	●	20	210	270	19.5	-	1.07	1		
MSN-M10-40T-S20C	●	20	40	100	18.5	0°43'	0.39	2		
MSN-M10-90T-S20C	●	20	90	150	18.5	0°19'	0.58	2		
MSN-M10-140T-S20C	●	20	140	200	18.5	0°12'	0.77	2		
MSN-M10-85T-S25C	●	25	85	161	18.5	2°	0.90	2		

Carbide Modular Head Holder

MSN Type

MSN
TYPE

Solid Monoblock Carbide Body

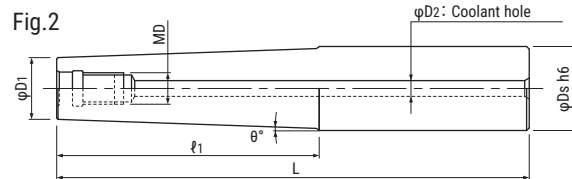
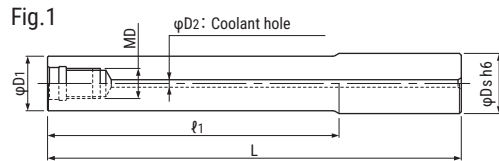
Through
coolant
hole

Cat.No.	Stock	Dimensions(mm)							Weight (kg)	Fig.
		φD_s	ℓ_1	L	φD_1	θ°	MD	φD_2		
MSN-M12-25-S25C	●	25	25	90	24	-	M12	6	0.53	1
MSN-M12-55-S25C	●	25	55	120	24	-			0.72	1
MSN-M12-70-S25C	●	25	70	135	24	-			0.81	1
MSN-M12-105-S25C	●	25	105	170	24	-			1.03	1
MSN-M12-135-S25C	●	25	135	215	24	-			1.30	1
MSN-M12-155-S25C	●	25	155	220	24	-			1.34	1
MSN-M12-200-S25C	●	25	200	265	24	1°30'			1.58	1
NEW MSN-M12-255-S25C	●	25	255	320	24	-			1.91	1
MSN-M12-100T-S32C	●	32	100	180	23.5	2°	1.61	2		
MSN-M16-25-S32C	●	32	25	90	29	-	M16	8	0.85	1
MSN-M16-55-S32C	●	32	55	120	29	-			1.13	1
MSN-M16-77-S32C	●	32	77	157	29	-			1.47	1
MSN-M16-97-S32C	●	32	97	177	29	-			1.64	1
MSN-M16-105-S32C	●	32	105	170	29	-			1.59	1
MSN-M16-127-S32C	●	32	127	207	29	-			1.89	1
MSN-M16-155-S32C	●	32	155	220	29	-			2.04	1
MSN-M16-177-S32C	●	32	177	257	29	-			2.32	1
MSN-M16-195-S32C	●	32	195	260	29	-			2.40	1
MSN-M16-225-S32C	●	32	225	290	29	-			2.57	1
MSN-M16-245-S32C	●	32	245	310	29	-			2.74	1
MSN-M16-295-S32C	●	32	295	360	29	-			3.17	1
NEW MSN-M16-315-S32C	●	32	315	380	29	-			3.34	1
MSN-M16-117T-S32C	●	32	117	197	29	0°38'			1.88	2
MSN-M16-127T-S32C	●	32	127	207	29	0°30'			2.23	2
MSN-M16-177T-S32C	●	32	177	257	29	0°23'			2.78	2
MSN-M16-197T-S32C	●	32	197	277	29	0°23'	3.00	2		

Carbide Modular Head Holder

MSN Type

Through
coolant
holeMSN-S
TYPE

Solid Monoblock Carbide Body

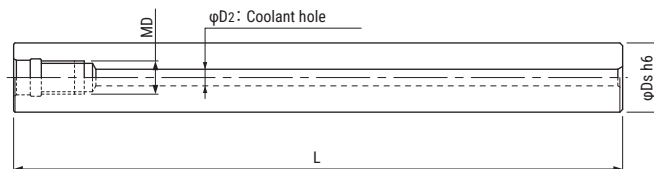

Cat.No.	Stock	Dimensions(mm)				Weight (kg)		
		φDs	L	MD	φD2			
MSN-M6-67S-S9.8C	●	9.8	67	M6	3	0.06		
MSN-M6-107S-S9.8C	●	9.8	107			0.10		
MSN-M6-82S-S10C	●	10	82			0.08		
MSN-M6-122S-S10C	●	10	122			0.12		
NEW MSN-M6-167S-S10C	●	10	167			0.16		
NEW MSN-M6-220S-S10C	●	10	220			0.21		
MSN-M6-80S-S11.8C	●	11.8	80			0.11		
MSN-M6-120S-S11.8C	●	11.8	120			0.17		
MSN-M6-90S-S12C	●	12	90			0.13		
MSN-M6-130S-S12C	●	12	130			0.19		
NEW MSN-M6-170S-S12C	●	12	170			0.25		
NEW MSN-M6-220S-S12C	●	12	220			0.32		
MSN-M8-87S-S14C	●	14	87			M8	4	0.16
MSN-M8-137S-S14C	●	14	137					0.26
MSN-M8-97S-S15C	●	15	97	0.21				
MSN-M8-147S-S15C	●	15	147	0.33				
MSN-M8-197S-S15C	●	15	197	0.44				
NEW MSN-M8-217S-S15C	●	15	217	0.49				
MSN-M8-107S-S16C	●	16	107	0.27				
MSN-M8-157S-S16C	●	16	157	0.40				
NEW MSN-M8-220S-S16C	●	16	220	0.57				

Carbide Modular Head Holder

MSN Type

Through
coolant
holeMSN-S
TYPE

Solid Monoblock Carbide Body

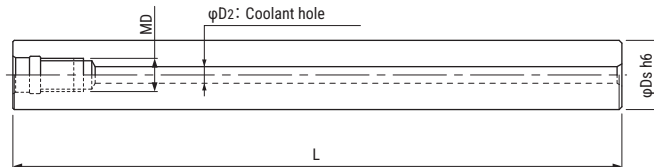

Cat.No.	Stock	Dimensions(mm)				Weight (kg)		
		φDs	L	MD	φD2			
MSN-M10-130S-S18C	●	18	130	M10	4	0.42		
MSN-M10-190S-S18C	●	18	190			0.62		
MSN-M10-240S-S18C	●	18	240			0.89		
NEW MSN-M10-270S-S18C	●	18	270			0.9		
MSN-M10-130S-S20C	●	20	130			0.53		
MSN-M10-190S-S20C	●	20	190			0.78		
MSN-M10-250S-S20C	●	20	250			1.02		
NEW MSN-M10-270S-S20C	●	20	270			1.13		
MSN-M12-185S-S23C	●	23	185			M12	6	0.98
MSN-M12-265S-S23C	●	23	265					1.42
MSN-M12-185S-S24C	●	24	185	1.07				
MSN-M12-265S-S24C	●	24	265	1.54				
MSN-M12-145S-S25C	●	25	145	0.91				
MSN-M12-215S-S25C	●	25	215	1.36				
MSN-M12-285S-S25C	●	25	285	1.80				
NEW MSN-M12-320S-S25C	●	25	320	2.06				
MSN-M16-160S-S28C	●	28	160	M16	8			1.22
MSN-M16-230S-S28C	●	28	230					1.77
MSN-M16-310S-S28C	●	28	310			2.41		
NEW MSN-M16-380S-S28C	●	28	380			2.97		
MSN-M16-157S-S32C	●	32	157			1.61		
MSN-M16-217S-S32C	●	32	217			2.22		
MSN-M16-287S-S32C	●	32	287			2.94		
MSN-M16-357S-S32C	●	32	357			3.66		
NEW MSN-M16-380S-S32C	●	32	380			3.98		

DRILLS



EZ HARD DRILL **EZH Type**

Feature 1

DH1 coating with high fracture toughness carbide substrate delivers stable drilling for high hardened materials up to 70HRC

Feature 2

Increased rigidity

Feature 3

Excellent breaking resistance

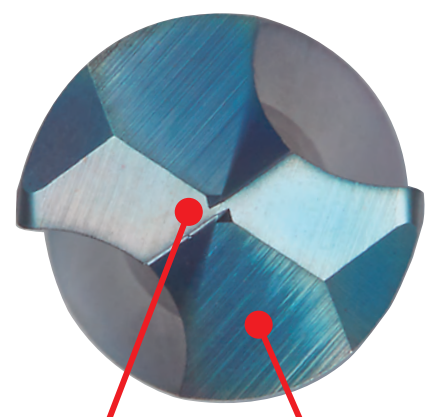

Optimized geometry specially for hardened materials

Larger web thickness

	DH1 coating	DV coating	DZ coating
Hardness (Hv)	3,500~3,700	3,300~3,500	2,800~2,900
Oxidization temperature (°C)	1,100~1,200	1,000~1,100	700~800
Coefficient of friction	0.5	0.65	0.6

EZ HARD DRILL

EZH/EZH-LS Type



EZH
TYPE

For Hard materials up to 70HRC

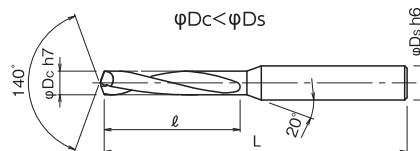
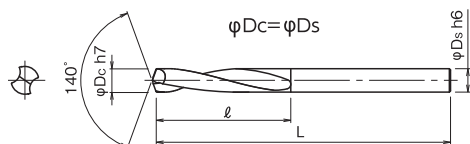

Cat.No	Stock	Dimension(mm)				
		φDc	ℓ	L	φDs	
EZH5D0200S03	●	2	16	55	3	
EZH5D0200S03-12	●		12			
EZH5D0200S03-21	●		21			
EZH5D0210S03	●	2.1	16			
EZH5D0220S03	●	2.2				
EZH5D0230S03	●	2.3				
EZH5D0240S03	●	2.4				
EZH5D0250S03	●	2.5				21
EZH5D0250S03-21	●					
EZH5D0260S03	●	2.6				16
EZH5D0270S03	●					
EZH5D0280S03	●					
EZH5D0290S03	●					
EZH5D0300S04	●					
EZH5D0330S04	●	3.3		24	59	4
EZH5D0340S04	●					
EZH5D0350S04	●	3.5	27			
EZH5D0380S04	●					
EZH5D0390S04	●					
EZH5D0400S04	●	4	29			
EZH5D0420S06	●					
EZH5D0430S06	●					
EZH5D0440S06	●					

Cat.No	Stock	Dimension(mm)				
		φDc	ℓ	L	φDs	
EZH5D0450S06	●	4.5	29	74	6	
EZH5D0490S06	●	4.9	32			
EZH5D0500S06	●	5				
EZH5D0510S06	●	5.1	34	79		
EZH5D0520S06	●	5.2				
EZH5D0590S06	●	5.9				
EZH5D0600S06	●	6	41			88
EZH5D0680S08	●	6.8	43			
EZH5D0690S08	●					
EZH5D0700S08	●	7	48	93		
EZH5D0790S08	●	7.9				
EZH5D0800S08	●	8				
EZH5D0850S10	●	8.5	53	98	10	
EZH5D0860S10	●	8.6	55			
EZH5D0900S10	●					
EZH5D0990S10	●	9.9	60	108		
EZH5D1000S10	●					
EZH5D1030S12	●	10.3	66	117		12
EZH5D1040S12	●	10.4				
EZH5D1100S12	●	11	68			
EZH5D1190S12	●	11.9				
EZH5D1200S12	●	12	73			

EZH-LS
TYPE

For Hard materials up to 70HRC



Cat.No	Stock	Dimension(mm)			
		φDc	ℓ	L	φDs
EZH5D0300S04-LS	●	3	25	69	4
EZH5D0330S04-LS	●	3.3			
EZH5D0380S04-LS	●	3.8	30	79	
EZH5D0400S04-LS	●	4			

Drill dia.	Tolerance
Dc ≤ 3	0 -0.01
3 < Dc ≤ 6	0 -0.012
6 < Dc ≤ 10	0 -0.015
10 < Dc	0 -0.018

■ Recommended Cutting Conditions

Material	Hardened Steel 48- 56 HRC	Hardened Steel 57 - 62 HRC	HSS 63 -70 HRC
Vc (m/min)	15 - 20 (Dc2) 15 - 20 (Dc2.5 - 12) 10 - 20 (Dc13 - 16)	10 - 15 (Dc2 - 12) 7 - 13 (Dc13 - 16)	5 - 10 (Dc2) 7 - 12 (Dc2.5 - 12) 6 - 10 (Dc13 - 16)
f (mm/rev)	0.03 - 0.05 (Dc 2 - 4) 0.04 - 0.06 (Dc 5) 0.06 - 0.08 (Dc 6 - 7) 0.06 - 0.09 (Dc 8 - 9) 0.06 - 0.10 (Dc 10 - 11) 0.07 - 0.12 (Dc 12 - 16)	0.03 - 0.05 (Dc 2 - 4) 0.04 - 0.06 (Dc 5) 0.05 - 0.07 (Dc 6 - 7) 0.05 - 0.08 (Dc 8 - 9) 0.05 - 0.09 (Dc 10 - 11) 0.05 - 0.10 (Dc 12 - 13) 0.07 - 0.12 (Dc 14 - 16)	0.02 - 0.04 (Dc 2 - 4) 0.03 - 0.05 (Dc 5) 0.04 - 0.06 (Dc 6 - 9) 0.04 - 0.07 (Dc 10 - 11) 0.05 - 0.08 (Dc 12 - 13) 0.06 - 0.09 (Dc 14 - 16)

Note

1. Use water-soluble coolant.
2. Not recommended for use on non-heat treated material.
3. Recommended for material over 50HRC to 70HRC.
4. Use on rigid machine with a precision holder.
5. Above data recommended for cutting depth of $3 \times D$. Peck-drilling is recommended if drilling deeper than $3 \times D$.
6. Recommended for drilling blind hole , if drilling thru, use back up material underneath.
7. When using -LS type, reduce above data.

FLAT DRILL **TLDM Type**

TLDM 2D TYPE For Spot facing

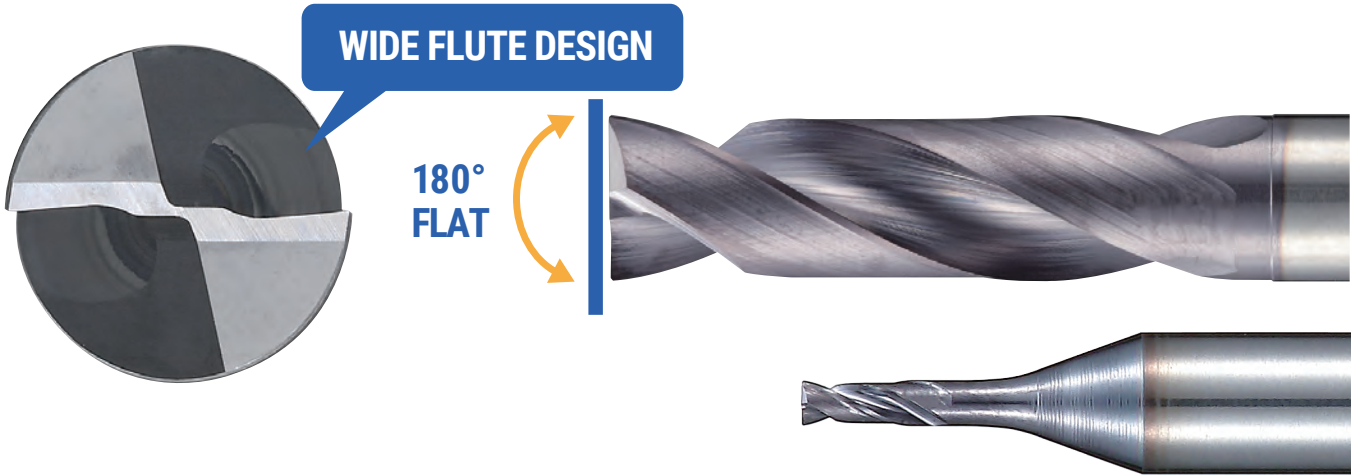

Applications

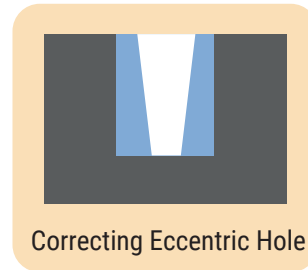
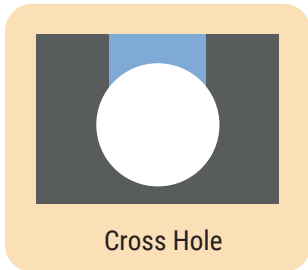
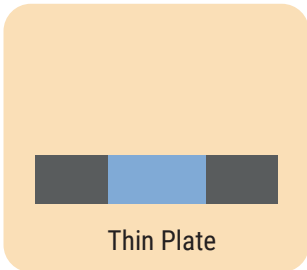
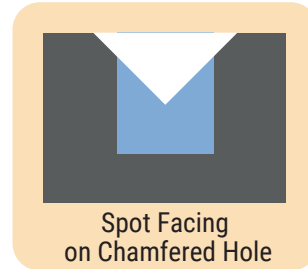
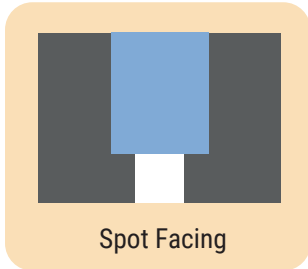
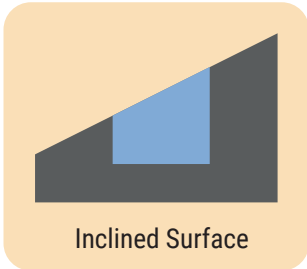

Material	Structual steel	Carbon steel	Alloy steel	Mold steel	Hardened steel (~50HRC)	Titanium alloy	Heat resistant alloy	Stainless steel	Cast iron	Aluminium alloy
		SS400	S50C	SCM440	NAK80	SKD61	Ti-6Al-4V	INCO718	SUS304	FC/FCD
	◎	◎	◎	◎	○	○	○	◎	◎	○

◎: Excellent ○: Good

FLAT DRILL

TLDM Type

TLDM 2D
TYPE

For Spot facing



Cat.No	Stock	Dimension(mm)															
		φDc	ℓ	L	φDs												
TLDM010	○	1.0	3.0	60	3												
TLDM011	○	1.1	3.3														
TLDM012	○	1.2	3.6														
TLDM013	○	1.3	3.9														
TLDM014	○	1.4	4.2														
TLDM015	○	1.5	4.5														
TLDM016	○	1.6	4.8														
TLDM017	○	1.7	5.1														
TLDM018	○	1.8	5.4														
TLDM019	○	1.9	5.7														
TLDM020	○	2.0	7.0	60	4												
TLDM021	○	2.1	7.5														
TLDM022	○	2.2	8.0														
TLDM023	○	2.3	8.5														
TLDM024	○	2.4	9.0														
TLDM025	○	2.5	9.5														
TLDM026	○	2.6	10.0														
TLDM027	○	2.7	10.5														
TLDM028	○	2.8	11.0														
TLDM029	○	2.9	11.5														
TLDM030	○	3.0	12	60	6												
TLDM030-S6	○																
TLDM031	○	3.1				13	60	4									
TLDM031-S6	○																
TLDM032	○	3.2							14	60	4						
TLDM032-S6	○																
TLDM033	○	3.3										15	60	4			
TLDM033-S6	○																
TLDM034	○	3.4													15	60	4
TLDM034-S6	○																
TLDM035	○	3.5	15	60	4												
TLDM035-S6	○																
TLDM036	○	3.6				15	60	4									
TLDM036-S6	○																
TLDM037	○	3.7							15	60	4						
TLDM037-S6	○																
TLDM038	○	3.8										15	60	4			
TLDM038-S6	○																

Cat.No	Stock	Dimension(mm)				
		φDc	ℓ	L	φDs	
TLDM039	○	3.9	15	60	4	
TLDM039-S6	○				6	
TLDM040	○				4	
TLDM040-S6	○	4.0	16	60	4	
TLDM041	○				4.1	
TLDM042	○				4.2	
TLDM043	○	4.3	17	60	6	
TLDM044	○					4.4
TLDM045	○					4.5
TLDM046	○	4.6	18	65	6	
TLDM047	○					4.7
TLDM048	○					4.8
TLDM049	○	4.9	19	65	6	
TLDM050	○					5.0
TLDM051	○					5.1
TLDM052	○	5.2	20	65	6	
TLDM053	○					5.3
TLDM054	○					5.4
TLDM055	○	5.5	21	65	6	
TLDM056	○					5.6
TLDM057	○					5.7
TLDM058	○	5.8	22	70	6	
TLDM059	○					5.9
TLDM060	○					6.0
TLDM061	○	6.1	23	70	6	
TLDM062	○					6.2
TLDM063	○					6.3
TLDM064	○	6.4	24	70	6	
TLDM065	○					6.5
TLDM066	○					6.6
TLDM067	○	6.7	25	75	8	
TLDM068	○					6.8
TLDM069	○					6.9
TLDM070	○	7.0	26	75	8	
TLDM071	○					7.1
TLDM072	○					7.2
TLDM073	○	7.3	27	75	8	
TLDM074	○					7.4

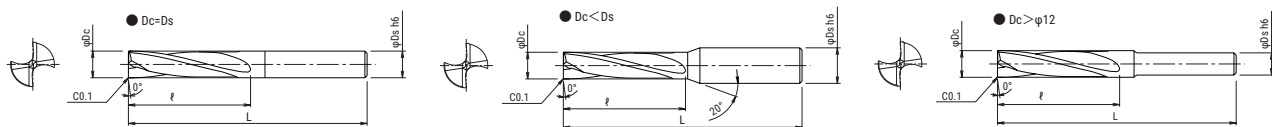

Cat.No	Stock	Dimension(mm)					
		φDc	ℓ	L	φDs		
TLDM075	○	7.5	29	75	8		
TLDM076	○	7.6					
TLDM077	○	7.7					
TLDM078	○	7.8					
TLDM079	○	7.9					
TLDM080	○	8.0					
TLDM081	○	8.1	31	80	10		
TLDM082	○	8.2					
TLDM083	○	8.3					
TLDM084	○	8.4					
TLDM085	○	8.5					
TLDM086	○	8.6					
TLDM087	○	8.7					
TLDM088	○	8.8					
TLDM089	○	8.9					
TLDM090	○	9.0	32			85	12
TLDM091	○	9.1					
TLDM092	○	9.2					
TLDM093	○	9.3					
TLDM094	○	9.4					
TLDM095	○	9.5					
TLDM096	○	9.6					
TLDM097	○	9.7					
TLDM098	○	9.8					
TLDM099	○	9.9					
TLDM100	○	10.0					
TLDM101	○	10.1					
TLDM102	○	10.2					
TLDM103	○	10.3					
TLDM104	○	10.4					
TLDM105	○	10.5					
TLDM106	○	10.6					
TLDM107	○	10.7					
TLDM108	○	10.8					
TLDM109	○	10.9					
TLDM110	○	11.0					

Cat.No	Stock	Dimension(mm)					
		φDc	ℓ	L	φDs		
TLDM111	○	11.1	43	85	12		
TLDM112	○	11.2					
TLDM113	○	11.3					
TLDM114	○	11.4					
TLDM115	○	11.5					
TLDM116	○	11.6					
TLDM117	○	11.7	45	90	12		
TLDM118	○	11.8					
TLDM119	○	11.9					
TLDM120	○	12.0					
TLDM125	○	12.5	48			95	100
TLDM130	○	13.0	50				
TLDM135	○	13.5	52				
TLDM140	○	14.0	54				

Drill dia.	Tolerance
$Dc \leq 3$	0
	-0.01
$3 < Dc \leq 6$	0
	-0.012
$6 < Dc \leq 10$	0
	-0.015
$10 < Dc$	0
	-0.018

FLAT DRILL

TLDM Type

■ Recommended Cutting Conditions

● TLDM (2D) type

Material	Structural Steel below 180HB	Carbon Steel below 280HB	Alloy Steel 280-350HB	Mold Steel 38-43HRC	Hardened Steel below 50HRC
Vc (m/min)	50 - 100	50 - 100	30 - 70	20 - 50	15 - 30
f (mm/rev)	0.01 - 0.05 (Dc1-2)	0.01 - 0.05 (Dc1-2)	0.01 - 0.04 (Dc1-2)	0.005 - 0.03 (Dc1-2)	0.005 - 0.03 (Dc1-2)
	0.06 - 0.24 (Dc3-14)	0.06 - 0.24 (Dc3-14)	0.06 - 0.24 (Dc3-14)	0.06 - 0.20 (Dc3-14)	0.03 - 0.12 (Dc3-14)

Material	Titanium Alloy	Heat Resistant Alloy	Stainless Steel	Grey & Nodular Cast Iron	Aluminium Alloy
Vc (m/min)	20 - 50	10 - 20	10 - 50	50 - 100	50 - 150
f (mm/rev)	0.005 - 0.03 (Dc1-2)	0.005 - 0.03 (Dc1-2)	0.005 - 0.03 (Dc1-2)	0.01 - 0.05 (Dc1-2)	0.01 - 0.08 (Dc1-2)
	0.06 - 0.20 (Dc3-14)	0.01 - 0.04 (Dc3-14)	0.06 - 0.20 (Dc3-14)	0.06 - 0.24 (Dc3-14)	0.06 - 0.24 (Dc3-14)

Note

1. These cutting conditions are for drilling flat surface. when drilling angled surfaces, parameters should be adjusted.
For inclined angle under 30°, apply 40-80% of (Vf) and for inclined angle 30° or more , apply 20-50% of (Vf) from standard cutting conditions.
2. Use water-soluble coolant.
3. Drilling over 2 x Dc is not recommended.
4. Side milling is not possible.
5. Use 0.5mm step feed for drilling Heat-resistant alloy.
6. In case of long chips , adjust parameters by increasing (Vf) or using step feed for breaking chips.



Feature 1

High hole accuracy

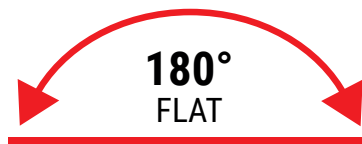

Feature 2

Capable of a wide range of applications such as spot facing on slope, correction of eccentric holes, and thin plate machining.



Feature 3

Double margin allows high precision straight drilling.

Feature 4

DV coating which has perfect balance between fracture & wear resistance and Smooth treatment on surface of drill ensure excellent tool life.

Feature 5

Applicable for a wide range of work materials; Carbon steel, Tool steel, Mould steel, Stainless steel, Cast iron and Aluminium.

Applications

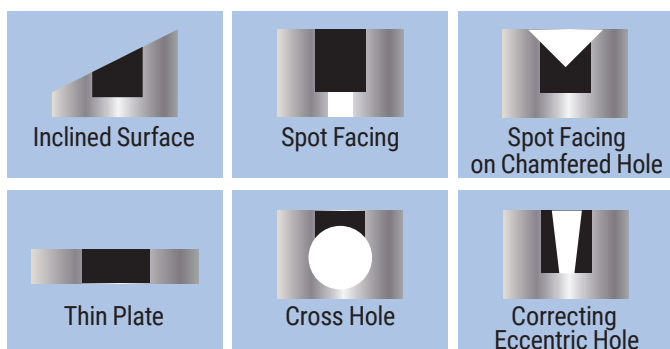

FLAT DRILL

TLD3D Type

TLD3D
TYPE

For Spot facing

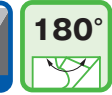

Cat.No	Stock	Dimension(mm)			
		φDc	ℓ	L	φDs
TLD3DCH0300S03	●	3.0	14	60	3
TLD3DCH0310S04	●	3.1			
TLD3DCH0320S04	●	3.2	15		
TLD3DCH0330S04	●	3.3			
TLD3DCH0340S04	●	3.4	16		
TLD3DCH0350S04	●	3.5			
TLD3DCH0360S04	●	3.6	17		
TLD3DCH0370S04	●	3.7			
TLD3DCH0380S04	●	3.8	18		
TLD3DCH0390S04	●	3.9			
TLD3DCH0400S04	●	4.0	19		
TLD3DCH0410S05	●	4.1			
TLD3DCH0420S05	●	4.2	20		
TLD3DCH0430S05	●	4.3			
TLD3DCH0440S05	●	4.4	21		
TLD3DCH0450S05	●	4.5			
TLD3DCH0460S05	●	4.6	22		
TLD3DCH0470S05	●	4.7			
TLD3DCH0480S05	●	4.8	23		
TLD3DCH0490S05	●	4.9			
TLD3DCH0500S05	●	5.0	24		
TLD3DCH0510S06	●	5.1			
TLD3DCH0520S06	●	5.2	25		
TLD3DCH0530S06	●	5.3			
TLD3DCH0540S06	●	5.4	26		
TLD3DCH0550S06	●	5.5			
TLD3DCH0560S06	●	5.6	27		
TLD3DCH0570S06	●	5.7			
TLD3DCH0580S06	●	5.8	28		
TLD3DCH0590S06	●	5.9			
TLD3DCH0600S06	●	6.0	75	7	
TLD3DCH0610S07	●	6.1			
TLD3DCH0620S07	●	6.2			

Cat.No	Stock	Dimension(mm)			
		φDc	ℓ	L	φDs
TLD3DCH0630S07	●	6.3	29	75	7
TLD3DCH0640S07	●	6.4			
TLD3DCH0650S07	●	6.5	30		
TLD3DCH0660S07	●	6.6			
TLD3DCH0670S07	●	6.7	31		
TLD3DCH0680S07	●	6.8			
TLD3DCH0690S07	●	6.9	32		
TLD3DCH0700S07	●	7.0			
TLD3DCH0710S08	●	7.1	33		
TLD3DCH0720S08	●	7.2			
TLD3DCH0730S08	●	7.3	34		
TLD3DCH0740S08	●	7.4			
TLD3DCH0750S08	●	7.5	35		
TLD3DCH0760S08	●	7.6			
TLD3DCH0770S08	●	7.7	36		
TLD3DCH0780S08	●	7.8			
TLD3DCH0790S08	●	7.9	37		
TLD3DCH0800S08	●	8.0			
TLD3DCH0810S09	●	8.1	38		
TLD3DCH0820S09	●	8.2			
TLD3DCH0830S09	●	8.3	39		
TLD3DCH0840S09	●	8.4			
TLD3DCH0850S09	●	8.5	40		
TLD3DCH0860S09	●	8.6			
TLD3DCH0870S09	●	8.7	41		
TLD3DCH0880S09	●	8.8			
TLD3DCH0890S09	●	8.9	42		
TLD3DCH0900S09	●	9.0			
TLD3DCH0910S10	●	9.1	43		
TLD3DCH0920S10	●	9.2			
TLD3DCH0930S10	●	9.3	95	10	
TLD3DCH0940S10	●	9.4			
TLD3DCH0950S10	●	9.5			

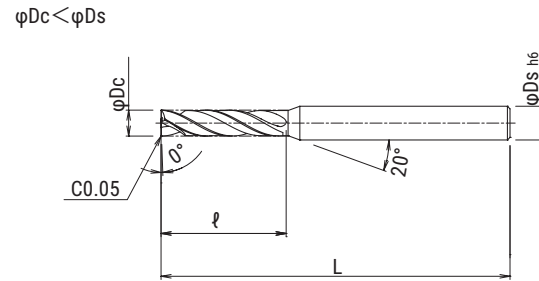
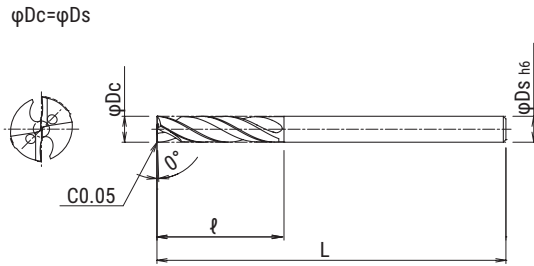

Cat.No	Stock	Dimension(mm)					
		φD_c	ℓ	L	φD_s		
TLD3DCH0960S10	●	9.6	44	95	10		
TLD3DCH0970S10	●	9.7					
TLD3DCH0980S10	●	9.8					
TLD3DCH0990S10	●	9.9					
TLD3DCH1000S10	●	10.0	45	105	11		
TLD3DCH1010S11	●	10.1					
TLD3DCH1020S11	●	10.2					
TLD3DCH1030S11	●	10.3					
TLD3DCH1040S11	●	10.4					
TLD3DCH1050S11	●	10.5					
TLD3DCH1060S11	●	10.6					
TLD3DCH1070S11	●	10.7					
TLD3DCH1080S11	●	10.8					
TLD3DCH1090S11	●	10.9					
TLD3DCH1100S11	●	11.0	50			115	12
TLD3DCH1110S12	●	11.1					
TLD3DCH1120S12	●	11.2					
TLD3DCH1130S12	●	11.3					
TLD3DCH1140S12	●	11.4					
TLD3DCH1150S12	●	11.5					
TLD3DCH1160S12	●	11.6					
TLD3DCH1170S12	●	11.7					
TLD3DCH1180S12	●	11.8					
TLD3DCH1190S12	●	11.9					
TLD3DCH1200S12	●	12.0	54	125	13		
TLD3DCH1250S13	●	12.5					
TLD3DCH1300S13	●	13.0					
TLD3DCH1350S14	●	13.5					
TLD3DCH1400S14	●	14.0					
			63			130	14

Drill dia.	Tolerance
$D_c \leq 3$	0
	-0.01
$3 < D_c \leq 6$	0
	-0.012
$6 < D_c \leq 10$	0
	-0.015
$10 < D_c$	0
	-0.018

FLAT DRILL

TLD5D Type

TLD5D
TYPE

For Spot facing

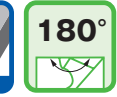

Cat.No	Stock	Dimension(mm)			
		φDc	ℓ	L	φDs
TLD5DCH0300S03	○	3.0	20	70	3
TLD5DCH0310S04	○	3.1	21		4
TLD5DCH0320S04	○	3.2	22		
TLD5DCH0330S04	○	3.3			
TLD5DCH0340S04	○	3.4	23		
TLD5DCH0350S04	○	3.5	24		
TLD5DCH0360S04	○	3.6			
TLD5DCH0370S04	○	3.7	25		
TLD5DCH0380S04	○	3.8	26		
TLD5DCH0390S04	○	3.9			
TLD5DCH0400S04	○	4.0	27	80	5
TLD5DCH0410S05	○	4.1	28		
TLD5DCH0420S05	○	4.2			
TLD5DCH0430S05	○	4.3	29		
TLD5DCH0440S05	○	4.4	30		
TLD5DCH0450S05	○	4.5			
TLD5DCH0460S05	○	4.6	31		
TLD5DCH0470S05	○	4.7	32		
TLD5DCH0480S05	○	4.8			
TLD5DCH0490S05	○	4.9	33		
TLD5DCH0500S05	○	5.0	34		
TLD5DCH0510S06	○	5.1			
TLD5DCH0520S06	○	5.2	35		
TLD5DCH0530S06	○	5.3	36		
TLD5DCH0540S06	○	5.4			
TLD5DCH0550S06	○	5.5	37		
TLD5DCH0560S06	○	5.6	38		
TLD5DCH0570S06	○	5.7			
TLD5DCH0580S06	○	5.8	39		
TLD5DCH0590S06	○	5.9	40		
TLD5DCH0600S06	○	6.0			
TLD5DCH0610S07	○	6.1	41		
TLD5DCH0620S07	○	6.2	42		

Cat.No	Stock	Dimension(mm)			
		φDc	ℓ	L	φDs
TLD5DCH0630S07	○	6.3	42	95	7
TLD5DCH0640S07	○	6.4	43		
TLD5DCH0650S07	○	6.5	44		
TLD5DCH0660S07	○	6.6			
TLD5DCH0670S07	○	6.7	45		
TLD5DCH0680S07	○	6.8	46		
TLD5DCH0690S07	○	6.9			
TLD5DCH0700S07	○	7.0	47		
TLD5DCH0710S08	○	7.1	48		
TLD5DCH0720S08	○	7.2			
TLD5DCH0730S08	○	7.3	49		
TLD5DCH0740S08	○	7.4	50		
TLD5DCH0750S08	○	7.5			
TLD5DCH0760S08	○	7.6	51		
TLD5DCH0770S08	○	7.7	52		
TLD5DCH0780S08	○	7.8			
TLD5DCH0790S08	○	7.9	53		
TLD5DCH0800S08	○	8.0	54		
TLD5DCH0810S09	○	8.1			
TLD5DCH0820S09	○	8.2	55		
TLD5DCH0830S09	○	8.3	56		
TLD5DCH0840S09	○	8.4			
TLD5DCH0850S09	○	8.5	57		
TLD5DCH0860S09	○	8.6	58		
TLD5DCH0870S09	○	8.7			
TLD5DCH0880S09	○	8.8	59		
TLD5DCH0890S09	○	8.9	60		
TLD5DCH0900S09	○	9.0			
TLD5DCH0910S10	○	9.1	61		
TLD5DCH0920S10	○	9.2	62		
TLD5DCH0930S10	○	9.3			
TLD5DCH0940S10	○	9.4	63		
TLD5DCH0950S10	○	9.5	64		

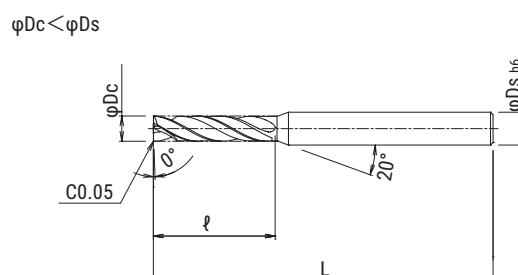
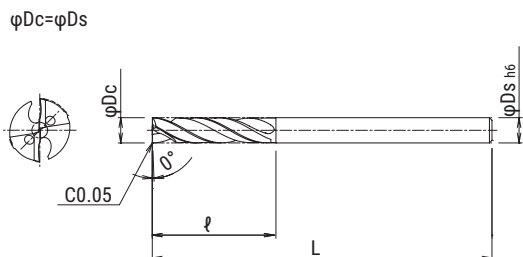

Cat.No	Stock	Dimension(mm)			
		φDc	ℓ	L	φDs
TLD5DCH0960S10	○	9.6	64	120	10
TLD5DCH0970S10	○	9.7	65		
TLD5DCH0980S10	○	9.8	66		
TLD5DCH0990S10	○	9.9			
TLD5DCH1000S10	○	10.0	67		
TLD5DCH1010S11	○	10.1	68	130	11
TLD5DCH1020S11	○	10.2			
TLD5DCH1030S11	○	10.3	69		
TLD5DCH1040S11	○	10.4	70		
TLD5DCH1050S11	○	10.5			
TLD5DCH1060S11	○	10.6	71		
TLD5DCH1070S11	○	10.7	72		
TLD5DCH1080S11	○	10.8			
TLD5DCH1090S11	○	10.9	73		
TLD5DCH1100S11	○	11.0	74		
TLD5DCH1110S12	○	11.1			
TLD5DCH1120S12	○	11.2	75		
TLD5DCH1130S12	○	11.3	76		
TLD5DCH1140S12	○	11.4			
TLD5DCH1150S12	○	11.5	77		
TLD5DCH1160S12	○	11.6	78		
TLD5DCH1170S12	○	11.7			
TLD5DCH1180S12	○	11.8	79		
TLD5DCH1190S12	○	11.9	80	155	13
TLD5DCH1200S12	○	12.0			
TLD5DCH1250S13	○	12.5	84		
TLD5DCH1300S13	○	13.0	87		
TLD5DCH1350S14	○	13.5	90		
TLD5DCH1400S14	○	14.0	94	160	14

Drill dia.	Tolerance
Dc ≤ 3	0
	-0.01
3 < Dc ≤ 6	0
	-0.012
6 < Dc ≤ 10	0
	-0.015
10 < Dc	0
	-0.018

FLAT DRILL

TLD3D/TLD5D Type

Recommended Cutting Conditions

● TLD3D type

Material	Structural Steel below 180HB	Carbon Steel below 280HB	Alloy Steel 280-350HB	Mold Steel 38-43HRC	Hardened Steel below 50HRC
Vc (m/min)	50 - 100	50 - 100	50 - 80	20 - 50	20 - 50
f (mm/rev)	0.06 - 0.24	0.06 - 0.24	0.06 - 0.24	0.06 - 0.20	0.08 - 0.20

Material	Titanium Alloy	Stainless Steel	Grey Cast Iron	Nodular Cast Iron	Aluminium Alloy
Vc (m/min)	20 - 50	25 - 50	50 - 100	50 - 100	120 - 200
f (mm/rev)	0.06 - 0.20	0.06 - 0.20	0.06 - 0.24	0.06 - 0.24	0.05 - 0.15

Note

1. These cutting conditions are for drilling flat surface. when drilling angled surfaces, parameters should be adjusted.
For inclined angle under 30°, apply 40-80% of (Vf) and for inclined angle 30° or more, apply 20-50% of (Vf) from standard cutting conditions.
2. Use water-soluble coolant. In case of external coolant, use step feed.
3. Drilling over 3 x Dc is not recommended.
4. Side milling is not possible.
5. In case of long chips, adjust parameters by increasing (Vf) or using step feed for breaking chips.

● TLD5D type

Material	Structural Steel below 180HB	Carbon Steel below 280HB	Alloy Steel 280-350HB	Mold Steel 38-43HRC	Hardened Steel below 50HRC
Vc (m/min)	50 - 100	50 - 100	50 - 80	20 - 50	30 - 50
f (mm/rev)	0.06 - 0.24	0.06 - 0.24	0.06 - 0.24	0.06 - 0.20	0.08 - 0.20

Material	Titanium Alloy	Stainless Steel	Grey Cast Iron	Nodular Cast Iron	Aluminium Alloy
Vc (m/min)	20 - 50	25 - 50	50 - 100	50 - 100	120 - 200
f (mm/rev)	0.06 - 0.20	0.06 - 0.20	0.06 - 0.24	0.06 - 0.24	0.05 - 0.15

Note

1. These cutting conditions are applied only on the condition that guide-hole drilled (0.5-1.0D depth).
2. Use water-soluble coolant. In case of external coolant, use step feed.
3. Drilling over 5 x Dc is not recommended.
4. Side milling is not possible.
5. In case of long chips, adjust parameters by increasing (Vf) or using step feed for breaking chips.

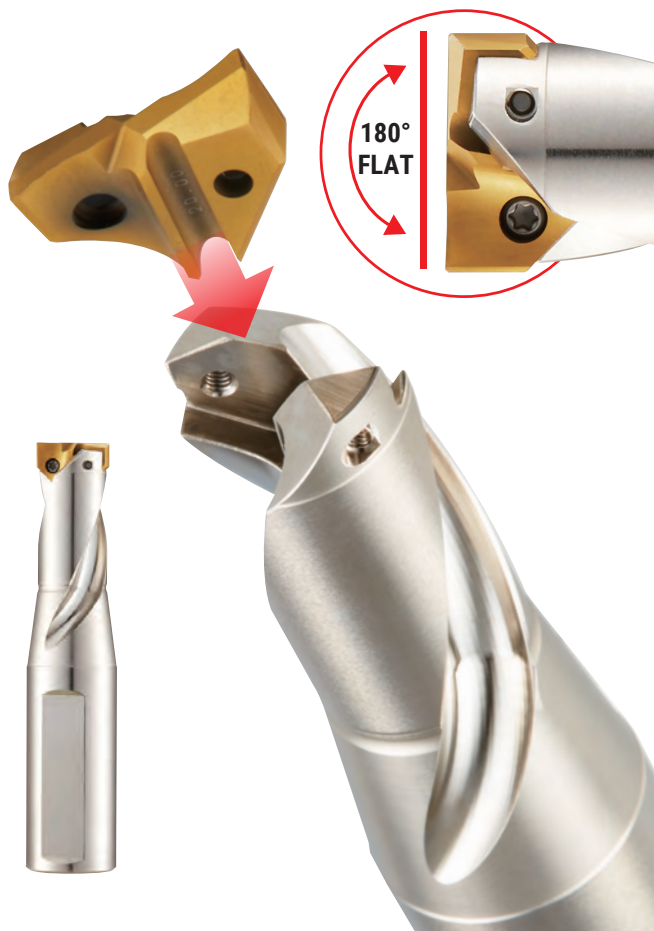

- 180° Flat face
- Able to drill without pilot hole, even on sloped surfaces & cross holes

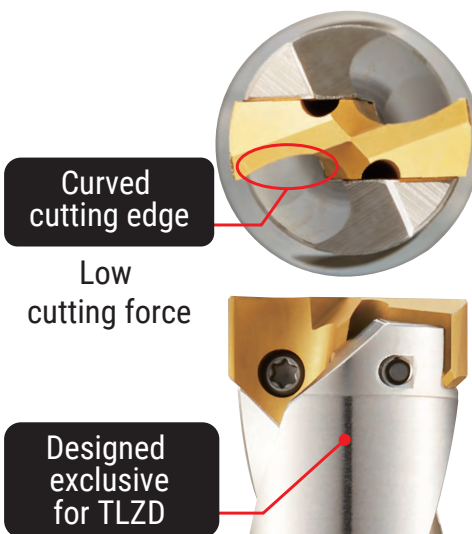

Curved cutting edge

Low cutting force

Designed exclusive for TLZD

■ Features

- 1 Easy tool management
- 2 Able to drill without pilot hole, even on sloped surfaces and cross holes.
- 3 Long tool life by adopting new grade JC7550 and improved coolant distribution system.
- 4 The most suitable for burr-less processing.

■ Applications

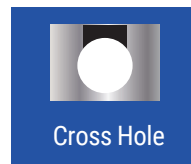
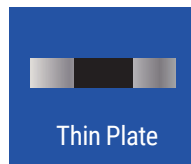
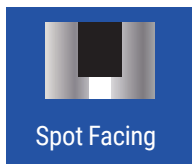

INDEXABLE FLAT DRILL

TLZD Type

TLZD
TYPE

Holder

● Depth of hole: 1.5×Dc



$\varphi D_c \leq \varphi 30$

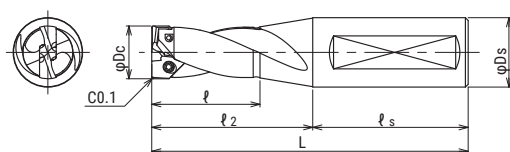

$\varphi D_c > \varphi 30$

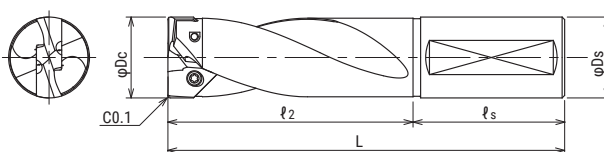

Cat.No.	Stock	Dc		Dimensions (mm)					Parts	
		Min.	Max.	ℓ	ℓ_2	ℓ_s	L	D_s	Screw	Wrench
TLZD1400S16-SS	●	14.0	14.5	29	43	48	91	16	DSW-2045H	A-07
TLZD1500S20-SS	●	14.6	15.5	31	46	50	96	20		
TLZD1600S20-SS	●	15.6	16.5	33	49	50	99	20	TSW-2556H	A-08
TLZD1700S20-SS	●	16.6	17.5	35	52	50	102	20		
TLZD1800S20-SS	●	17.6	18.5	37	55	50	105	20	TSW-2567H	A-08
TLZD1900S25-SS	●	18.6	19.5	39	58	56	114	25		
TLZD2000S25-SS	●	19.6	20.5	41	61	56	117	25	DSW-307H	A-10
TLZD2100S25-SS	●	21.0	21.5	43	64	56	120	25		
TLZD2200S25-SS	●	22.0	22.5	45	67	56	123	25	DSW-309H	A-10
TLZD2300S25-SS	●	23.0	23.5	47	70	56	126	25		
TLZD2400S32-SS	●	24.0	24.5	49	73	60	133	32	TSW-3510H	A-15
TLZD2500S32-SS	●	25.0	25.5	51	76	60	136	32		
TLZD2600S32-SS	●	26.0	26.5	53	79	60	139	32	TSW-3512H	A-15
TLZD2700S32-SS	●	27.0	27.5	55	82	60	142	32		
TLZD2800S32-SS	●	28.0	28.5	57	85	60	145	32	TSW-3512H	A-15
TLZD2900S32-SS	●	29.0	29.5	59	88	60	148	32		
TLZD3000S32-SS	●	30.0	30.5	61	91	60	151	32	TSW-3512H	A-15
TLZD3100S32-SS	●	31.0	31.5	-	94	60	154	32		
TLZD3200S32-SS	●	32.0	-	-	97	60	157	32		

INDEXABLE FLAT DRILL

TLZD Type

TLZD
TYPE

Modular Type

● Depth of hole 0.7~1xDc

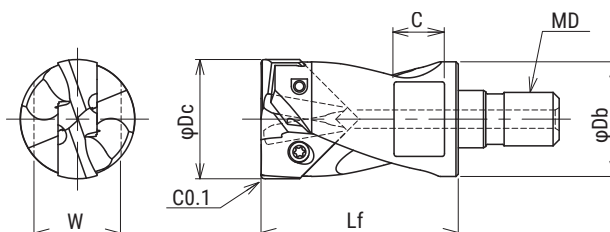

Cat.No.	Stock	Dc		Dimensions (mm)					Parts		MSN Carbide Shank
		Min.	Max.	Lf	Db	MD	C	W	Screw	Wrench	
TLZD1400-M6	●	14.0	14.5	27.5	13.1	M6	7	10	DSW-2045H	A-07	MSN-M6-**-S16C
TLZD1500-M8	●	14.6	15.5	29.5	14	M8	8	12			MSN-M8-**-S14C
TLZD1600-M8	●	15.6	16.5	29.5	15	M8	8	12	TSW-2556H	A-08	MSN-M8-**-S15C
TLZD1700-M8	●	16.6	17.5	30.5	16	M8	8	12			MSN-M8-**-S16C
TLZD1800-M8	●	17.6	18.5	30.5	17	M8	8	12	TSW-2567H	A-08	MSN-M8-**-S16C
TLZD1900-M10	●	18.6	19.5	38.5	18	M10	9	14			MSN-M10-**-S18C
TLZD2000-M10	●	19.6	20.5	38.5	19	M10	9	14	TSW-2567H	A-08	MSN-M10-**-S20C
TLZD2100-M10	●	21.0	21.5	38.5	20	M10	9	14			MSN-M10-**-S20C
TLZD2200-M10	●	22.0	22.5	38.5	21	M10	9	14	DSW-307H	A-10	MSN-M10-**-S20C
TLZD2300-M10	●	23.0	23.5	38.5	22	M10	9	14			MSN-M10-**-S20C
TLZD2400-M12	●	24.0	24.5	43	23	M12	11	19	DSW-309H	A-10	MSN-M12-**-S23C
TLZD2500-M12	●	25.0	25.5	43	24	M12	11	19			MSN-M12-**-S25C
TLZD2600-M12	●	26.0	26.5	43	25	M12	11	19	DSW-309H	A-10	MSN-M12-**-S25C
TLZD2700-M12	●	27.0	27.5	43	26	M12	11	19			MSN-M12-**-S25C
TLZD2800-M12	●	28.0	28.5	43	27	M12	11	19	TSW-3510H	A-15	MSN-M12-**-S25C
TLZD2900-M16	●	29.0	29.5	51	28	M16	12	22			MSN-M16-**-S28C
TLZD3000-M16	●	30.0	30.5	51	29	M16	12	22	TSW-3512H	A-15	MSN-M16-**-S32C
TLZD3100-M16	●	31.0	31.5	51	30	M16	12	22			MSN-M16-**-S32C
TLZD3200-M16	●	32.0	-	51	31	M16	14	26	TSW-3512H	A-15	MSN-M16-**-S32C

Screw	Torque (N·m)
DSW-2045H	0.9
TSW-2556H	1.2
TSW-2567H	1.2
DSW-307H	2.1
DSW-309H	2.1
TSW-3510H	3.0
TSW-3512H	3.0

INDEXABLE FLAT DRILL

TLZD Type

TLZ
TYPE

Insert - Grade JC7550

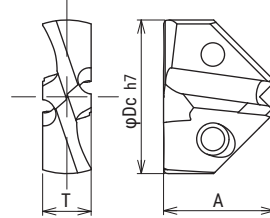
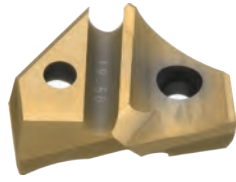

Dc	Cat.No.	Stk	A	T	Holder
14.0	TLZ1400	●	10.6	4.5	TLZD14*
14.1	TLZ1410	●			
14.2	TLZ1420	●			
14.3	TLZ1430	●			
14.4	TLZ1440	●			
14.5	TLZ1450	●			
14.6	TLZ1460	●	11.3	4.8	TLZD15*
14.7	TLZ1470	●			
14.8	TLZ1480	●			
14.9	TLZ1490	●			
15.0	TLZ1500	●			
15.1	TLZ1510	●			
15.2	TLZ1520	●			
15.3	TLZ1530	●			
15.4	TLZ1540	●			
15.5	TLZ1550	●			
15.6	TLZ1560	●	12.1	5.0	TLZD16*
15.7	TLZ1570	●			
15.8	TLZ1580	●			
15.9	TLZ1590	●			
16.0	TLZ1600	●			
16.1	TLZ1610	●			
16.2	TLZ1620	●			
16.3	TLZ1630	●			
16.4	TLZ1640	●			
16.5	TLZ1650	●			
16.6	TLZ1660	●	12.6	5.5	TLZD17*
16.7	TLZ1670	●			
16.8	TLZ1680	●			
16.9	TLZ1690	●			
17.0	TLZ1700	●			
17.1	TLZ1710	●			
17.2	TLZ1720	●			
17.3	TLZ1730	●			
17.4	TLZ1740	●			
17.5	TLZ1750	●			
17.6	TLZ1760	●	13.2	5.8	TLZD18*
17.7	TLZ1770	●			
17.8	TLZ1780	●			
17.9	TLZ1790	●			
18.0	TLZ1800	●			
18.1	TLZ1810	●			
18.2	TLZ1820	●			

Dc	Cat.No.	Stk	A	T	Holder
18.3	TLZ1830	●	13.2	5.8	TLZD18*
18.4	TLZ1840	●			
18.5	TLZ1850	●			
18.6	TLZ1860	●	13.6	6.0	TLZD19*
18.7	TLZ1870	●			
18.8	TLZ1880	●			
18.9	TLZ1890	●			
19.0	TLZ1900	●			
19.1	TLZ1910	●			
19.2	TLZ1920	●			
19.3	TLZ1930	●			
19.4	TLZ1940	●			
19.5	TLZ1950	●			
19.6	TLZ1960	●	14.6	6.5	TLZD20*
19.7	TLZ1970	●			
19.8	TLZ1980	●			
19.9	TLZ1990	●			
20.0	TLZ2000	●			
20.5	TLZ2050	●			
21.0	TLZ2100	●	15.2	6.7	TLZD21*
21.5	TLZ2150	●			
22.0	TLZ2200	●	15.9	7.5	TLZD22*
22.5	TLZ2250	●			
23.0	TLZ2300	●	16.7	7.5	TLZD23*
23.5	TLZ2350	●			
24.0	TLZ2400	●	17.4	8.0	TLZD24*
24.5	TLZ2450	●			
25.0	TLZ2500	●	18.3	8.0	TLZD25*
25.5	TLZ2550	●			
26.0	TLZ2600	●	18.8	8.5	TLZD26*
26.5	TLZ2650	●			
27.0	TLZ2700	●	19.5	8.5	TLZD27*
27.5	TLZ2750	●			
28.0	TLZ2800	●	20.3	9.0	TLZD28*
28.5	TLZ2850	●			
29.0	TLZ2900	●	21.1	9.0	TLZD29*
29.5	TLZ2950	●			
30.0	TLZ3000	●	21.5	9.5	TLZD30*
30.5	TLZ3050	●			
31.0	TLZ3100	●	22.3	10.0	TLZD31*
31.5	TLZ3150	●			
32.0	TLZ3200	●	23.1	10.0	TLZD32*

■ Recommended Cutting Conditions

● TLZD-SS type

Material	Mild Steel below 180HB	Carbon Steel below 280HB	Tool Steel below 255HB	Alloy Steel 280-350HB
Vc (m/min)	50 - 70 - 100	50 - 70 - 100	30 - 50 - 70	30 - 50 - 70
f (mm/rev)	0.06 - 0.20 (Dc14-16) 0.07 - 0.21 (Dc17-20) 0.08 - 0.22 (Dc21-25) 0.09 - 0.23 (Dc26-29) 0.10 - 0.24 (Dc30-32)	0.06 - 0.20 (Dc14-16) 0.07 - 0.21 (Dc17-20) 0.08 - 0.22 (Dc21-25) 0.09 - 0.23 (Dc26-29) 0.10 - 0.24 (Dc30-32)	0.06 - 0.20 (Dc14-16) 0.07 - 0.21 (Dc17-20) 0.08 - 0.22 (Dc21-25) 0.09 - 0.23 (Dc26-29) 0.10 - 0.24 (Dc30-32)	0.06 - 0.20 (Dc14-16) 0.07 - 0.21 (Dc17-20) 0.08 - 0.22 (Dc21-25) 0.09 - 0.23 (Dc26-29) 0.10 - 0.24 (Dc30-32)

Material	Mild Steel below 40HRC	Cast Iron	Stainless Steel	Aluminium Alloy
Vc (m/min)	20 - 30 - 40	50 - 70 - 100	80 - 100 - 120 - 140	50 - 100 - 150
f (mm/rev)	0.04 - 0.10 (Dc14-16) 0.04 - 0.11 (Dc17-18) 0.05 - 0.11 (Dc19-20) 0.05 - 0.12 (Dc21-25) 0.05 - 0.13 (Dc26-27) 0.06 - 0.13 (Dc28-29) 0.06 - 0.14 (Dc30-32)	0.06 - 0.20 (Dc14-16) 0.07 - 0.21 (Dc17-20) 0.08 - 0.22 (Dc21-25) 0.09 - 0.23 (Dc26-29) 0.10 - 0.24 (Dc30-32)	0.02 - 0.06 (Dc14-18) 0.03 - 0.07 (Dc19-25) 0.04 - 0.08 (Dc26-31) 0.05 - 0.09 (Dc32)	0.06 - 0.20 (Dc14-16) 0.07 - 0.21 (Dc17-20) 0.08 - 0.22 (Dc21-25) 0.09 - 0.23 (Dc26-29) 0.10 - 0.24 (Dc30-32)

Note

1. These cutting conditions are for drilling flat surface. when drilling angled surfaces, parameters should be adjusted.
For inclined angle under 30°, apply 40-80% of (Vf) and for inclined angle 30° or more , apply 20-50% of (Vf) from standard cutting conditions.
2. These cutting conditions are for drilling with water soluble coolant. when dry cutting , use air to remove chips.
3. Drilling depth over 1.5 x Dc is not recommended.
4. Side milling is not possible.
5. In case of long chips , adjust parameters by increasing (Vf) or using step feed for breaking chips.

INDEXABLE FLAT DRILL

TLZD Type

■ Recommended Cutting Conditions

● TLZD-***-M** Modular Head type

Material	Mild Steel below 180HB	Carbon Steel below 280HB	Tool Steel below 255HB	Alloy Steel 280-350HB
Vc (m/min)	70	70	70	70
f (mm/rev)	0.04 - 0.06 (Dc14) 0.04 - 0.08 (Dc15-18) 0.04 - 0.09 (Dc19-23) 0.06 - 0.12 (Dc24-28) 0.06 - 0.14 (Dc29-32)	0.04 - 0.06 (Dc14) 0.04 - 0.08 (Dc15-18) 0.04 - 0.09 (Dc19-23) 0.06 - 0.12 (Dc24-28) 0.06 - 0.14 (Dc29-32)	0.03 - 0.05 (Dc14) 0.03 - 0.06 (Dc15-18) 0.04 - 0.07 (Dc19-23) 0.05 - 0.09 (Dc24-28) 0.06 - 0.11 (Dc29-32)	0.03 - 0.05 (Dc14) 0.03 - 0.06 (Dc15-18) 0.04 - 0.07 (Dc19-23) 0.05 - 0.09 (Dc24-28) 0.06 - 0.11 (Dc29-32)

Material	Mold Steel below 40HRC	Cast Iron	Stainless Steel	Aluminium Alloy
Vc (m/min)	40	100	100	100
f (mm/rev)	0.02 - 0.06 (Dc14) 0.03 - 0.07 (Dc15-18) 0.03 - 0.08 (Dc19-23) 0.04 - 0.10 (Dc24-28) 0.05 - 0.13 (Dc29-32)	0.02 - 0.07 (Dc14) 0.04 - 0.09 (Dc15-18) 0.02 - 0.10 (Dc19-23) 0.02 - 0.12 (Dc24-28) 0.02 - 0.13 (Dc29-32)	0.02 - 0.04 (Dc14-23) 0.03 - 0.04 (Dc24-32)	0.02 - 0.07 (Dc14) 0.04 - 0.09 (Dc15-18) 0.02 - 0.10 (Dc19-23) 0.02 - 0.12 (Dc24-28) 0.02 - 0.13 (Dc29-32)

Note

1. These cutting conditions are for drilling flat surface. when drilling angled surfaces, parameters should be adjusted.
for inclined angle under 30°, apply 40-80% of (Vf) and for inclined angle 30° or more , apply 20-50% of (Vf) from standard cutting conditions.
2. These cutting conditions are for drilling with water soluble coolant. when dry cutting , use air to remove chips.
3. Drilling depth over 1.0 x Dc is not recommended.
4. Side milling is not possible.
5. In case of long chips , adjust parameters by increasing (Vf) or using step feed for breaking chips.
when drilling stainless steel, increasing (Vf) is not recommended to break chips. Increase (Vc) and reduce (Vf) so that bellows-shaped chips can occur.

PROCEDURE FOR MOUNTING INSERT

1. Removing used insert

Make sure to remove any chips or dust off the tip before removing the used insert. Remove used insert and clean pocket using a brush or air blowing before loading new insert.

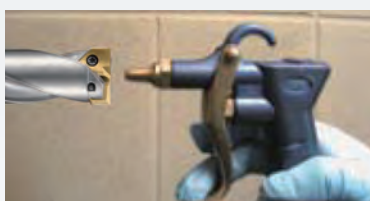

2. Loading new insert

Place new insert in pocket, lightly tighten two screws while pressing the top of the insert (see photo). After confirming there is no gap between the drill and insert, tighten the insert screw, starting with the same screw you first lightly tightened, to the recommended torque while still pressing the top of the insert.

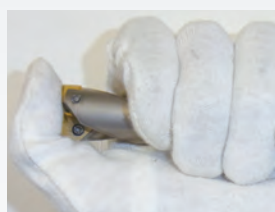

"MOLY"
(Sold separately)

⚠ Note:

Clamp screw needs to be changed out after replacing the insert approximately 10 times or if you see any issues with the screws.



Clamp screw

■ HOLE BOTTOM SHAPE

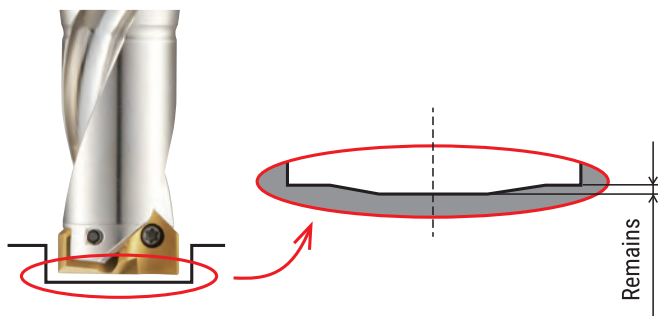

Tool dia. (mm)	Remains (mm)
φ14~φ20.5	0.04~0.06
φ21~φ26.5	0.05~0.07
φ27~φ32.0	0.06~0.08

INDEXABLE DRILL **TEZD Type**



EASY ASSEMBLY AND HIGH PERFORMANCE

ECO-FRIENDLY

Unique low cutting geometry reduces power consumption.

ECONOMICAL

Save tool cost compared with using solid carbide drill

HIGH CUTTING PERFORMANCE

Distinctive cooling system ensures coolant is supplied to cutting edge.



■ LINE UP

Holder	Depth of hole	Diameter
TEZD-MS Type	3xDc	φ13.5~φ32.5
TEZD-ML Type	5xDc	
TEZD-XL Type	8xDc	

PROCEDURE FOR MOUNTING INSERT

1. Removing used insert

Make sure to remove any chips or dust off the tip before removing the used insert. Remove used insert and clean pocket using a brush or air blowing before loading new insert.



2. Loading new insert

Place new insert in pocket, lightly tighten two screws while pressing the top of the insert (see photo). After confirming there is no gap between the drill and insert, tighten the insert screw, starting with the same screw you first lightly tightened, to the recommended torque while still pressing the top of the insert.



"MOLY"
(Sold separately)

Note:

Clamp screw need to be changed out after replacing the insert approximately 10 times or if you see any issues with the screws.



Clamp screw

IF USING LATHE MACHINE

1. Check run out of insert O.D. within 0.03mm (off set of center 0.015mm) and flute O.D. of shank side within approx. 0.03mm.
2. Due to large thrust of cutting forces, make sure drill is fully seated in holder.
3. Reduce the cutting speed and feed rate by 20% from standard cutting conditions.

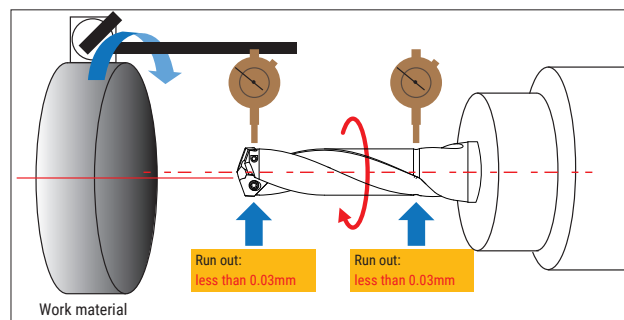

INDEXABLE DRILL

TEZD Type



TEZD-MS
TYPE

Holder

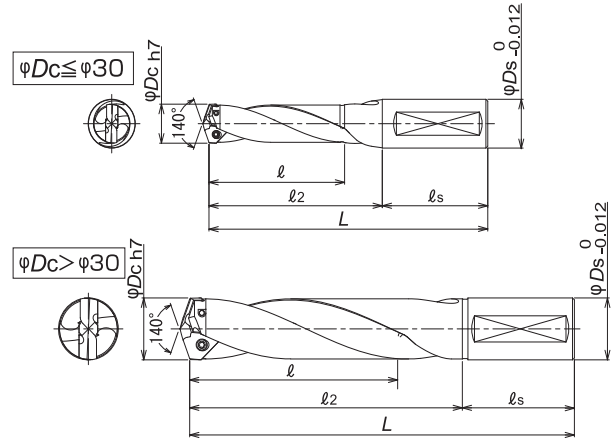

Cat.No.	Stock	Dc		Dimensions (mm)					Parts	
		Min.	Max.	ℓ	ℓ2	ℓs	L	Ds	Screw	Wrench
TEZD1400S16-MS	●	13.5	14.5	51	65	48	113	16	DSW-2045H	A-07
TEZD1500S20-MS	●	14.6	15.5	54	69	50	119	20		
TEZD1600S20-MS	●	15.6	16.5	58	74	50	124	20	TSW-2556H	A-08
TEZD1700S20-MS	●	16.6	17.5	61	78	50	128	20		
TEZD1800S20-MS	●	17.6	18.5	65	83	50	133	20	TSW-2567H	A-08
TEZD1900S25-MS	●	18.6	19.5	68	87	56	143	25		
TEZD2000S25-MS	●	19.6	20.5	72	92	56	148	25	DSW-307H	A-10
TEZD2100S25-MS	●	20.6	21.5	75	96	56	152	25		
TEZD2200S25-MS	●	21.6	22.5	79	101	56	157	25	DSW-309H	A-10
TEZD2300S25-MS	●	22.6	23.5	82	105	56	161	25		
TEZD2400S32-MS	●	23.6	24.5	86	110	60	170	32	TSW-3510H	A-15
TEZD2500S32-MS	●	24.6	25.5	89	114	60	174	32		
TEZD2600S32-MS	●	25.6	26.5	93	119	60	179	32	TSW-3512H	A-15
TEZD2700S32-MS	●	26.6	27.5	96	123	60	183	32		
TEZD2800S32-MS	●	27.6	28.5	100	128	60	188	32		
TEZD2900S32-MS	●	28.6	29.5	103	132	60	192	32		
TEZD3000S32-MS	●	29.6	30.5	107	137	60	197	32		
TEZD3100S32-MS	●	30.6	31.5	110	141	60	201	32		
TEZD3200S32-MS	●	31.6	32.5	114	146	60	206	32		

TEZD-ML
TYPE

Holder

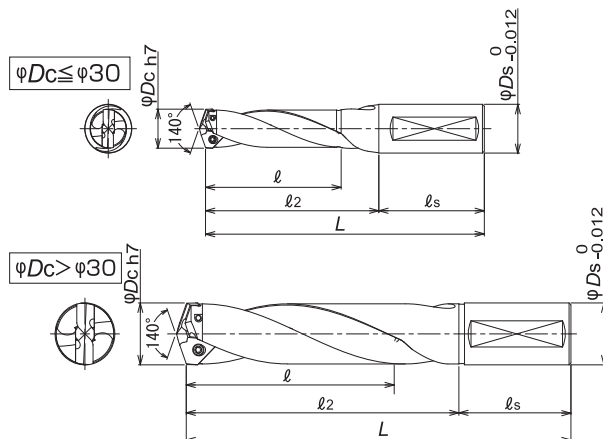

Cat.No.	Stock	Dc		Dimensions (mm)					Parts	
		Min.	Max.	ℓ	ℓ_2	ℓ_s	L	Ds	Screw	Wrench
TEZD1400S16-ML	●	13.5	14.5	80	97	48	145	16	DSW-2045H	A-07
TEZD1500S20-ML	●	14.6	15.5	85	103	50	153	20		
TEZD1600S20-ML	●	15.6	16.5	91	110	50	160	20	TSW-2556H	A-08
TEZD1700S20-ML	●	16.6	17.5	96	117	50	167	20		
TEZD1800S20-ML	●	17.6	18.5	102	123	50	173	20	TSW-2567H	A-08
TEZD1900S25-ML	●	18.6	19.5	107	130	56	186	25		
TEZD2000S25-ML	●	19.6	20.5	113	137	56	193	25	DSW-307H	A-10
TEZD2100S25-ML	●	20.6	21.5	118	143	56	199	25		
TEZD2200S25-ML	●	21.6	22.5	124	150	56	206	25	DSW-309H	A-10
TEZD2300S25-ML	●	22.6	23.5	129	157	56	213	25		
TEZD2400S32-ML	●	23.6	24.5	135	164	60	224	32	TSW-3510H	A-15
TEZD2500S32-ML	●	24.6	25.5	140	170	60	230	32		
TEZD2600S32-ML	●	25.6	26.5	146	177	60	237	32	TSW-3512H	A-15
TEZD2700S32-ML	●	26.6	27.5	151	184	60	244	32		
TEZD2800S32-ML	●	27.6	28.5	157	190	60	250	32		
TEZD2900S32-ML	●	28.6	29.5	162	197	60	257	32		
TEZD3000S32-ML	●	29.6	30.5	168	204	60	264	32		
TEZD3100S32-ML	●	30.6	31.5	173	210	60	270	32		
TEZD3200S32-ML	●	31.6	32.5	179	217	60	277	32		

INDEXABLE DRILL

TEZD Type



TEZD-XL
TYPE

Holder

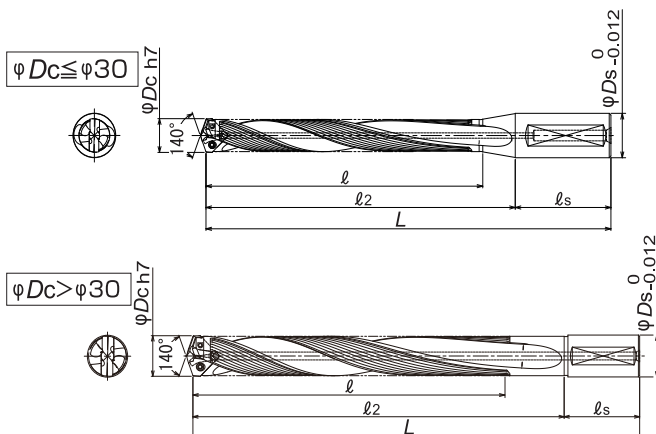

Cat.No.	Stock	Dc		Dimensions (mm)					Parts	
		Min.	Max.	l	l ₂	l _s	L	D _s	Screw	Wrench
TEZD1400S16-XL	●	13.5	14.5	119	133	48	181	16	DSW-2045H	A-07
TEZD1500S20-XL	●	14.6	15.5	128	143	50	193	20		
TEZD1600S20-XL	●	15.6	16.5	136	152	50	202	20	TSW-2556H	A-08
TEZD1700S20-XL	●	16.6	17.5	145	162	50	212	20		
TEZD1800S20-XL	●	17.6	18.5	153	171	50	221	20	TSW-2567H	A-08
TEZD1900S25-XL	●	18.6	19.5	162	181	56	237	25		
TEZD2000S25-XL	●	19.6	20.5	170	190	56	246	25	DSW-307H	A-10
TEZD2100S25-XL	●	20.6	21.5	179	200	56	256	25		
TEZD2200S25-XL	●	21.6	22.5	187	209	56	265	25	DSW-309H	A-10
TEZD2300S25-XL	●	22.6	23.5	196	219	56	275	25		
TEZD2400S32-XL	●	23.6	24.5	204	228	60	288	32	TSW-3510H	A-15
TEZD2500S32-XL	●	24.6	25.5	213	238	60	298	32		
TEZD2600S32-XL	●	25.6	26.5	221	247	60	307	32	TSW-3512H	A-15
TEZD2700S32-XL	●	26.6	27.5	230	257	60	317	32		
TEZD2800S32-XL	●	27.6	28.5	238	266	60	326	32		
TEZD2900S32-XL	●	28.6	29.5	247	276	60	336	32		
TEZD3000S32-XL	●	29.6	30.5	255	285	60	345	32		
TEZD3100S32-XL	●	30.6	31.5	248	295	60	355	32		
TEZD3200S32-XL	●	31.6	32.5	256	304	60	364	32		

INDEXABLE DRILL

TEZD Type

DRILLS

TEZ
TYPE

Insert - Grade JC8050

● Suitable for General Steel

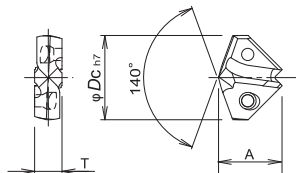
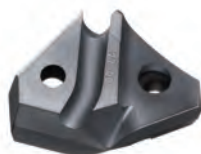

Dc	Cat.No.	Stk	A	T	Holder
13.5	TEZ1350	●	11.4	4.5	TEZD14*
13.6	TEZ1360	●			
13.7	TEZ1370	●			
13.8	TEZ1380	●			
13.9	TEZ1390	●			
14.0	TEZ1400	●			
14.1	TEZ1410	●			
14.2	TEZ1420	●			
14.3	TEZ1430	●			
14.4	TEZ1440	●			
14.5	TEZ1450	●	11.5	4.8	TEZD15*
14.6	TEZ1460	●			
14.7	TEZ1470	●			
14.8	TEZ1480	●			
14.9	TEZ1490	●			
15.0	TEZ1500	●			
15.1	TEZ1510	●			
15.2	TEZ1520	●			
15.3	TEZ1530	●			
15.4	TEZ1540	●			
15.5	TEZ1550	●	12.4	5.0	TEZD16*
15.6	TEZ1560	●			
15.7	TEZ1570	●			
15.8	TEZ1580	●			
15.9	TEZ1590	●			
16.0	TEZ1600	●			
16.1	TEZ1610	●			
16.2	TEZ1620	●			
16.3	TEZ1630	●			
16.4	TEZ1640	●			
16.5	TEZ1650	●	13.2	5.5	TEZD17*
16.6	TEZ1660	●			
16.7	TEZ1670	●			
16.8	TEZ1680	●			
16.9	TEZ1690	●			
17.0	TEZ1700	●			
17.1	TEZ1710	●			
17.2	TEZ1720	●			
17.3	TEZ1730	●			
17.4	TEZ1740	●			
17.5	TEZ1750	●	13.5	5.8	TEZD18*
17.6	TEZ1760	●			
17.7	TEZ1770	●			
17.8	TEZ1780	●			
17.9	TEZ1790	●			
18.0	TEZ1800	●			
18.1	TEZ1810	●			
18.2	TEZ1820	●			

Dc	Cat.No.	Stk	A	T	Holder
18.3	TEZ1830	●	13.5	5.8	TEZD18*
18.4	TEZ1840	●			
18.5	TEZ1850	●			
18.6	TEZ1860	●	14.2	6.0	TEZD19*
18.7	TEZ1870	●			
18.8	TEZ1880	●			
18.9	TEZ1890	●			
19.0	TEZ1900	●			
19.1	TEZ1910	●			
19.2	TEZ1920	●			
19.3	TEZ1930	●			
19.4	TEZ1940	●			
19.5	TEZ1950	●			
19.6	TEZ1960	●			
19.7	TEZ1970	●			
19.8	TEZ1980	●			
19.9	TEZ1990	●			
20.0	TEZ2000	●			
20.1	TEZ2010	●			
20.2	TEZ2020	●			
20.3	TEZ2030	●			
20.4	TEZ2040	●	15.7	6.7	TEZD21*
20.5	TEZ2050	●			
20.6	TEZ2060	●			
20.7	TEZ2070	●			
20.8	TEZ2080	●			
20.9	TEZ2090	●			
21.0	TEZ2100	●			
21.1	TEZ2110	●			
21.2	TEZ2120	●			
21.3	TEZ2130	●			
21.4	TEZ2140	●			
21.5	TEZ2150	●			
21.6	TEZ2160	●			
21.7	TEZ2170	●			
21.8	TEZ2180	●			
21.9	TEZ2190	●			
22.0	TEZ2200	●			
22.1	TEZ2210	●			
22.2	TEZ2220	●	17.4	7.5	TEZD23*
22.3	TEZ2230	●			
22.4	TEZ2240	●			
22.5	TEZ2250	●			
22.6	TEZ2260	●			
22.7	TEZ2270	●			
22.8	TEZ2280	●			
22.9	TEZ2290	●			
23.0	TEZ2300	●			

INDEXABLE DRILL TEZD Type



TEZ
TYPE

Insert - Grade JC8050

● Suitable for General Steel

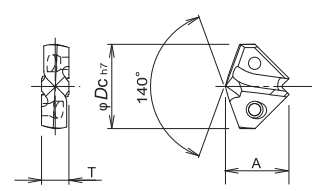

Dc	Cat.No.	Stk	A	T	Holder
23.1	TEZ2310	●	17.4	7.5	TEZD23*
23.2	TEZ2320	●			
23.3	TEZ2330	●			
23.4	TEZ2340	●			
23.5	TEZ2350	●			
23.6	TEZ2360	●	18.2	8.0	TEZD24*
23.7	TEZ2370	●			
23.8	TEZ2380	●			
23.9	TEZ2390	●			
24.0	TEZ2400	●			
24.1	TEZ2410	●			
24.2	TEZ2420	●			
24.3	TEZ2430	●			
24.4	TEZ2440	●			
24.5	TEZ2450	●			
24.6	TEZ2460	●	19.1	8.0	TEZD25*
24.7	TEZ2470	●			
24.8	TEZ2480	●			
24.9	TEZ2490	●			
25.0	TEZ2500	●			
25.1	TEZ2510	●			
25.2	TEZ2520	●			
25.3	TEZ2530	●			
25.4	TEZ2540	●			
25.5	TEZ2550	●			
25.6	TEZ2560	●	19.7	8.5	TEZD26*
25.7	TEZ2570	●			
25.8	TEZ2580	●			
25.9	TEZ2590	●			
26.0	TEZ2600	●			
26.1	TEZ2610	●			
26.2	TEZ2620	●			
26.3	TEZ2630	●			
26.4	TEZ2640	●			
26.5	TEZ2650	●			
26.6	TEZ2660	●	20.4	8.5	TEZD27*
26.7	TEZ2670	●			
26.8	TEZ2680	●			
26.9	TEZ2690	●			
27.0	TEZ2700	●			
27.1	TEZ2710	●			
27.2	TEZ2720	●			
27.3	TEZ2730	●			
27.4	TEZ2740	●			
27.5	TEZ2750	●			
27.6	TEZ2760	●	21.2	9.0	TEZD28*
27.7	TEZ2770	●			
27.8	TEZ2780	●			

Dc	Cat.No.	Stk	A	T	Holder
27.9	TEZ2790	●	21.2	9.0	TEZD28*
28.0	TEZ2800	●			
28.1	TEZ2810	●			
28.2	TEZ2820	●			
28.3	TEZ2830	●			
28.4	TEZ2840	●			
28.5	TEZ2850	●			
28.6	TEZ2860	●			
28.7	TEZ2870	●	22.1	9.0	TEZD29*
28.8	TEZ2880	●			
28.9	TEZ2890	●			
29.0	TEZ2900	●			
29.1	TEZ2910	●			
29.2	TEZ2920	●			
29.3	TEZ2930	●			
29.4	TEZ2940	●			
29.5	TEZ2950	●			
29.6	TEZ2960	●			
29.7	TEZ2970	●			
29.8	TEZ2980	●			
29.9	TEZ2990	●			
30.0	TEZ3000	●			
30.1	TEZ3010	●			
30.2	TEZ3020	●			
30.3	TEZ3030	●			
30.4	TEZ3040	●			
30.5	TEZ3050	●			
30.6	TEZ3060	●	23.4	10	TEZD31*
30.7	TEZ3070	●			
30.8	TEZ3080	●			
30.9	TEZ3090	●			
31.0	TEZ3100	●			
31.1	TEZ3110	●			
31.2	TEZ3120	●			
31.3	TEZ3130	●			
31.4	TEZ3140	●			
31.5	TEZ3150	●			
31.6	TEZ3160	●	24.3	10	TEZD32*
31.7	TEZ3170	●			
31.8	TEZ3180	●			
31.9	TEZ3190	●			
32.0	TEZ3200	●			
32.1	TEZ3210	●			
32.2	TEZ3220	●			
32.3	TEZ3230	●			
32.4	TEZ3240	●			
32.5	TEZ3250	●			

INDEXABLE DRILL

TEZD Type

DRILLS

TEZ-S
TYPE

Insert - Grade JC7515

● for Stainless steel, Titanium alloy

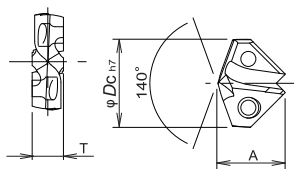

Dc	Cat.No.	Stk	A	T	Holder
13.5	TEZ1350S	●	11.4	4.5	TEZD14*
13.6	TEZ1360S	●			
13.7	TEZ1370S	●			
13.8	TEZ1380S	●			
13.9	TEZ1390S	●			
14.0	TEZ1400S	●			
14.1	TEZ1410S	●			
14.2	TEZ1420S	●			
14.3	TEZ1430S	●			
14.4	TEZ1440S	●			
14.5	TEZ1450S	●			
14.6	TEZ1460S	●	11.5	4.8	TEZD15*
14.7	TEZ1470S	●			
14.8	TEZ1480S	●			
14.9	TEZ1490S	●			
15.0	TEZ1500S	●			
15.1	TEZ1510S	●			
15.2	TEZ1520S	●			
15.3	TEZ1530S	●			
15.4	TEZ1540S	●			
15.5	TEZ1550S	●			
15.6	TEZ1560S	●	12.4	5.0	TEZD16*
15.7	TEZ1570S	●			
15.8	TEZ1580S	●			
15.9	TEZ1590S	●			
16.0	TEZ1600S	●			
16.1	TEZ1610S	●			
16.2	TEZ1620S	●			
16.3	TEZ1630S	●			
16.4	TEZ1640S	●			
16.5	TEZ1650S	●			
16.6	TEZ1660S	●	13.2	5.5	TEZD17*
16.7	TEZ1670S	●			
16.8	TEZ1680S	●			
16.9	TEZ1690S	●			
17.0	TEZ1700S	●			
17.1	TEZ1710S	●			
17.2	TEZ1720S	●			
17.3	TEZ1730S	●			
17.4	TEZ1740S	●			
17.5	TEZ1750S	●			
17.6	TEZ1760S	●	13.5	5.8	TEZD18*
17.7	TEZ1770S	●			
17.8	TEZ1780S	●			
17.9	TEZ1790S	●			
18.0	TEZ1800S	●			
18.1	TEZ1810S	●			

Dc	Cat.No.	Stk	A	T	Holder
18.2	TEZ1820S	●	13.5	5.8	TEZD18*
18.3	TEZ1830S	●			
18.4	TEZ1840S	●			
18.5	TEZ1850S	●			
18.6	TEZ1860S	●	14.2	6.0	TEZD19*
18.7	TEZ1870S	●			
18.8	TEZ1880S	●			
18.9	TEZ1890S	●			
19.0	TEZ1900S	●			
19.1	TEZ1910S	●			
19.2	TEZ1920S	●			
19.3	TEZ1930S	●			
19.4	TEZ1940S	●			
19.5	TEZ1950S	●			
19.6	TEZ1960S	●	15.1	6.5	TEZD20*
19.7	TEZ1970S	●			
19.8	TEZ1980S	●			
19.9	TEZ1990S	●			
20.0	TEZ2000S	●			

Screw	Torque (N·m)
DSW-2045H	0.9
TSW-2556H	1.2
TSW-2567H	1.2
DSW-307H	2.1
DSW-309H	2.1
TSW-3510H	3.0
TSW-3512H	3.0

INDEXABLE DRILL

TEZD Type

■ Recommended Cutting Conditions

● TEZ type JC8050

Material	Structural Steel , Carbon Steel below 280HB	Alloy Steel 280-350HB	Tool Steel below 255HB
Vc (m/min)	75 - 90	70 - 90	70 - 90
f (mm/rev)	0.30 - 0.35	0.22 - 0.25	0.22 - 0.25

Material	Stainless Steel	Grey Cast Iron	Nodular Cast Iron
Vc (m/min)	45	85 - 110	60 - 90
f (mm/rev)	0.25	0.30 - 0.40	0.15 - 0.28

● TEZ-S type JC7515

Material	Titanium Alloy	Stainless Steel
Vc (m/min)	35 - 60	45 - 80
f (mm/rev)	0.15 - 0.20	0.15 - 0.20

Note

1. Use water-soluble coolant.
2. Adjust cutting conditions according to machine rigidity or work rigidity.
3. When using -XL (8D) type , reduce rpm & Vf by 20% from standard cutting conditions.
Pre-drilling of guide-hole (depth : 0.5D) is recommended.

SOLID CARBIDE ENDMILLS

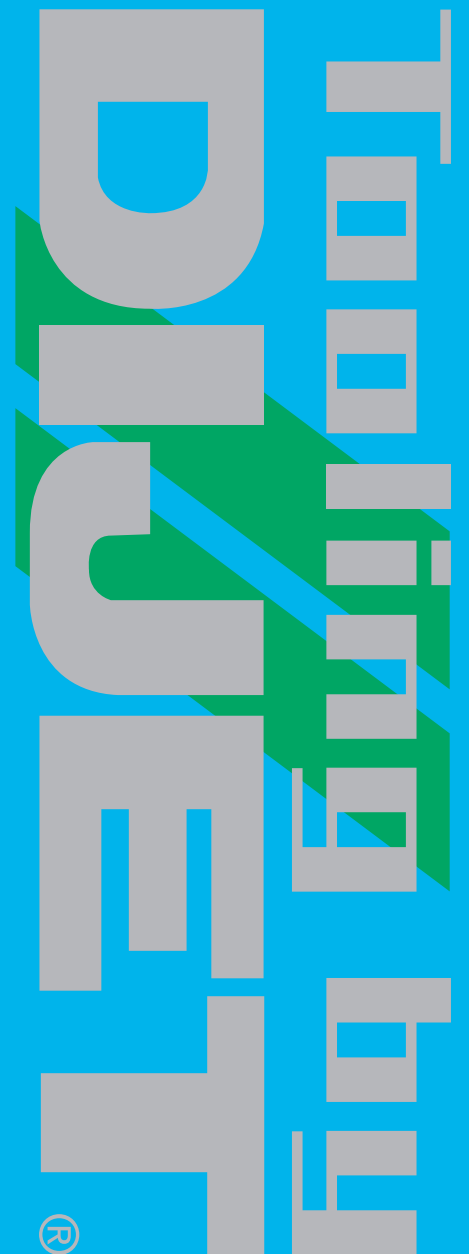

ONE-CUT 70

SEH Type

One-Cut 70

UP TO 70HRC

Feature 1

High Speed & High Efficiency Machining on High Hardened Materials.

Feature 2

High Precision Machining from Semi-finishing to Finishing.

Feature 3

Outstanding tool life with combination of newly developed DH coating & Super-micro grain carbide

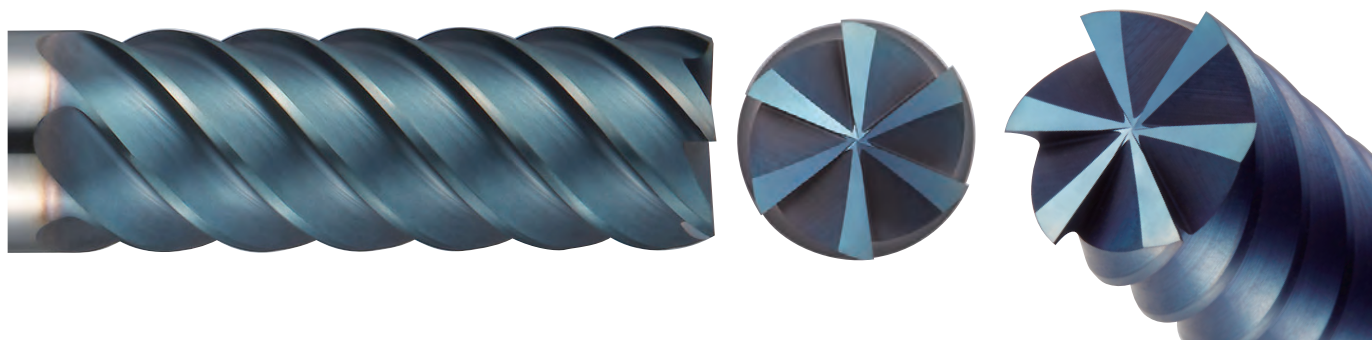

DH COATING

● Properties of DIJET PVD coating

	DH coating	DV coating	DZ coating (TiAlN)
Hardness (Hv)	3,500~3,700	3,300~3,500	2,800~2,900
Oxidation temperature (°C)	1,100~1,200	1,000~1,100	700~800
Coefficient of friction	0.5	0.65	0.6

- Greatly improved for higher hardness and heat resistance.
- Super multi layer coating that has high thermal shock resistance suppress sudden chipping.
- Achieves excellent tool life from semi-finishing to finishing.

Layer with high hardness & heat resistance
 Layer with high adhesion & fracture resistance
 Super micro-grain carbide

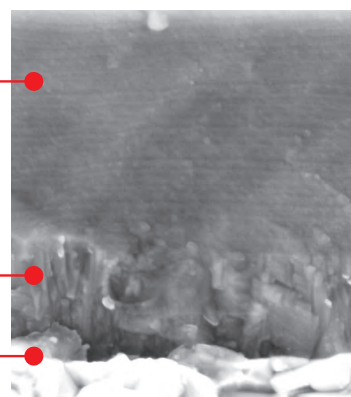

ONE-CUT 70

SEH Type

SEH
TYPE

For High hardened materials up to 70HRC

● Helix angle 50°

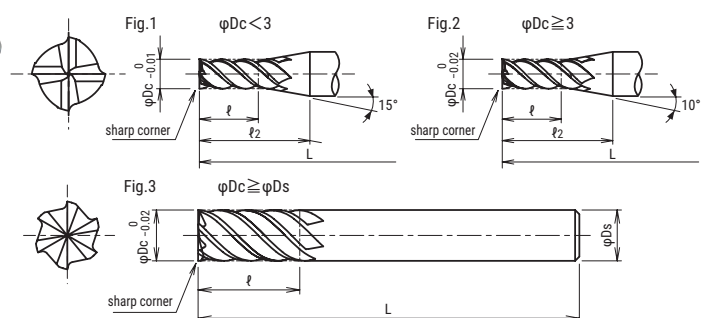
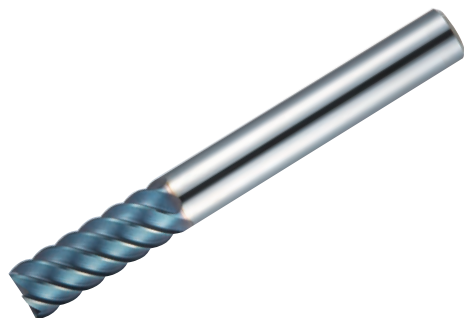

Type	Cat.No.	Stock	No.of Flutes	Dimensions (mm)					Fig.	
				φDc	ℓ	ℓ_2	L	φDs		
Short	SEHS4010	●	4	1	2	12	60	6	1	
	SEHS4020	●		2	4					
	SEHS4030	●		3	7	17			2	
	SEHS4040	●	4	9	16					
	SEHS4050	●	5	12		3				
	SEHS6060	●	6	6	13				—	
Regular	SEHH4010	●	4	1	3.5	13	60	6	1	
	SEHH4015	●		1.5	5					14
	SEHH4020	●		2	7					15
	SEHH4025	●		2.5	8					
	SEHH4030	●		3	10	20			2	
	SEHH4035	●		3.5	12					
	SEHH4040	●		4		19				
	SEHH4045	●		4.5		20				
	SEHH4050	●		5	19					
	SEHH4055	●		5.5	18					
	SEHH6060	●		6	6	—			3	
	SEHH6065	●		6.5	20	25				
	SEHH6070	●	7	24						
	SEHH6075	●	7.5	22		75	8	2		
	SEHH6080	●	8	—						
	SEHH6085	●	8.5	30	80			10	2	
	SEHH6090	●	9	29						
	SEHH6095	●	9.5	27						
	SEHH6100	●	10	—	3					
	SEHH6105	●	10.5	30		35	100	12	2	
	SEHH6110	●	11			34				
	SEHH6120	●	12		—	3				
	SEHH6130	●	13	35	45		105	16	2	
	SEHH6140	●	14		42					
SEHH6150	●	15	44		110	20			3	
SEHH6160	●	16	—							
SEHH6180	●	18	47	120			2			
SEHH6200	●	20	45		—	125		3		

ONE-CUT 70 **SEH Type**

SEH-R
TYPE

For High hardened materials up to 70HRC

- Helix angle 50°
- Corner radius R0.2

Semi-finishing

Finishing

Corner radius

DH Coating

Shoulder Milling

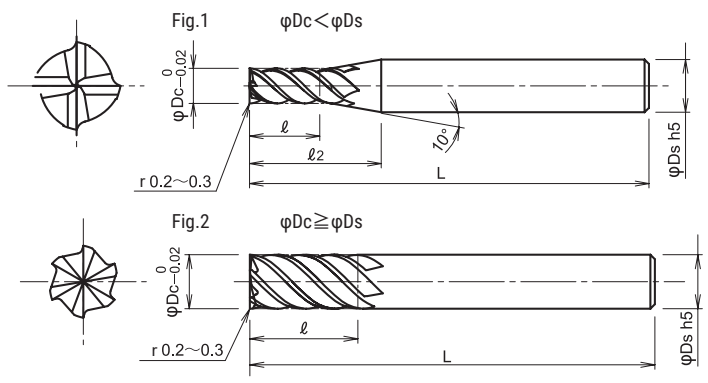
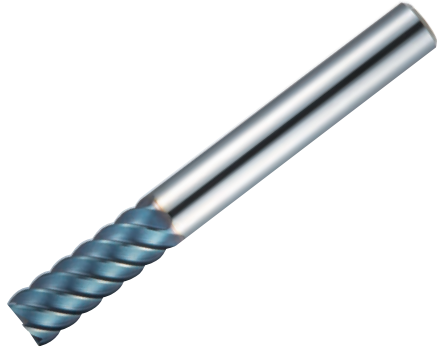

Cat.No.	Stock	No.of Flutes	Dimensions (mm)					Fig.			
			ϕDc	l	l_2	L	ϕDs				
SEHH4030-R02	●	4	3	10	20	60	6	1			
SEHH4040-R02	●		4	12	19						
SEHH4050-R02	●		5	15	-						
SEHH6060-R02	●	6	6	20	24	75	8	2			
SEHH6070-R02	●		7		29			1			
SEHH6080-R02	●		8		-			2			
SEHH6090-R02	●		9	25	29	80	10	1			
SEHH6100-R02	●		10	30	-	100	12	2			
SEHH6120-R02	●		12								
SEHH6160-R02	●		16						40	110	16
SEHH6200-R02	●		20						45	125	20

ONE-CUT 70

SEH Type

SEH-R
TYPE

For High hardened materials up to 70HRC

- Helix angle 50°
- Corner radius type

Semi-finishing

Finishing

Corner radius

DH
Coating

Shoulder Milling

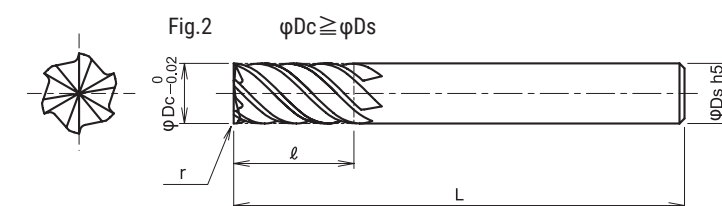
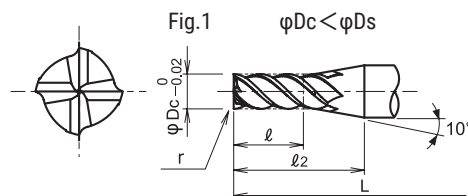

Cat.No.	Stock	No. of Flutes	Dimensions (mm)						Fig.
			r	ϕDc	ℓ	$\ell 2$	L	ϕDs	
SEHH4030-R03	●	4	0.3	3	10	20	60	6	1
SEHH4030-R05	●		0.5						
SEHH4040-R03	●		0.3	4	12	19			
SEHH4040-R05	●		0.5						
SEHH4050-R03	●		0.3	5	15	19			
SEHH4050-R05	●		0.5						
SEHH6060-R03	●	6	0.3	6	20	75	8		
SEHH6060-R05	●		0.5						
SEHH6060-R10	●		1						
SEHH6080-R03	●		0.3	8	25	80	10		
SEHH6080-R05	●		0.5						
SEHH6080-R10	●		1						
SEHH6100-R03	●	6	0.3	10	30	100	12	2	
SEHH6100-R05	●		0.5						
SEHH6100-R10	●		1						
SEHH6100-R15	●		1.5						
SEHH6120-R03	●		0.3	12	40	110	16		
SEHH6120-R05	●		0.5						
SEHH6120-R10	●	1							
SEHH6120-R15	●	1.5							
SEHH6160-R03	●	6	0.3	16	45	125	20		
SEHH6160-R05	●		0.5						
SEHH6160-R10	●		1						
SEHH6160-R15	●		1.5						
SEHH6200-R03	●		6	0.3	20	45	125	20	
SEHH6200-R05	●			0.5					
SEHH6200-R10	●	1							
SEHH6200-R15	●	1.5							

ONE-CUT 70 **SEH Type**

SEHM
TYPE

For High hardened materials up to 70HRC

- Helix angle 50°
- Medium length of cut

Semi-finishing

Finishing

Gash land

DH
Coating

Shoulder Milling

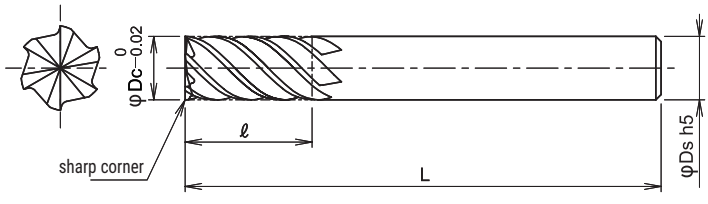
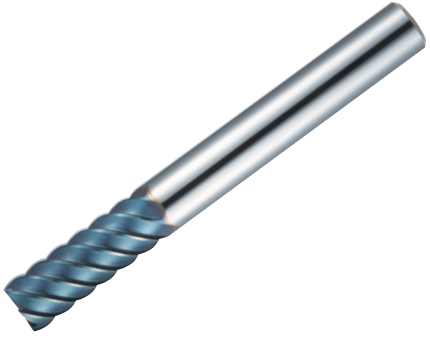

Type	Cat.No.	Stock	No. of Flutes	Dimensions (mm)			
				φDc	ℓ	L	φDs
Medium	SEHM6060	●	6	6	20	65	6
	SEHM6080	●		8	28	80	8
	SEHM6100	●		10	35	90	10
	SEHM6120	●		12	45	110	12
	SEHM6160	●		16	55	120	16
	SEHM6200	●		20	60	140	20

ONE-CUT 70

SEH Type



SEHL
TYPE

For High hardened materials up to 70HRC

- Helix angle 50°
- Long length of cut

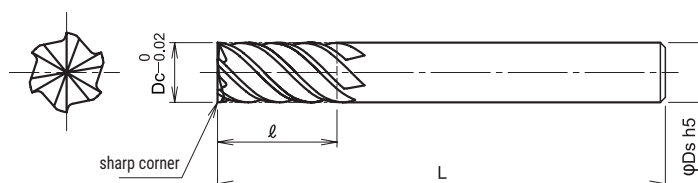
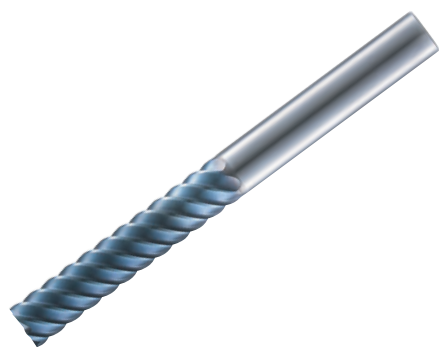

Type	Cat.No.	Stock	No.of Flutes	Dimensions (mm)			
				φDc	l	L	φDs
Long	SEHL6060	●	6	6	26	70	6
	SEHL6080	●		8	36	90	8
	SEHL6100	●		10	46	100	10
	SEHL6120	●		12	56	120	12
	SEHL6160	●		16	66	135	16
	SEHL6200	●		20	76	155	20

ONE-CUT 70

SEH Type

■ SEHS / SEHH / SEHH-R02 / SEHH-R type Recommended cutting conditions

● SIDE CUTTING

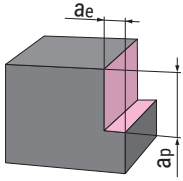
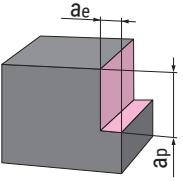
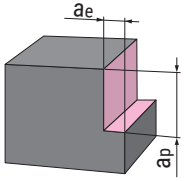
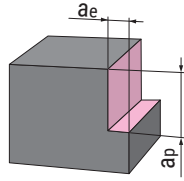
Material	Mold steel (NAK80, HPM1, P21) 38~43HRC		Hardened steel (SKD61, DAC, DHA) 42~52HRC		Hardened steel (SKD11, SLD, DC11) 55~62HRC		HSS (SKH, HAP) 63~70HRC	
Type of machining	 $a_p \leq 1.5D_c$ $a_e \leq 0.05D_c$		 $a_p \leq 1.5D_c$ $a_e \leq 0.04D_c$		 $a_p \leq 1.5D_c$ $a_e \leq 0.04D_c$ (MAX. 0.6mm)		 $a_p \leq 1.5D_c$ $a_e \leq 0.02D_c$ (MAX. 0.4mm)	
ϕD_c (mm)	n (min ⁻¹)	Vf (mm/min)	n (min ⁻¹)	Vf (mm/min)	n (min ⁻¹)	Vf (mm/min)	n (min ⁻¹)	Vf (mm/min)
1	40,000	700	25,000	410	20,000	320	10,000	130
2	24,000	950	15,000	560	12,000	430	6,400	220
3	24,000	1,300	15,000	800	12,000	600	6,000	250
4	18,000	1,800	12,000	1,100	9,500	800	5,100	300
6	12,000	2,200	8,000	1,400	6,500	1,100	3,500	420
8	10,000	2,200	6,000	1,400	5,000	1,100	2,500	420
10	8,000	2,200	5,000	1,400	4,000	1,100	2,000	420
12	6,500	1,900	4,000	1,200	3,300	900	1,700	350
16	5,000	1,480	3,000	930	2,500	700	1,300	260
20	3,800	1,150	2,300	730	2,000	550	1,000	200

Note

1. These cutting conditions are for general guidance.
2. The figures should be adjusted according to machining shape, purpose and rigidity of machine and work clamping.
3. Recommend to down cut with air blow or mist coolant.

ONE-CUT 70

SEH Type

■ SEHM type Recommended cutting conditions

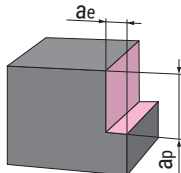
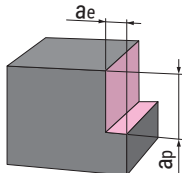
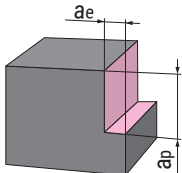
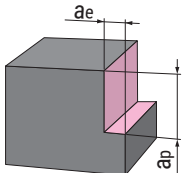
Material	Mold steel (NAK80, HPM1, P21) 38~43HRC		Hardened steel (SKD61, DAC, DHA) 42~52HRC		Hardened steel (SKD11, SLD, DC11) 55~62HRC		HSS (SKH, HAP) 63~70HRC	
Type of machining	 $ap \leq 2.25Dc$ $ae \leq 0.03Dc$		 $ap \leq 2.25Dc$ $ae \leq 0.025Dc$		 $ap \leq 2.25Dc$ $ae \leq 0.025Dc$		 $ap \leq 2.25Dc$ $ae \leq 0.01Dc$	
ϕDc (mm)	n (min ⁻¹)	Vf (mm/min)	n (min ⁻¹)	Vf (mm/min)	n (min ⁻¹)	Vf (mm/min)	n (min ⁻¹)	Vf (mm/min)
6	10,600	1,900	6,400	1,200	5,300	1,000	2,700	320
8	8,000	1,900	4,800	1,200	4,000	1,000	2,000	360
10	6,400	1,900	3,800	1,200	3,200	1,000	1,600	380
12	5,300	1,600	3,200	1,000	2,700	800	1,300	240
16	4,000	1,200	2,400	700	2,000	600	1,000	180
20	3,200	1,000	1,900	600	1,600	500	800	140

Note

1. These cutting conditions are for general guidance.
2. The figures should be adjusted according to machining shape, purpose and rigidity of machine and work clamping.
3. Recommend to down cut with air blow or mist coolant.

ONE-CUT 70

SEH Type

■ SEHL type Recommended cutting conditions

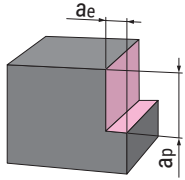
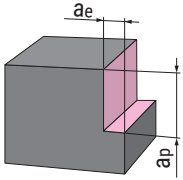
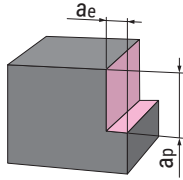
Material	Mold steel (NAK80, HPM1, P21) 38~43HRC		Hardened steel (SKD61, DAC, DHA) 42~52HRC		Hardened steel (SKD11, SLD, DC11) 55~62HRC	
Type of machining	 $a_p \leq 3D_c$ $a_e \leq 0.01D_c$		 $a_p \leq 3D_c$ $a_e \leq 0.01D_c$		 $a_p \leq 3D_c$ $a_e \leq 0.01D_c$	
ϕD_c (mm)	n (min ⁻¹)	V_f (mm/min)	n (min ⁻¹)	V_f (mm/min)	n (min ⁻¹)	V_f (mm/min)
6	3,180	760	2,650	480	2,100	380
8	2,390	720	1,990	480	1,590	380
10	1,910	690	1,590	480	1,270	380
12	1,590	670	1,330	480	1,060	380
16	1,190	570	1,000	420	800	340
20	950	510	800	380	640	310

Note

1. These cutting conditions are for general guidance.
2. The figures should be adjusted according to machining shape, purpose and rigidity of machine and work clamping.
3. Recommend to down cut with air blow or mist coolant.

HARD 1 RADIUS

SFSR Type

HARD 1 RADIUS

Feature 1

Highly Rigid Design for High Efficiency Machining

Feature 2

Suppress Vibration with Variable Helix Angle & Unequal Spacing Teeth Geometry

Feature 3

Special design on center of cutting edge improves cutting performance

Feature 4

Applicable for High Spindle Machine & Shrink Fit Holder
Shank diameter tolerance: h5

Feature 5

Excellent tool life for Hardened Materials with Newly developed grade "DH110"



New PVD coating <DH coating>

● Properties of DIJET PVD coating

	DH coating	DV coating	DZ coating(TiAlN)
Hardness(Hv)	3,500~3,700	3,300~3,500	2,800~2,900
Oxidation temperature (°C)	1,100~1,200	1,000~1,100	700~800
Coefficient of friction	0.5	0.65	0.6

HARD 1 RADIUS

SFSR Type

SFSR
TYPE

For General steel to Hardened steel

● Helix angle 50°-52°



Roughing

Semi-finishing

Finishing



Fig.1

$$\varphi D_c < \varphi D_s$$

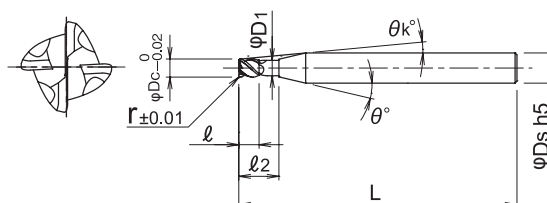
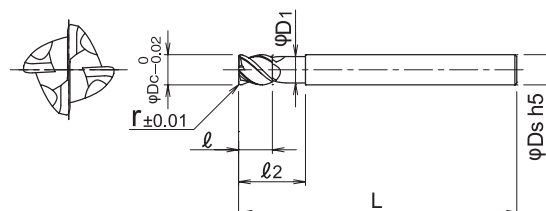

Fig.2

$$\varphi D_c = \varphi D_s$$



Cat.No.	Stock	Dimensions (mm)									Fig.	
		r	φD_c	l	l_2	L	φD_1	θ	θ_k	φD_s		
SFSR4020S04-R05	●	0.5	2	2	4	40	1.9	20°	9.1°	4	1	
SFSR4020S06-R05	●								12.6°	6		
SFSR4030S04-R08	●								4.4°	4		
SFSR4030S06-R08	●	0.8	3	3	6		2.9	9.2°	6			
SFSR4040S04-R10	●	1	4	4	8		3.8	—	—	4		2
SFSR4040S06-R10	●							20°	5.9°	6		1
SFSR4050S06-R12	●	1.2	5	5	10	4.8	2.9°					
SFSR4060S06-R10	●	1	6	6	12	5.8	—	—	8	2		
SFSR4060S06-R15	●	1.5										
SFSR4080S08-R10	●	1	8	8	16	7.8	—	—	10			
SFSR4080S08-R20	●	2										
SFSR4100S10-R20	●	3	10	10	20	9.8	—	—	12			
SFSR4100S10-R30	●											
SFSR4120S12-R20	●	2	12	12	24	11.8	—	—				
SFSR4120S12-R30	●	3										

HARD 1 RADIUS

SFSR Type

SFSR
TYPE

For General steel to Hardened steel

- Helix angle 50°-52°
- Corner radius accuracy : ± 0.005

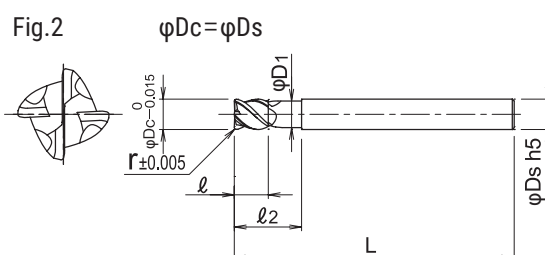
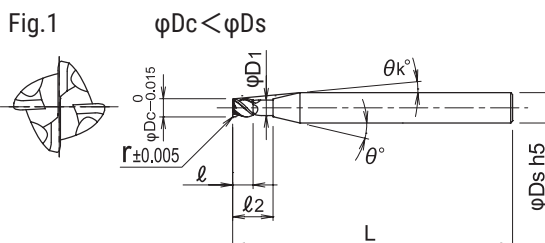

Cat.No.	Stock	Dimensions (mm)									Fig.
		r	φD_c	l	l_2	L	φD_1	θ	θ_k	φD_s	
SFSR4020S06-R05-06	●	0.5	2	2	6	60	1.9	20°	10.27°	6	1
SFSR4030S06-R08-09	●	0.8	3	3	9		2.9		6.91°		
SFSR4040S06-R10-12	●	1	4	4	12		3.8		4.15°		
SFSR4050S06-R12-15	●	1.2	5	5	15		4.7		1.88°		
SFSR4060S06-R05-18	●	0.5	6	6	18	90	5.7			6	
SFSR4060S06-R05-30	●				30						
SFSR4060S06-R10-18	●	1	6	6	18	90	5.7			6	
SFSR4060S06-R10-30	●				30						
SFSR4060S06-R15-18	●	1.5	6	6	18	90	5.7			6	
SFSR4060S06-R15-30	●				30						
SFSR4080S08-R05-24	●	0.5	8	8	24	75	7.6			8	
SFSR4080S08-R05-40	●				40						
SFSR4080S08-R10-24	●	1	8	8	24	100	7.6			8	
SFSR4080S08-R10-40	●				40						
SFSR4080S08-R20-24	●	2	8	8	24	100	7.6			8	
SFSR4080S08-R20-40	●				40						
SFSR4100S10-R05-30	●	0.5	10	10	30	80	9.5			10	2
SFSR4100S10-R05-50	●				50						
SFSR4100S10-R10-30	●	1	10	10	30	110	9.5			10	2
SFSR4100S10-R10-50	●				50						
SFSR4100S10-R20-30	●	2	10	10	30	110	9.5			10	2
SFSR4100S10-R20-50	●				50						
SFSR4100S10-R30-30	●	3	10	10	30	110	9.5			10	2
SFSR4100S10-R30-50	●				50						
SFSR4120S12-R05-36	●	0.5	12	12	36	100	11.5			12	
SFSR4120S12-R05-60	●				60						
SFSR4120S12-R10-36	●	1	12	12	36	120	11.5			12	
SFSR4120S12-R10-60	●				60						
SFSR4120S12-R20-36	●	2	12	12	36	120	11.5			12	
SFSR4120S12-R20-60	●				60						
SFSR4120S12-R30-36	●	3	12	12	36	120	11.5			12	
SFSR4120S12-R30-60	●				60						

HARD 1 RADIUS

SFSR Type

SFSR
TYPE

For General steel to Hardened steel

- Helix angle 50°-52°
- Corner radius R0.2

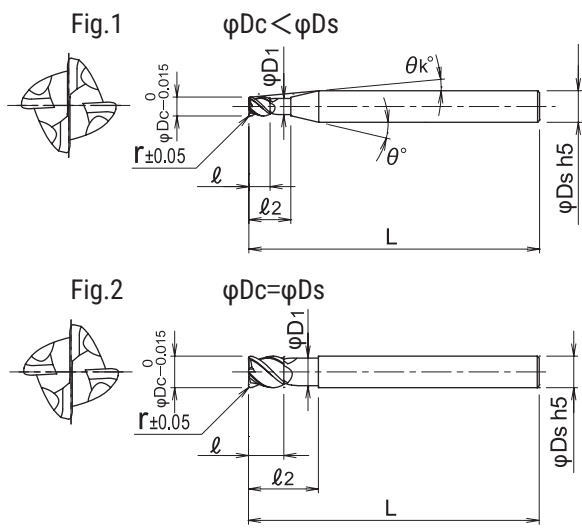

Cat.No.	Stock	Dimensions (mm)									Fig.
		r	φ_{Dc}	ℓ	$\ell 2$	L	φ_{D1}	θ	θk	φ_{Ds}	
SFSR4020S06-R02-06	●	0.2	2	2	6	60	1.9	20°	10.03°	6	1
SFSR4030S06-R02-09	●		3	3	9		2.9		6.62°		
SFSR4040S06-R02-12	●		4	4	12		3.8		3.93°		
SFSR4050S06-R02-15	●		5	5	15		4.7		1.77°		
SFSR4060S06-R02-18	●		6	6	18	5.7	-	-	8	2	
SFSR4080S08-R02-24	●		8	8	24	7.6			10		
SFSR4100S10-R02-30	●		10	10	30	9.5			12		
SFSR4120S12-R02-36	●		12	12	36	100	11.5				

HARD 1 RADIUS

SFSR Type

■ SFSR type Recommended cutting conditions

● Face milling - Roughing

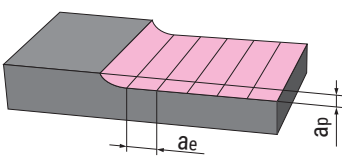
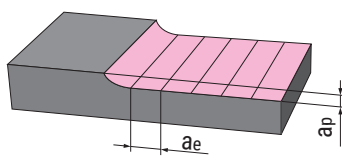
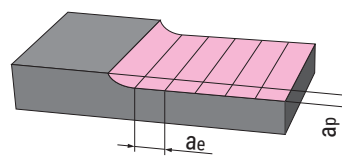
Material	Carbon steel (S50C, S55C) below 250HB		Alloy steel, Tool steel, Mold steel (SKD, SKH, NAK) below 45HRC		Stainless steel (SUS304)	
Type of machining	 $a_p \leq 0.3\text{mm}$ ($\phi D_c 2 - 0.15\text{mm}$) $a_e \leq 0.33D_c$		 $a_p \leq 0.3\text{mm}$ ($\phi D_c 2 - 0.15\text{mm}$) $a_e \leq 0.33D_c$		 $a_p \leq 0.15\text{mm}$ $a_e \leq 0.33D_c$	
ϕD_c (mm)	n (min ⁻¹)	V_f (mm/min)	n (min ⁻¹)	V_f (mm/min)	n (min ⁻¹)	V_f (mm/min)
2	24,000	7,000	24,000	7,000	25,000	2,500
3	17,000	7,000	17,000	7,000	17,000	3,000
4	13,000	8,000	13,000	8,000	13,000	3,500
5	10,000	9,000	10,000	9,000	10,500	4,000
6	8,500	10,000	8,500	10,000	8,600	4,200
8	6,500	10,000	6,500	10,000	6,500	4,200
10	5,200	10,000	5,200	10,000	4,500	4,200
12	4,300	10,000	4,300	10,000	3,000	4,200

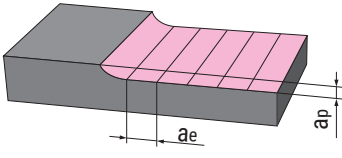
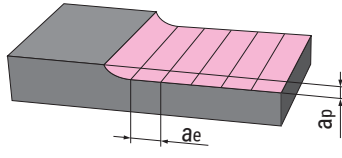
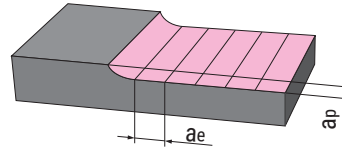
Material	Hardened steel (SKD61, DAC, DHA) 42~52HRC		Hardened steel (SKD11, SKH51, SLD) 55~62HRC		Hardened steel (SKH, HAP) 63~70HRC	
Type of machining	 $a_p \leq 0.15\text{mm}$ $a_e \leq 0.33D_c$		 $a_p \leq 0.15\text{mm}$ $a_e \leq 0.33D_c$		 $a_p \leq 0.15\text{mm}$ $a_e \leq 0.33D_c$	
ϕD_c (mm)	n (min ⁻¹)	V_f (mm/min)	n (min ⁻¹)	V_f (mm/min)	n (min ⁻¹)	V_f (mm/min)
2	16,000	2,300	9,000	1,700	3,000	600
3	12,500	3,000	7,300	1,900	3,000	750
4	11,000	3,500	6,500	2,100	3,000	1,000
5	9,500	4,800	6,200	2,300	3,000	1,200
6	8,000	5,500	6,000	2,500	3,200	1,400
8	6,000	6,000	4,300	2,300	2,500	1,500
10	4,800	6,000	3,300	2,500	2,000	1,600
12	4,000	7,500	2,500	2,500	1,500	1,700

Note

1. These cutting conditions are for general guidance.
2. The figures should be adjusted according to machining shape, purpose and rigidity of machine and work clamping.
3. If rpm available is lower than that recommended, reduce the feed rate proportionately.
4. Recommend to down cut with air blow or mist coolant.
5. Wet cutting is recommended for stainless steel.

HARD 1 RADIUS

SFSR Type

■ SFSR type Recommended cutting conditions

● Face milling - Finishing

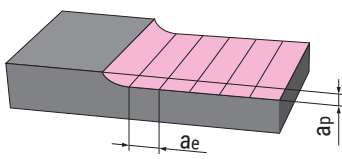
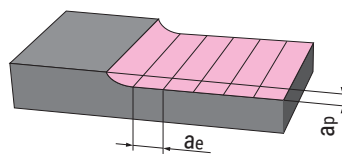
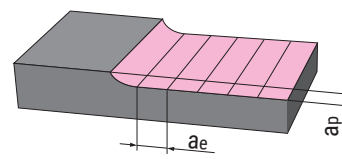
Material	Carbon steel (S50C, S55C) below 250HB		Alloy steel, Tool steel, Mold steel (SKD, SKH, NAK) below 45HRC		Stainless steel (SUS304)	
Type of machining	 $a_p \leq 0.15\text{mm}$ $a_e \leq 0.1D_c$		 $a_p \leq 0.15\text{mm}$ $a_e \leq 0.1D_c$		 $a_p \leq 0.15\text{mm}$ $a_e \leq 0.1D_c$	
ϕD_c (mm)	n (min ⁻¹)	V_f (mm/min)	n (min ⁻¹)	V_f (mm/min)	n (min ⁻¹)	V_f (mm/min)
2	30,000	2,000	30,000	2,000	30,000	2,000
3	20,000	2,000	20,000	2,000	20,000	2,000
4	15,000	2,000	15,000	2,000	15,000	2,000
5	12,000	2,000	12,000	2,000	12,000	2,000
6	10,000	2,000	10,000	2,000	10,000	2,000
8	7,500	2,000	7,500	2,000	7,500	2,000
10	6,000	1,900	6,000	1,900	5,000	1,500
12	5,000	1,800	5,000	1,800	3,000	1,000

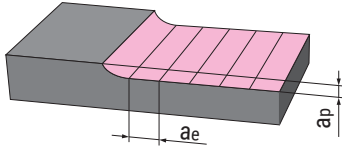
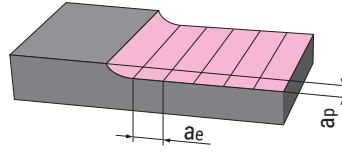
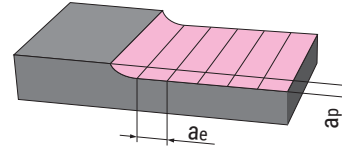
Material	Hardened steel (SKD61, DAC, DHA) 42~52HRC		Hardened steel (SKD11, SKH51, SLD) 55~62HRC		Hardened steel (SKH, HAP) 63~70HRC	
Type of machining	 $a_p \leq 0.1\text{mm}$ $a_e \leq 0.1D_c$		 $a_p \leq 0.1\text{mm}$ $a_e \leq 0.1D_c$		 $a_p \leq 0.05\text{mm}$ $a_e \leq 0.1D_c$	
ϕD_c (mm)	n (min ⁻¹)	V_f (mm/min)	n (min ⁻¹)	V_f (mm/min)	n (min ⁻¹)	V_f (mm/min)
2	20,000	1,300	13,000	900	9,000	400
3	14,000	1,100	9,000	700	6,000	350
4	11,000	950	7,000	550	4,700	300
5	9,500	900	5,700	550	3,800	300
6	8,000	800	4,700	450	3,200	250
8	6,000	700	3,500	400	2,500	250
10	5,000	650	2,800	350	2,000	200
12	4,000	650	2,400	350	1,600	200

Note

1. These cutting conditions are for general guidance.
2. The figures should be adjusted according to machining shape, purpose and rigidity of machine and work clamping.
3. If rpm available is lower than that recommended, reduce the feed rate proportionately.
4. Recommend to down cut with air blow or mist coolant.
5. Wet cutting is recommended for stainless steel.

HARD 1 RADIUS

SFSR Type

■ SFSR type Recommended cutting conditions

● Side milling - Roughing

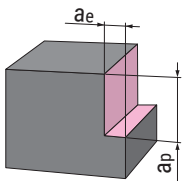
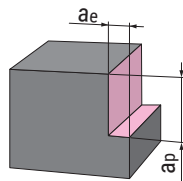
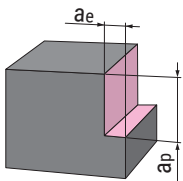
Material	Carbon steel (S50C, S55C) below 250HB		Alloy steel, Tool steel, Mold steel (SKD, SKH, NAK) below 45HRC		Stainless steel (SUS304)	
Type of machining	 $a_p \leq 0.6D_c$ $a_e \leq 0.08D_c$		 $a_p \leq 0.6D_c$ $a_e \leq 0.08D_c$		 $a_p \leq 0.6D_c$ $a_e \leq 0.04D_c$	
ϕD_c (mm)	n (min ⁻¹)	V_f (mm/min)	n (min ⁻¹)	V_f (mm/min)	n (min ⁻¹)	V_f (mm/min)
2	24,000	950	24,000	950	3,200	2,500
3	24,000	1,300	24,000	1,300	2,700	2,200
4	18,000	1,800	18,000	1,800	2,300	2,000
5	15,000	2,000	15,000	2,000	2,000	1,900
6	12,000	2,200	12,000	2,200	1,800	1,800
8	10,000	2,200	10,000	2,200	1,300	1,300
10	8,000	2,200	8,000	2,200	1,000	1,000
12	6,500	1,900	6,500	1,900	800	800

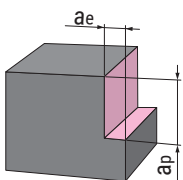
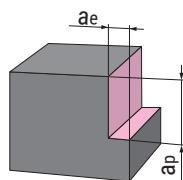
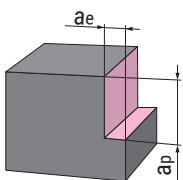
Material	Hardened steel (SKD61, DAC, DHA) 42~52HRC		Hardened steel (SKD11, SKH51, SLD) 55~62HRC		Hardened steel (SKH, HAP) 63~70HRC	
Type of machining	 $a_p \leq 0.6D_c$ $a_e \leq 0.08D_c$		 $a_p \leq 0.6D_c$ $a_e \leq 0.08D_c$		 $a_p \leq 0.6D_c$ $a_e \leq 0.08D_c$	
ϕD_c (mm)	n (min ⁻¹)	V_f (mm/min)	n (min ⁻¹)	V_f (mm/min)	n (min ⁻¹)	V_f (mm/min)
2	13,000	1,000	12,000	1,000	6,400	600
3	13,000	1,300	11,000	1,200	6,000	600
4	11,000	1,500	9,000	1,200	5,100	550
5	9,000	1,600	7,200	1,200	4,200	550
6	7,500	1,800	6,000	1,200	3,500	650
8	5,500	2,200	4,500	1,200	2,500	650
10	4,500	2,500	3,600	1,400	2,000	600
12	3,800	3,000	3,000	1,400	1,700	600

Note

1. These cutting conditions are for general guidance.
2. The figures should be adjusted according to machining shape, purpose and rigidity of machine and work clamping.
3. If rpm available is lower than that recommended, reduce the feed rate proportionately.
4. Recommend to down cut with air blow or mist coolant.
5. Wet cutting is recommended for stainless steel.

HARD 1 RADIUS

SFSR Type

■ SFSR type Recommended cutting conditions

● Side milling - Finishing

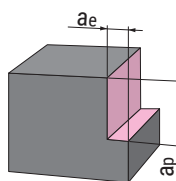
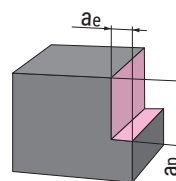
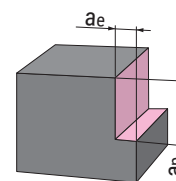
Material	Carbon steel (S50C, S55C) below 250HB		Alloy steel, Tool steel, Mold steel (SKD, SKH, NAK) below 45HRC		Stainless steel (SUS304)	
Type of machining	 $a_p \leq 0.3\text{mm}$ $a_e \leq 0.1\text{mm}$		 $a_p \leq 0.3\text{mm}$ $a_e \leq 0.1\text{mm}$		 $a_p \leq 0.3\text{mm}$ $a_e \leq 0.1\text{mm}$	
ϕDc (mm)	n (min ⁻¹)	V_f (mm/min)	n (min ⁻¹)	V_f (mm/min)	n (min ⁻¹)	V_f (mm/min)
2	40,000	4,500	40,000	4,500	40,000	7,500
3	29,000	4,000	29,000	4,000	28,000	5,500
4	22,000	4,000	22,000	4,000	21,000	4,500
5	18,000	4,000	18,000	4,000	17,000	4,000
6	15,000	3,700	15,000	3,700	14,000	3,500
8	11,000	2,800	11,000	2,800	11,000	3,000
10	8,900	2,600	8,900	2,600	9,000	2,600
12	7,400	2,300	7,400	2,300	7,500	2,200

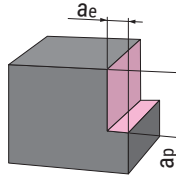
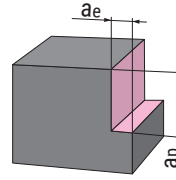
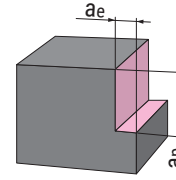
Material	Hardened steel (SKD61, DAC, DHA) 42~52HRC		Hardened steel (SKD11, SKH51, SLD) 55~62HRC		Hardened steel (SKH, HAP) 63~70HRC	
Type of machining	 $a_p \leq 0.3\text{mm}$ $a_e \leq 0.1\text{mm}$		 $a_p \leq 0.2\text{mm}$ $a_e \leq 0.1\text{mm}$		 $a_p \leq 0.1\text{mm}$ $a_e \leq 0.1\text{mm}$	
ϕDc (mm)	n (min ⁻¹)	V_f (mm/min)	n (min ⁻¹)	V_f (mm/min)	n (min ⁻¹)	V_f (mm/min)
2	40,000	2,500	30,000	2,000	23,000	550
3	26,500	2,000	20,000	1,500	15,000	450
4	20,000	1,800	15,000	1,200	12,000	400
5	16,000	1,500	12,000	1,100	9,500	380
6	13,500	1,300	10,000	900	8,000	350
8	10,000	1,000	7,500	700	6,000	280
10	8,000	800	6,000	600	5,000	280
12	6,500	700	5,000	500	4,000	280

Note

1. These cutting conditions are for general guidance.
2. The figures should be adjusted according to machining shape, purpose and rigidity of machine and work clamping.
3. If rpm available is lower than that recommended, reduce the feed rate proportionately.
4. Recommend to down cut with air blow or mist coolant.
5. Wet cutting is recommended for stainless steel.

HARD 1 RADIUS

SFSR Type

■ SFSR type Recommended cutting conditions

● Slot milling

Material	Carbon steel (S50C, S55C) below 250HB		Alloy steel, Tool steel, Mold steel (SKD, SKH, NAK) below 45HRC		Stainless steel (SUS304)	
Type of machining	 $a_p \leq 0.3D_c$ $a_e = D_c$		 $a_p \leq 0.3D_c$ $a_e = D_c$		 $a_p \leq 0.25D_c$ $a_e = D_c$	
ϕD_c (mm)	n (min ⁻¹)	V_f (mm/min)	n (min ⁻¹)	V_f (mm/min)	n (min ⁻¹)	V_f (mm/min)
2	11,000	650	11,000	650	2,500	190
3	9,500	750	9,500	750	2,300	180
4	8,500	800	8,500	800	2,000	170
5	7,600	1,000	7,600	1,000	1,800	160
6	6,600	1,100	6,600	1,100	1,500	150
8	5,000	1,200	5,000	1,200	1,100	130
10	4,000	1,200	4,000	1,200	850	130
12	3,300	1,300	3,300	1,300	700	130

Material	Hardened steel (SKD61, DAC, DHA) 42~52HRC		Hardened steel (SKD11, SKH51, SLD) 55~62HRC		Hardened steel (SKH, HAP) 63~70HRC	
Type of machining	 $a_p \leq 0.3D_c$ $a_e = D_c$		 $a_p \leq 0.3D_c$ $a_e = D_c$		 $a_p \leq 0.3D_c$ $a_e = D_c$	
ϕD_c (mm)	n (min ⁻¹)	V_f (mm/min)	n (min ⁻¹)	V_f (mm/min)	n (min ⁻¹)	V_f (mm/min)
2	9,000	400	5,500	240	5,500	230
3	8,000	500	5,000	300	4,800	270
4	7,500	550	4,200	350	4,000	320
5	6,800	650	3,900	400	3,800	400
6	5,800	700	3,500	500	3,200	480
8	4,300	750	2,700	550	2,300	450
10	3,400	900	2,200	620	1,800	470
12	2,800	1,000	1,800	700	1,500	530

Note

1. These cutting conditions are for general guidance.
2. The figures should be adjusted according to machining shape, purpose and rigidity of machine and work clamping.
3. If rpm available is lower than that recommended, reduce the feed rate proportionately.
4. Recommend to down cut with air blow or mist coolant.
5. Wet cutting is recommended for stainless steel.
6. Recommended ramping angle is up to 45° for cutting general steel.
In case of Stainless steel & Hardened steel, recommended ramping angle is up to 5° only.

HARD 1 BALL

SFSB Type

HARD 1 BALL

Feature 1

Newly developed short length type solid carbide ball nose endmill that has high tool rigidity for stability and reliability.

Feature 2

Secure Radius Accuracy : $\pm 0.005\text{mm}$
For better surface finish,
improving chipping resistance during machining

Feature 3

Shank diameter tolerance : h5
Suitable for shrink fit holders

Feature 4

Excellent tool life for Hardened Materials with
Newly developed grade "DH110"

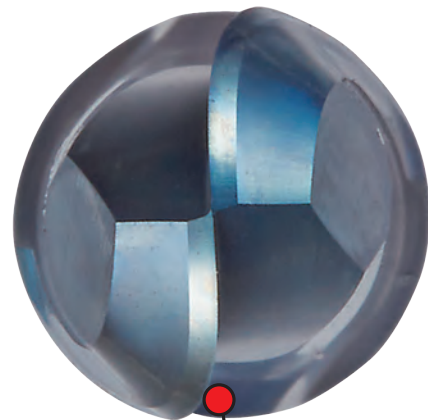

Radius Accuracy: $\pm 0.005\text{mm}$

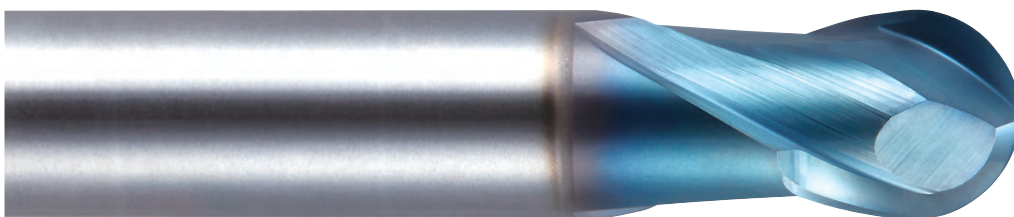
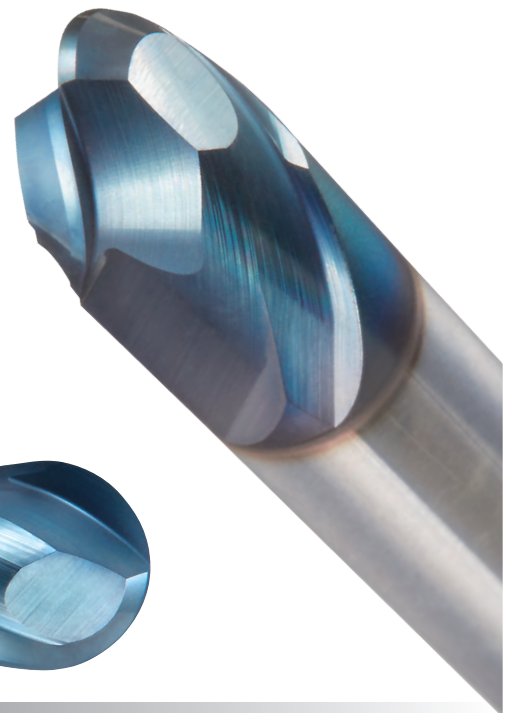

New PVD coating <DH coating>

● Properties of DIJET PVD coating

	DH coating	DV coating	DZ coating(TiAlN)
Hardness(Hv)	3,500~3,700	3,300~3,500	2,800~2,900
Oxidation temperature (°C)	1,100~1,200	1,000~1,100	700~800
Coefficient of friction	0.5	0.65	0.6

HARD 1 BALL **SFSB Type**

SFSB
TYPE

For General steel to Hardened steel

● Helix angle 30°

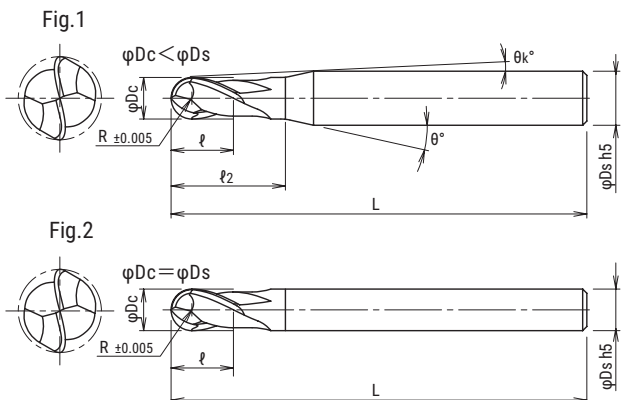
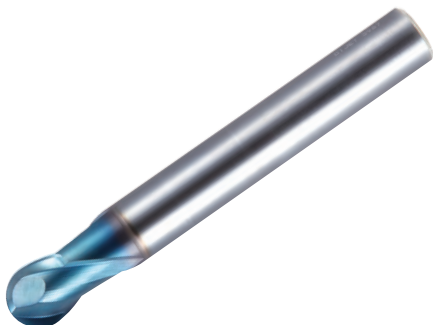

Cat.No.	Stock	Dimensions (mm)								Fig.
		R	ϕD_c	ℓ	ℓ_2	L	θ	θ_k	ϕD_s	
SFSB2010	●	0.5	1	1	1.5	40	12°	10.49°	4	1
SFSB2010-S6	●							11.04°	6	
SFSB2020	●	1	2	2	2.5		10°	7.86°	4	
SFSB2020-S6	●							8.8°	6	
SFSB2030	●	1.5	3	3	4			5.29°	4	
SFSB2030-S6	●							7.69°	6	
SFSB2040	●	2	4	4	—	—	4	2		
SFSB2040-S6	●				5	8°	5.59°	6	1	
SFSB2050	●	2.5	5	5	6	50	5°			2.79°
SFSB2060	●	3	6	6	—	60	—	—	8	2
SFSB2080	●	4	8	8					10	
SFSB2100	●	5	10	10					12	
SFSB2120	●	6	12	12						

HARD 1 BALL

SFSB Type

■ SFSB type Recommended cutting conditions

● Roughing - Semi finishing

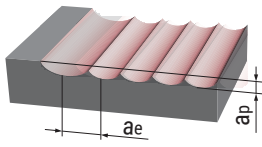
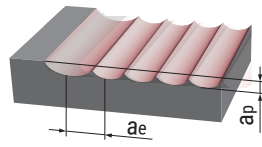
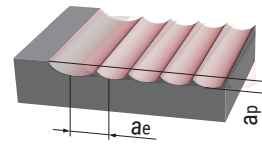
Material		Carbon steel (S50C, S55C) below 250HB		Alloy steel, Tool steel, Mold steel (SKD, SKH, NAK) below 45HRC		Hardened steel (SKD61, DAC, DHA) 42~52HRC	
Type of machining		 $a_p \leq 0.1D_c$ $a_e \leq 0.3D_c$		 $a_p \leq 0.1D_c$ $a_e \leq 0.3D_c$		 $a_p \leq 0.1D_c$ (MAX 0.5mm) $a_e \leq 0.3D_c$	
R (mm)	ϕD_c (mm)	n (min ⁻¹)	Vf (mm/min)	n (min ⁻¹)	Vf (mm/min)	n (min ⁻¹)	Vf (mm/min)
0.5	1	31,800	1,590	31,800	1,590	30,200	1,210
1	2	23,900	1,910	23,900	1,910	22,300	1,560
1.5	3	19,100	2,480	19,100	2,290	18,000	1,800
2	4	14,300	2,290	14,300	2,150	13,500	1,620
2.5	5	11,500	2,190	11,500	2,070	10,800	1,620
3	6	9,500	2,090	9,500	1,900	9,000	1,620
4	8	7,200	1,940	7,200	1,800	6,800	1,500
5	10	5,700	1,820	5,700	1,710	5,400	1,460
6	12	4,800	1,540	4,800	1,440	4,500	1,220

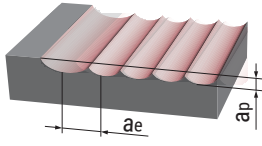
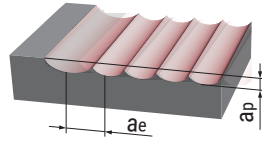
Material		Hardened steel (SKD11, SKH51, SLD) 55~62HRC		Hardened steel (SKH, HAP) 63~70HRC	
Type of machining		 $a_p \leq 0.05D_c$ (MAX 0.3mm) $a_e \leq 0.15D_c$		 $a_p \leq 0.05D_c$ (MAX 0.3mm) $a_e \leq 0.15D_c$	
R (mm)	ϕD_c (mm)	n (min ⁻¹)	Vf (mm/min)	n (min ⁻¹)	Vf (mm/min)
0.5	1	28,600	1,140	27,100	810
1	2	19,100	1,150	17,500	700
1.5	3	17,000	1,360	14,900	890
2	4	12,700	1,270	11,100	890
2.5	5	10,200	1,220	8,900	890
3	6	8,500	1,280	7,400	890
4	8	6,400	1,280	5,600	840
5	10	5,100	1,280	4,500	900
6	12	4,200	1,050	3,700	740

Note

1. These cutting conditions are for general guidance. In case of ramping angle over 15° reduce cutting conditions by 70%.
2. The figures should be adjusted according to machining shape, purpose and rigidity of machine and work clamping.
3. If rpm available is lower than that recommended, reduce the feed rate proportionately.

HARD 1 BALL

SFSB Type

■ SFSB type Recommended cutting conditions

● Finishing

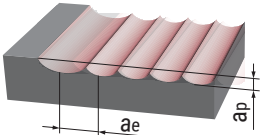
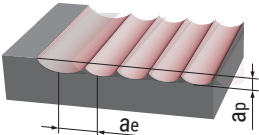
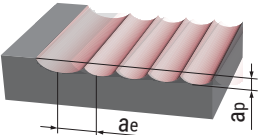
Material		Carbon steel (S50C, S55C) below 250HB		Alloy steel, Tool steel, Mold steel (SKD, SKH, NAK) below 45HRC		Hardened steel (SKD61, DAC, DHA) 42~52HRC	
Type of machining		 $a_p \leq 0.05D_c$ $a_e \leq 0.02D_c$		 $a_p \leq 0.05D_c$ $a_e \leq 0.02D_c$		 $a_p \leq 0.05D_c$ $a_e \leq 0.02D_c$	
R (mm)	ϕD_c (mm)	n (min ⁻¹)	Vf (mm/min)	n (min ⁻¹)	Vf (mm/min)	n (min ⁻¹)	Vf (mm/min)
0.5	1	38,200	3,440	38,200	3,440	35,000	2,450
1	2	27,100	3,250	27,100	3,250	25,500	2,550
1.5	3	21,200	3,390	21,200	3,180	20,200	2,630
2	4	15,900	3,340	15,900	3,180	15,100	2,270
2.5	5	12,700	2,670	12,700	2,540	12,100	2,420
3	6	10,600	2,860	10,600	2,650	10,100	2,530
4	8	8,000	2,560	8,000	2,400	7,600	2,280
5	10	6,400	2,370	6,400	2,240	6,000	1,920
6	12	5,300	1,960	5,300	1,860	5,000	1,600

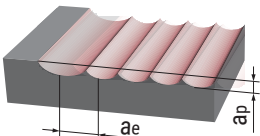
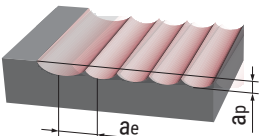
Material		Hardened steel (SKD11, SKH51, SLD) 55~62HRC		Hardened steel (SKH, HAP) 63~70HRC	
Type of machining		 $a_p \leq 0.05D_c$ $a_e \leq 0.02D_c$		 $a_p \leq 0.03D_c$ $a_e \leq 0.02D_c$	
R (mm)	ϕD_c (mm)	n (min ⁻¹)	Vf (mm/min)	n (min ⁻¹)	Vf (mm/min)
0.5	1	31,800	1,590	30,200	1,210
1	2	22,300	2,010	19,100	1,530
1.5	3	19,100	2,290	15,900	1,910
2	4	14,300	2,150	11,900	1,790
2.5	5	11,500	2,070	9,500	1,710
3	6	9,500	1,900	8,000	1,600
4	8	7,200	1,800	6,000	1,200
5	10	5,700	1,710	4,800	1,200
6	12	4,800	1,440	4,000	1,000

Note

1. These cutting conditions are for general guidance. In case of ramping angle over 15° reduce cutting conditions by 70%.
2. The figures should be adjusted according to machining shape, purpose and rigidity of machine and work clamping.
3. If rpm available is lower than that recommended, reduce the feed rate proportionately.

ONE CUT BALL 70

DH-OCHB Type

One-Cut Ball 70

UP TO 70HRC

4-flute high-efficiency
carbide ball nose end mill

Anti-vibration with High rigidity
& Unequal Spacing Teeth Geometry

Helix angle 45°,
Low cutting force /
High cutting performance

Excellent tool life for
Hardened Materials with
Newly developed "DH coating"



Special edge geometry in
center enables smooth chip
ejection and control
clogging of chips, allows
stable machining.

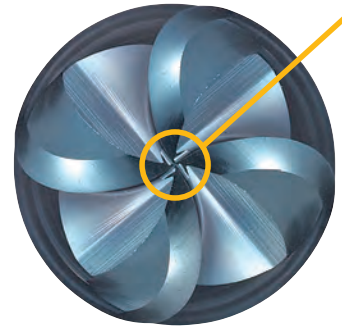

New PVD coating <DH coating>

● Properties of DIJET PVD coating

	DH coating	DV coating	DZ coating (TiAlN)	DX coating (TiCN)	JC coating (TiN)
Hardness (Hv)	3,500~3,700	3,300~3,500	2,800~2,900	2,500~2,600	2,100~2,200
Oxidation temperature (°C)	1,100~1,200	1,000~1,100	700~800	300~400	400~500
Coefficient of friction	0.5	0.65	0.6	0.45	0.45

ONE CUT BALL 70 **DH-OCHB Type**

DH-OCHB
TYPE

4-Flut Ball Nose Endmill

● Helix angle 45°

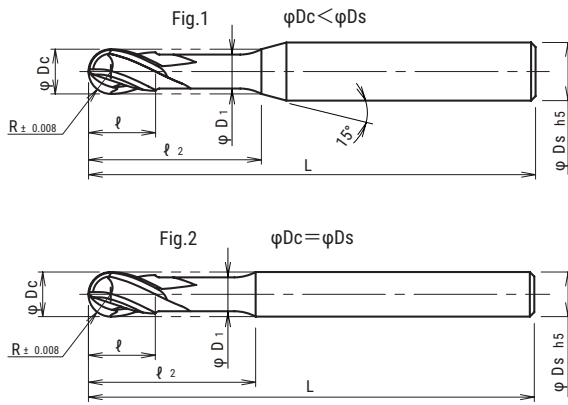

Cat.No.	Stock	Dimensions (mm)							Fig.
		R	φDc	ℓ	ℓ2	L	φD1	φDs	
DH-OCHB4010S04	●	0.5	1	1.5	3	50	0.95	4	1
DH-OCHB4010S06	●	0.5	1	1.5	3		0.95	6	
DH-OCHB4020S04	●	1	2	3	6		1.9	4	
DH-OCHB4020S06	●	1	2	3	6		1.9	6	
DH-OCHB4030	●	1.5	3	4.5	9	70	2.9	6	
DH-OCHB4040	●	2	4	6	12		3.8		
DH-OCHB4050	●	2.5	5	7.5	15	80	4.8		
DH-OCHB4060	●	3	6	9	18	90	5.7		
DH-OCHB4080	●	4	8	12	24	100	7.6	8	
DH-OCHB4100	●	5	10	15	30		9.5		10
DH-OCHB4120	●	6	12	18	36		11.4		12

■ Tolerance (mm)

R of ball nose	Tolerance of R	Tolerance of Dc
R0.5~R1	±0.005	0 -0.010
R1.5~R2	±0.008	0 -0.010
R2.5~R6	±0.008	0 -0.015

ONE CUT BALL 70

DH-OCHB Type

■ DH-OCHB type Recommended cutting conditions

● Finishing

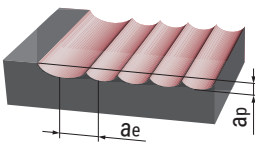
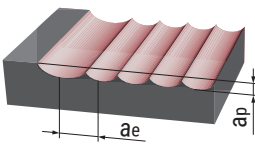
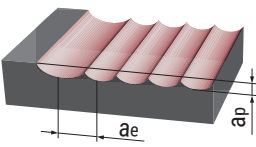
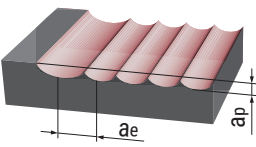
Material		Alloy steel, Tool steel, Mold steel (SKD, SKH, NAK) below 45HRC		Hardened steel (SKD61, DAC, DHA) 42~52HRC		Hardened steel (SKD11, SLD, DC11) 55~62HRC		Hardened steel (SKH, HAP) 63~70HRC	
Type of machining		 $a_p \leq 0.03D_c$ $a_e \leq 0.03D_c$		 $a_p \leq 0.03D_c$ $a_e \leq 0.03D_c$		 $a_p \leq 0.03D_c$ $a_e \leq 0.03D_c$		 $a_p \leq 0.03D_c$ $a_e \leq 0.03D_c$	
R (mm)	ϕD_c (mm)	n (min ⁻¹)	Vf (mm/min)	n (min ⁻¹)	Vf (mm/min)	n (min ⁻¹)	Vf (mm/min)	n (min ⁻¹)	Vf (mm/min)
0.5	1	30,000	1,600	30,000	1,400	30,000	1,200	30,000	800
1	2	30,000	3,200	30,000	2,000	25,500	2,000	19,000	1,000
1.5	3	25,500	4,000	21,200	3,000	17,000	2,000	12,700	1,000
2	4	19,100	4,000	15,900	3,000	12,700	2,000	9,500	1,000
2.5	5	15,300	4,000	12,700	3,000	10,200	2,000	7,600	1,000
3	6	12,700	4,000	10,600	3,000	8,500	2,000	6,400	1,000
4	8	9,500	4,000	8,000	3,000	6,400	2,000	4,800	1,000
5	10	7,600	4,000	6,400	3,000	5,100	2,000	3,800	1,000
6	12	6,400	4,000	5,300	3,000	4,200	2,000	3,200	1,000

■ DH-OCHB type Recommended cutting conditions

● Roughing & Semi-finishing

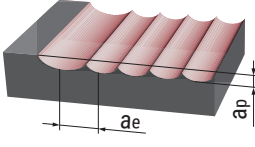
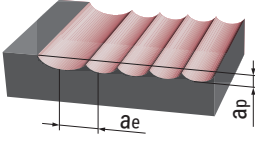
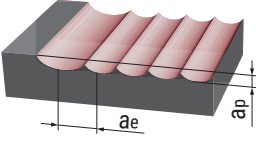
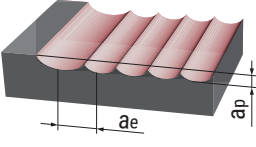
Material		Alloy steel, Tool steel, Mold steel (SKD, SKH, NAK) below 45HRC		Hardened steel (SKD61, DAC, DHA) 42~52HRC		Hardened steel (SKD11, SLD, DC11) 55~62HRC		Hardened steel (SKH, HAP) 63~70HRC					
Type of machining		 $a_p \leq 1.2D_c$ $a_e \leq 0.2D_c$		 $a_p \leq 1.2D_c$ $a_e \leq 0.2D_c$		 $a_p \leq 1.2D_c$ $a_e \leq 0.2D_c$		 $a_p \leq 1.0D_c$ $a_e \leq 0.1D_c$					
R (mm)	ϕD_c (mm)	n (min ⁻¹)	Vf (mm/min)	$a_p \times a_e$	n (min ⁻¹)	Vf (mm/min)	$a_p \times a_e$	n (min ⁻¹)	Vf (mm/min)	$a_p \times a_e$	n (min ⁻¹)	Vf (mm/min)	$a_p \times a_e$
0.5	1	30,000	1,500	0.024	30,000	1,400	0.024	30,000	1,200	0.02	28,800	750	0.006
1	2	28,600	3,000	0.095	23,800	2,250	0.095	19,100	1,500	0.08	14,400	750	0.025
1.5	3	19,100	3,000	0.22	15,900	2,250	0.22	12,700	1,500	0.18	9,500	750	0.05
2	4	14,300	3,000	0.38	11,900	2,250	0.38	9,500	1,500	0.32	7,200	750	0.10
2.5	5	11,500	3,000	0.60	9,500	2,250	0.60	7,600	1,500	0.50	5,700	750	0.15
3	6	9,500	3,000	0.86	8,000	2,250	0.86	6,400	1,500	0.72	4,800	750	0.22
4	8	7,200	3,000	1.54	6,000	2,250	1.54	4,800	1,500	1.28	3,600	750	0.38
5	10	5,700	3,000	2.40	4,800	2,250	2.40	3,800	1,500	2.00	2,900	750	0.60
6	12	4,800	3,000	3.46	4,000	2,250	3.46	3,200	1,500	2.88	2,400	750	0.86

Note

- These cutting conditions are for general guidance.
- The figures should be adjusted according to machining shape, purpose and rigidity of machine and work clamping.
- Recommended ramping angle is under 1° (Max. 3°). In case of ramping angle under 1°, apply standard conditions above. In case of over 1°, reduce (Vf) according to actual machining conditions.

Solid Carbide Radius Endmill for Heat-Resistant Alloy DV-OCSAR Type

DV-OCSAR
TYPE

For Heat resistant alloy, Titanium alloy

- 4 flutes
- Helix angle 42° - 45°

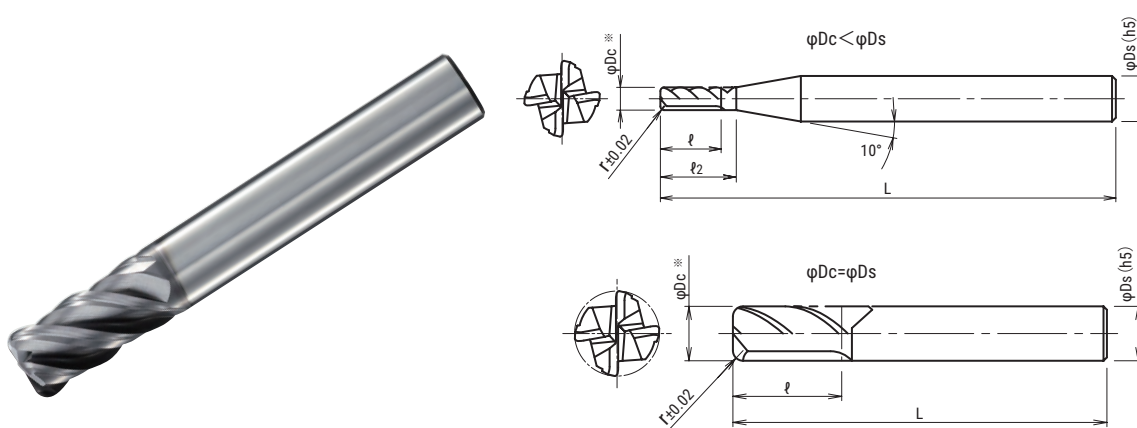

Cat.No.	Stock	Dimensions (mm)						
		r	φDc	ℓ	ℓ2	L	φDs	
DV-OCSAR4030-05	●	0.5	3	8	10	60	6	
DV-OCSAR4040-05	●		4	11	13			
DV-OCSAR4040-10	●	1		5	13			15
DV-OCSAR4050-05	●	0.5						
DV-OCSAR4050-10	●	1	6	19	75			8
DV-OCSAR4060-05	●	0.5						
DV-OCSAR4060-10	●	1	8	22	80	10		
DV-OCSAR4080-05	●	0.5						
DV-OCSAR4080-10	●	1	10	26	100	12		
DV-OCSAR4080-20	●	2						
DV-OCSAR4100-05	●	0.5	12	26	100	12		
DV-OCSAR4100-10	●	1						
DV-OCSAR4100-20	●	2	12	26	100	12		
DV-OCSAR4120-05	●	0.5						
DV-OCSAR4120-10	●	1	12	26	100	12		
DV-OCSAR4120-20	●	2						
DV-OCSAR4120-30	●	3	12	26	100	12		
DV-OCSAR4120-30	●	3						

■ Tolerance (mm)

Tool dia. (φDc)	Tolerance (φDc)
≤ dia. 6	0 -0.015
> dia. 6	0 -0.02

Solid Carbide Radius Endmill for Heat-Resistant Alloy

DV-OCSAR Type

■ DV-OCSAR type Recommended cutting conditions

● Side milling

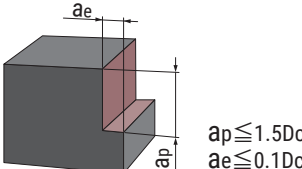
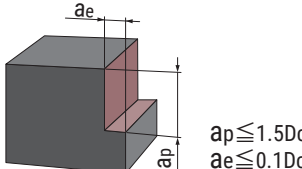
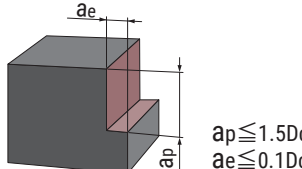
Material	Stainless steel (SUS304, 316, 317)17Cr		Titanium alloy (Ti-6Al-4V)		Heat resistant alloy (INCO718)	
Type of machining						
φDc (mm)	n (min ⁻¹)	Vf (mm/min)	n (min ⁻¹)	Vf (mm/min)	n (min ⁻¹)	Vf (mm/min)
3	11,000	1,200	11,000	1,200	4,200	320
4	8,000	1,200	8,000	1,200	3,200	320
5	6,400	1,200	6,400	1,200	2,500	320
6	5,400	1,200	5,400	1,200	2,100	320
8	4,000	1,200	4,000	1,200	1,600	320
10	3,200	1,300	3,200	1,300	1,300	320
12	2,700	1,300	2,700	1,300	1,100	280
16	2,000	960	2,000	960	800	200
20	1,600	770	1,600	770	640	160

Note

1. These cutting conditions are for general guidance.
2. The figures should be adjusted according to machining shape, purpose and rigidity of machine and work clamping.
3. Down cutting is recommended.
4. Wet cutting is recommended. For heat resistant alloy, use of cutting fluid is more effective.

● Slot milling

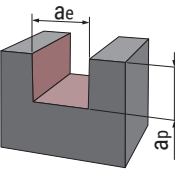
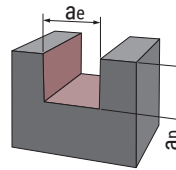
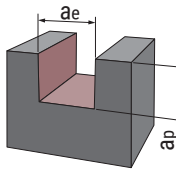
Material	Stainless steel (SUS304)		Titanium alloy (Ti-6Al-4V)		Heat resistant alloy (INCO718)	
Type of machining						
φDc (mm)	n (min ⁻¹)	Vf (mm/min)	n (min ⁻¹)	Vf (mm/min)	n (min ⁻¹)	Vf (mm/min)
3	8,500	540	8,500	540	3,200	160
4	6,400	580	6,400	580	2,400	170
5	5,100	600	5,100	600	1,900	175
6	4,200	600	4,200	600	1,600	180
8	3,200	640	3,200	640	1,200	190
10	2,500	630	2,500	630	950	190
12	2,100	630	2,100	630	800	160
16	1,600	480	1,600	480	600	120
20	1,300	390	1,300	390	480	100

Note

1. These cutting conditions are for general guidance.
2. The figures should be adjusted according to machining shape, purpose and rigidity of machine and work clamping.
3. Wet cutting is recommended. For heat resistant alloy, use of cutting fluid is more effective.

Chamfering Cutter for High Hardened Materials

SFSV Type

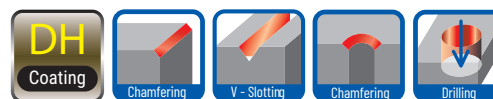

SFSV
TYPE

Chamfering Cutter for Hard Materials

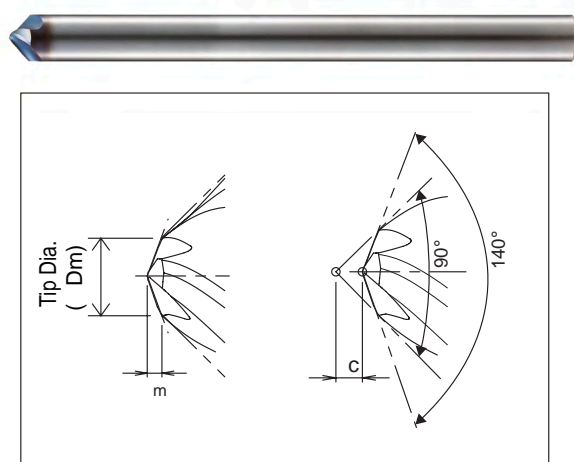

Fig.1

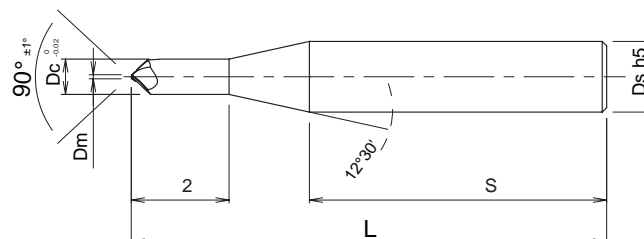
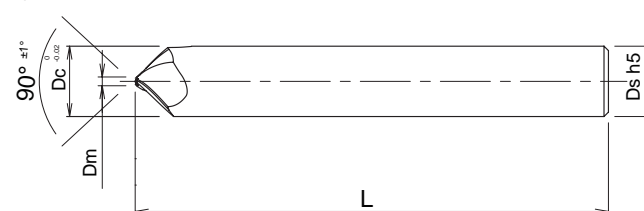

Fig.2



Cat.No.	Stock	Grade	No. of Flutes	Dimensions(mm)								Fig.
				φDc	φDm	L	l_2	l_s	l_m	l_c	φDs	
SFSV3010S04	●	DH110	3	1	0.2	50	3.0	40.2	0.036	0.064	4	1
SFSV3020S06	●			2	0.4	50	4.5	35.5	0.073	0.127	6	1
SFSV3030S06	●			3	0.6	60	8.0	45.2	0.109	0.191	6	1
SFSV3040S06	●			4	0.8	70	10.5	55.0	0.146	0.254	6	1
SFSV3050S06	●			5	1.0	80	12.5	65.2	0.182	0.318	6	1
SFSV3060S06	●			6	1.2	90	-	-	0.218	0.382	6	2
SFSV3080S08	●			8	1.5	100	-	-	0.273	0.477	8	2
SFSV3100S10	●			10	1.8	100	-	-	0.328	0.572	10	2
SFSV3120S12	●			12	2.1	110	-	-	0.382	0.668	12	2



Recommended cutting conditions

● C Chamfering

Work materials	Carbon ~250HB				Mold Steel 38 ~43HRC				Hardened Steel ~60HRC			
	C=0.2D				C=0.2D				C=0.2D			
Depth of cut	C=0.2D				C=0.2D				C=0.2D			
Tool dia. φDc (mm)	VC(min)	n(min ⁻¹)	f(mm/rev)	V f(mm/min)	VC(min)	n(min ⁻¹)	f(mm/rev)	V f(mm/min)	VC(min)	n(min ⁻¹)	f(mm/rev)	V f(mm/min)
1	50	16,000	0.06	960	50	16,000	0.06	960	30	9,600	0.06	580
2	50	8,000	0.06	480	50	8,000	0.06	480	30	4,800	0.06	290
3	150	16,000	0.18	2,880	150	16,000	0.18	2,880	70	7,400	0.06	440
4	150	12,000	0.18	2,200	150	12,000	0.18	2,200	70	5,600	0.06	340
5	150	9,500	0.18	1,720	150	9,500	0.18	1,720	80	5,000	0.09	450
6	150	8,000	0.18	1,440	150	8,000	0.18	1,440	80	4,200	0.09	380
8	225	9,000	0.3	2,700	225	9,000	0.3	2,700	100	4,000	0.15	600
10	225	7,200	0.3	2,160	225	7,200	0.3	2,160	100	3,200	0.15	480
12	225	6,000	0.3	1,800	225	6,000	0.3	1,800	100	2,600	0.15	390

Note

1. These cutting conditions are for general guidance.
2. The figures should be adjusted according to machining shape, purpose and rigidity of machine and work clamping.
3. Using air blow or mist is recommended.

Chamfering Cutter for High Hardened Materials

SFSV Type



■ Recommended cutting conditions

● Centering

Work materials	Carbon ~250HB				Mold Steel 38 ~43HRC				Hardened Steel ~60HRC			
Depth of cut	$ap \leq 0.1D$				$ap \leq 0.1D$				$ap \leq 0.1D$			
Tool dia. ϕD_c (mm)	VC(min)	$n(\text{min}^{-1})$	$f(\text{mm/rev})$	$Vf(\text{mm/min})$	VC(min)	$n(\text{min}^{-1})$	$f(\text{mm/rev})$	$Vf(\text{mm/min})$	VC(min)	$n(\text{min}^{-1})$	$f(\text{mm/rev})$	$Vf(\text{mm/min})$
1	50	16,000	0.01	160	50	16,000	0.01	160	30	9,600	0.01	96
2	50	8,000	0.01	80	50	8,000	0.01	80	30	4,800	0.01	48
3	150	16,000	0.01	160	150	16,000	0.01	160	70	7,400	0.01	74
4	150	12,000	0.01	120	150	12,000	0.01	120	70	5,600	0.01	56
5	150	9,500	0.01	95	150	9,500	0.01	95	80	5,000	0.01	50
6	150	8,000	0.01	80	150	8,000	0.01	80	80	4,200	0.01	42
8	225	9,000	0.01	90	225	9,000	0.01	90	100	4,000	0.01	40
10	225	7,200	0.01	72	225	7,200	0.01	72	100	3,200	0.01	32
12	225	6,000	0.01	60	225	6,000	0.01	60	100	2,600	0.01	26



● C Chamfering (hole)

Work materials	Carbon ~250HB				Mold Steel 38 ~43HRC				Hardened Steel ~60HRC			
Tool dia. ϕD_c (mm)	VC(min)	$n(\text{min}^{-1})$	$f(\text{mm/rev})$	$Vf(\text{mm/min})$	VC(min)	$n(\text{min}^{-1})$	$f(\text{mm/rev})$	$Vf(\text{mm/min})$	VC(min)	$n(\text{min}^{-1})$	$f(\text{mm/rev})$	$Vf(\text{mm/min})$
1	50	16,000	0.03	480	50	16,000	0.03	480	7.5	2,400	0.06	140
2	50	8,000	0.03	240	50	8,000	0.03	240	7.5	1,200	0.06	72
3	150	16,000	0.09	1,440	150	16,000	0.09	1,440	15	1,600	0.09	140
4	150	12,000	0.09	1,100	150	12,000	0.09	1,100	15	1,200	0.09	110
5	150	9,500	0.09	860	150	9,500	0.09	860	15	950	0.09	86
6	150	8,000	0.09	720	150	8,000	0.09	720	15	800	0.09	72
8	225	9,000	0.15	1,350	225	9,000	0.15	1,350	25	1,000	0.15	150
10	225	7,200	0.15	1,080	225	7,200	0.15	1,080	25	800	0.15	120
12	225	6,000	0.15	900	225	6,000	0.15	900	25	650	0.15	98



● Slotting

Work materials	Carbon ~250HB				Mold Steel 38 ~43HRC				Hardened Steel ~60HRC			
Depth of cut	$ap \leq 0.25D$				$ap \leq 0.25D$				$ap \leq 0.25D$			
Tool dia. ϕD_c (mm)	VC(min)	$n(\text{min}^{-1})$	$f(\text{mm/rev})$	$Vf(\text{mm/min})$	VC(min)	$n(\text{min}^{-1})$	$f(\text{mm/rev})$	$Vf(\text{mm/min})$	VC(min)	$n(\text{min}^{-1})$	$f(\text{mm/rev})$	$Vf(\text{mm/min})$
1	50	16,000	0.06	960	50	16,000	0.06	960	20	6,400	0.06	380
2	50	8,000	0.06	480	50	8,000	0.06	480	20	3,200	0.06	190
3	150	16,000	0.09	1,440	150	16,000	0.09	1,440	70	7,400	0.06	440
4	150	12,000	0.09	1,100	150	12,000	0.09	1,100	70	5,600	0.06	340
5	150	9,500	0.09	860	150	9,500	0.09	860	40	2,500	0.075	188
6	150	8,000	0.09	720	150	8,000	0.09	720	40	2,100	0.075	160
8	225	9,000	0.15	1,350	225	9,000	0.15	1,350	50	2,000	0.15	300
10	225	7,200	0.15	1,080	225	7,200	0.15	1,080	50	1,600	0.15	240
12	225	6,000	0.15	900	225	6,000	0.15	900	50	1,300	0.15	200

Note

1. These cutting conditions are for general guidance.
2. The figures should be adjusted according to machining shape, purpose and rigidity of machine and work clamping.
3. Using air blow or mist is recommended.

GRADES

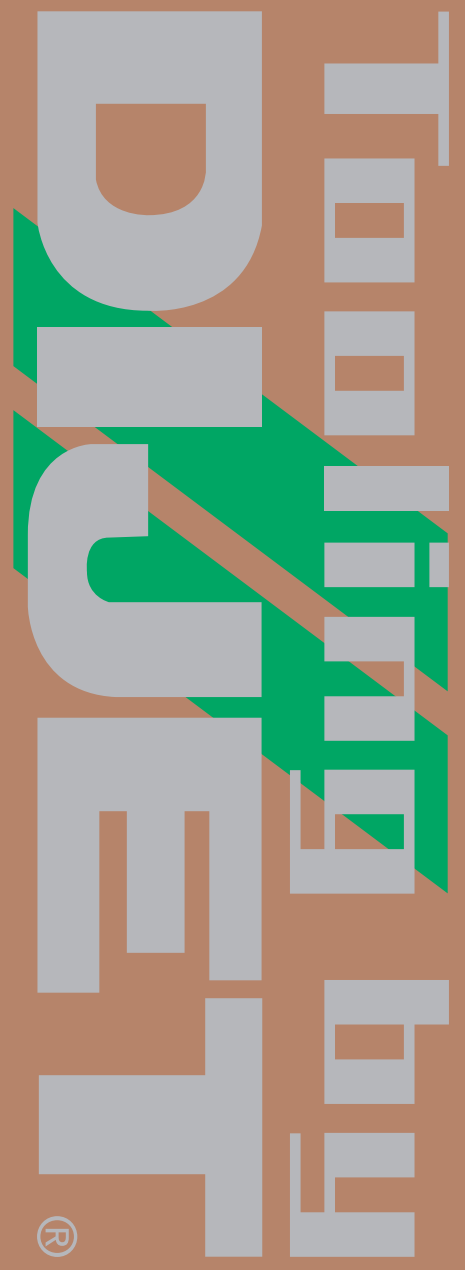

DIJET GRADES FOR MILLING TOOLS

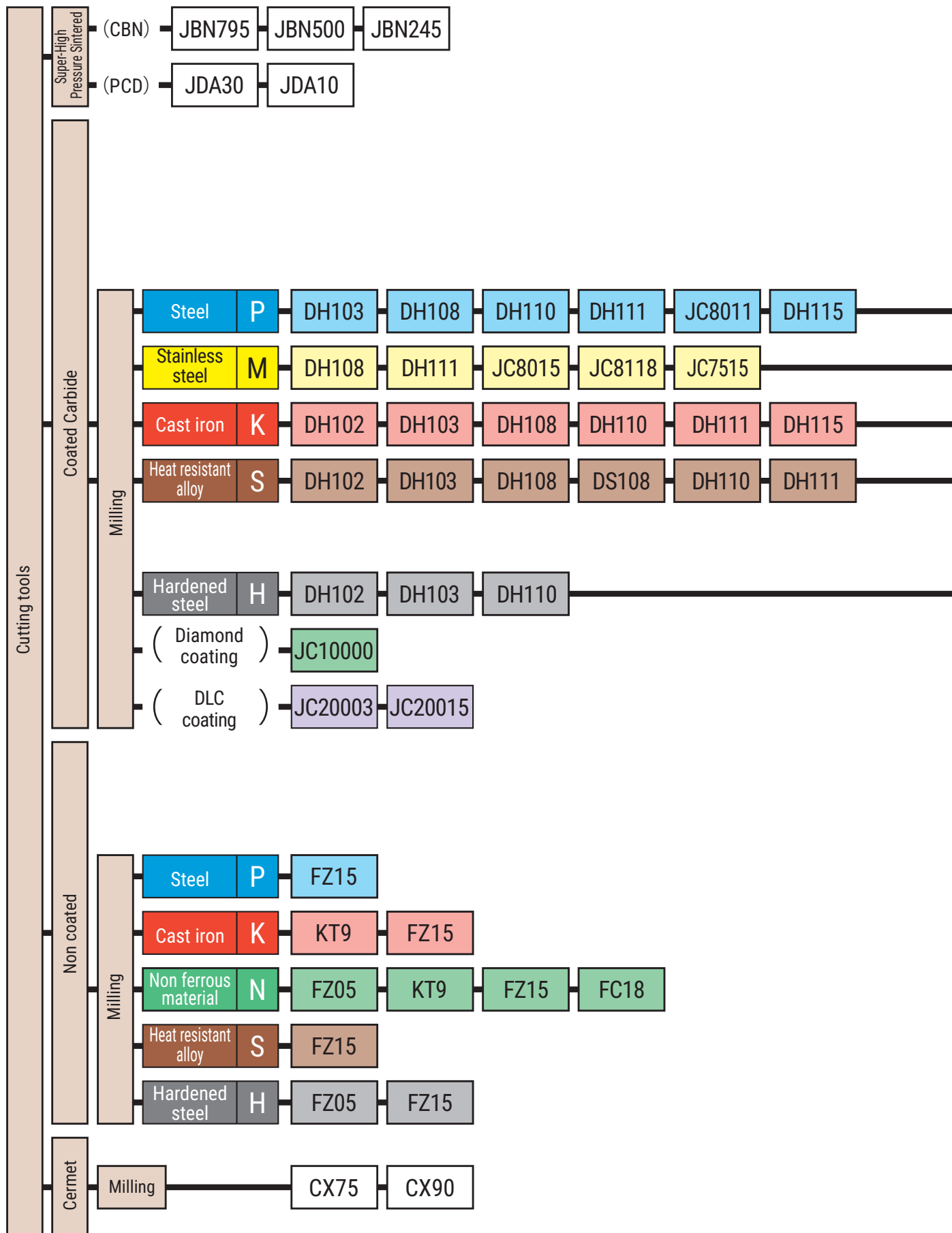

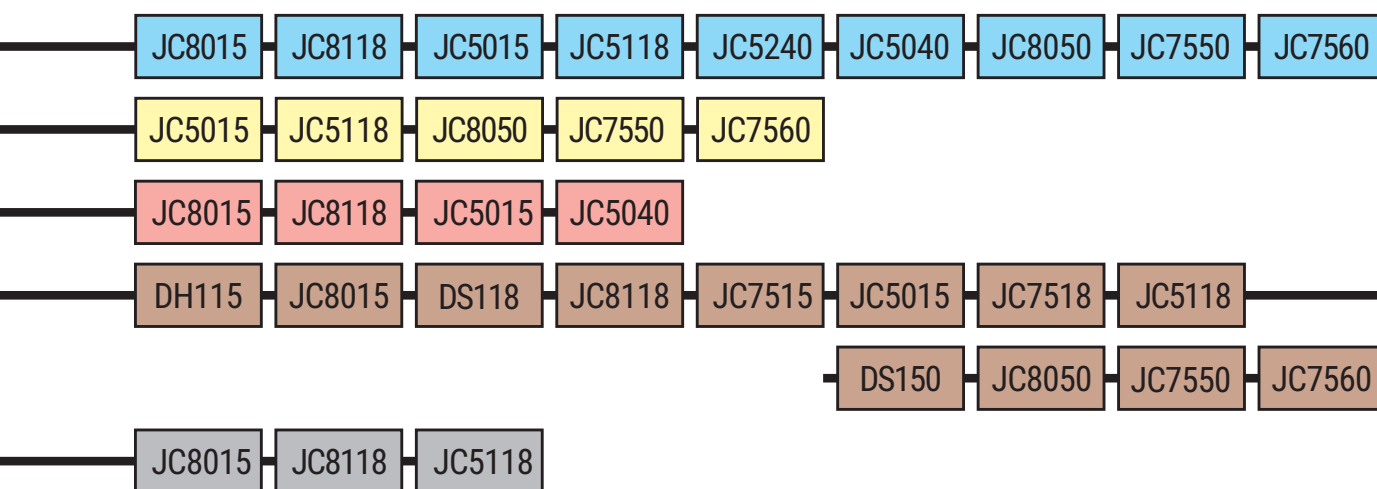

DIJET GRADES FOR MILLING TOOLS

Material		P					M					K			
Application		Finishing ← → Roughing					Finishing ← → Roughing					Finishing ← → Roughing			
ISO		P01	P10	P20	P30	P40	M01	M10	M20	M30	M40	K01	K10	K20	K30
PVD coating	DH	DH103 DH108 DH110 DH111 DH115					DH108 DH111					DH102 DH103 DH108 DH110 DH111 DH115			
	DS														
	JC8000 (DV)	JC8011 JC8015 JC8118					JC8015 JC8118					JC8015 JC8118			
	JC7500				JC8050		JC7515 JC7550 JC7560				JC7550 JC7560				
	JC5000 (DZ)		JC5015 JC5118 JC5240 JC5040				JC5015 JC5118					JC5015 JC5240			
DLC coating															
Diamond coating															
Non coated												KT9 FZ15			
Cermet		CX75 CX90					CX75					CX75			
Super-High Pressure Sintered	CBN											JBN795 JBN500 JBN245			
	Diamond														

Material		N				S				H			
Application		Finishing ← → Roughing				Finishing ← → Roughing				Finishing ← → Roughing			
ISO		N01	N10	N20	N30	S01	S10	S20	S30	H01	H10	H20	H30
PVD coating	DH					DH102				DH102			
						DH103				DH103			
						DH108							
						DH110				DH110			
						DH111							
						DH115							
	DS					DS108							
						DS118							
						DS150							
	JC8000 (DV)					JC8015				JC8015			
						JC8118				JC8118			
						JC8050							
	JC7500					JC7515							
						JC7518							
						JC7550							
						JC7560							
	JC5000 (DZ)					JC5015							
						JC5118				JC5118			
	DLC coating	JC20003											
			JC20015										
	Diamond coating	JC10000											
	Non coated	FZ05								FZ05			
		KT9											
		FZ15				FZ15				FZ15			
		FC18											
	Cermet												
Super-High Pressure Sintered	CBN									JBN795			
										JBN500			
	Diamond	JDA30											
		JDA10											

SPARE PARTS

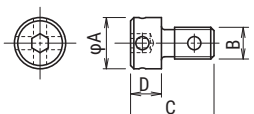

SPARE PARTS

Geometry	Cat.No.	Dimensions						Wrench size
		A	B	C	D	E	α°	
	ADS-513	7.8	M5×0.5	13.0	5.0	—	—	AD-2080
	ADS-514	5.6	M5×0.5	14.5	6.5	—	—	AD-2080

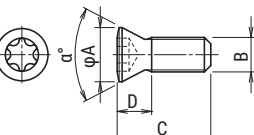
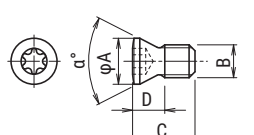
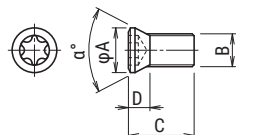
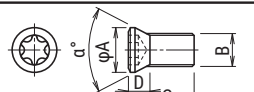
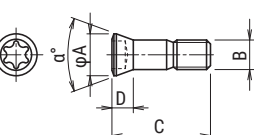
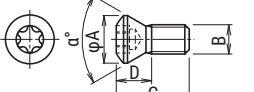
Geometry	Cat.No.	Dimensions						Wrench size	Torque (N·m)
		A	B	C	D	E	α°		
	CSW-206	3.5	M2.5×0.45	5.0	2.4	—	55	T-8	0.9
	CSW-406H	5.0	M4×0.7	6.0	3.6	—	43	T-15	3.6
	CSW-407	5.0	M4×0.7	7.0	3.6	—	43	T-15	3.6
	CSW-408H	5.0	M4×0.7	8.0	3.6	—	43	T-15	3.6
	CSW-513H	7.0	M5×0.8	13.0	4.4	—	63	T-20	5.5
	CSW-510	6.4	M5×0.8	11.0	4.5	—	43	T-20	5.5
	DSW-1840H	2.5	M1.8×0.35	4.0	2.0	—	55	T-6	0.4
	DSW-2045H	3.0	M2×0.4	4.5	2.3	—	60	T-7	0.5
	DSW-2563H	3.45	M2.5×0.45	6.3	2.6	—	55	T-8	1.1
	DSW-306H	4.3	M3×0.5	6.5	3.2	—	55	T-10	1.8
	DSW-307	4.3	M3×0.5	7.5	2.8	—	55	T-10	1.4
	DSW-307H	4.3	M3×0.5	7.6	3.2	—	55	T-10	2.1
	DSW-309H	4.3	M3×0.5	9.0	3.2	—	55	T-10	2.1
	DSW-4075H	5.2	M4×0.7	7.5	3.5	—	55	T-15	3.6
	DSW-408	6.0	M4×0.7	8.5	3.6	—	55	T-15	3.6
	DSW-4085	5.3	M4×0.7	8.5	3.5	—	55	T-15	3.6
	DSW-410H	5.3	M4×0.7	10.0	3.7	—	55	T-15	3.6
	DSW-4510H	6.8	M4.5×0.75	10.0	4.7	—	55	T-20	6.0
	DSW-4512H	6.8	M4.5×0.75	12.5	5.2	—	55	T-20	6.0
	DSW-509	7.0	M5×0.8	9.5	4.9	—	55	T-20	6.1
DSW-511H	7.0	M5×0.8	11.5	4.9	—	55	T-20	6.1	
	ESW-206	3.6	M2.5×0.45	6.0	2.0	—	60	T-8	0.9
	ESW-304	4.0	M3×0.5	4.5	2.0	—	55	T-8	1.4
	ESW-306	4.0	M3×0.5	6.0	2.0	—	55	T-8	1.4
	ESW-307	4.0	M3×0.5	7.5	2.0	—	55	T-8	1.4
	ESW-405	5.3	M4×0.7	5.9	2.7	—	55	T-15	3.1
	ESW-406	5.3	M4×0.7	6.6	2.7	—	55	T-15	3.1
	ESW-408	5.3	M4×0.7	8.0	2.7	—	55	T-15	3.1
	ESW-410	5.3	M4×0.7	10.0	2.7	—	55	T-15	3.1
	ESW-507	6.8	M5×0.8	7.5	3.4	—	55	T-25	5.5
	ESW-508	6.8	M5×0.8	8.2	3.4	—	55	T-25	5.5
	ESW-510	6.8	M5×0.8	10.0	3.4	—	55	T-25	5.5
	FSW-2005H	2.5	M2×0.25	5.0	1.3	—	40	T-6	0.5
	FSW-2506H	3.0	M2.5×0.35	6.6	1.5	—	40	T-7	0.9
	FSW-3007H	3.8	M3×0.35	8.1	2.0	—	40	T-8	1.2
	FSW-3509H	4.7	M3.5×0.6	9.6	2.3	—	40	T-10	2.0
	FSW-4013H	5.8	M4×0.7	13.5	3.3	—	40	T-15	3.0
	FSW-5016H	6.8	M5×0.8	16.4	3.2	—	40	T-20	4.0
	FSW-6020	8.5	M6×1.0	20.0	4.3	—	40	T-30	6.0
	FSW-8025	11.0	M8×1.25	25.0	5.5	—	40	T-40	6.0
	FSW-8025S	11.0	M8×1.25	25.0	5.5	—	40	T-30	6.0
	HSW-614H	10.0	M6×1.0	15.0	7.3	—	60	T-30	7.5

SPARE PARTS

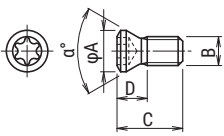
Geometry	Cat.No.	Dimensions						Wrench size	Torque (N•m)
		A	B	C	D	E	α°		
	TSW-2250	3.1	M2.2×0.45	5.0	2.3	—	60	T-7	0.6
	TSW-2556H	3.6	M2.5×0.45	5.6	2.7	—	60	T-8	1.1
	TSW-2567H	3.6	M2.5×0.45	6.7	2.7	—	60	T-8	1.1
	TSW-307H	4.3	M3×0.5	7.6	3.1	—	60	T-10	2.1
	TSW-3509H	5.3	M3.5×0.6	9.0	4.5	—	60	T-15	3.0
	TSW-3510H	5.3	M3.5×0.6	10.0	4.5	—	60	T-15	3.0
	TSW-3512H	5.3	M3.5×0.6	11.5	4.5	—	60	T-15	3.0
	TSW-408	5.5	M4×0.7	8.0	3.3	—	60	T-15	3.1
	TSW-410H	5.3	M4×0.7	10.0	3.6	—	60	T-15	3.5
	TSW-511	7.0	M5×0.8	11.0	5.0	—	60	T-20	5.5
	TSW-612	8.5	M6×1.0	12.0	4.8	—	60	T-25	7.5
	TSW-614H	8.5	M6×1.0	14.0	6.2	—	60	T-25	7.5

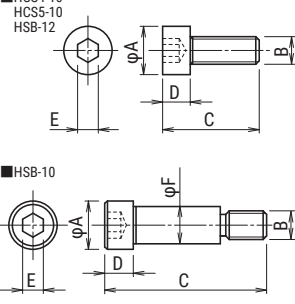
Geometry	Cat.No.	Dimensions						Wrench size	Torque (N•m)
		A	B	C	D	E	F		
	HCS4-10	7.0	M4×0.7	14.0	4.0	3.0	—	—	—
	HCS5-10	8.5	M5×0.8	15.0	5.0	4.0	—	—	—
	HSB-10	17.0	M10×1.5	56.0	10.0	8.0	13	—	—
	HSB-12	18.0	M12×1.75	62.0	12.0	10.0	—	—	—

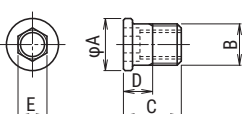
Geometry	Cat.No.	Dimensions						Wrench size	Torque (N•m)
		A	B	C	D	E	F		
	SSW-535	6.3	M5×0.5	7.0	3.1	3.5	—	—	6.5

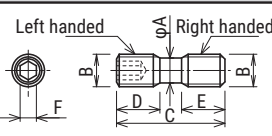
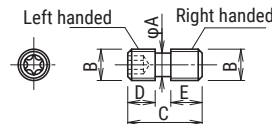
Geometry	Cat.No.	Dimensions						Wrench size	Torque (N•m)
		A	B	C	D	E	F		
	LS-101	4.6	M6×1.0	16.0	6.5	6.5	3.0	—	6.0
	LS-106	4.6	M6×1.0	14.5	6.5	5.0	3.0	—	6.0
	LS-107	4.6	M6×1.0	13.0	5.0	5.0	3.0	—	6.0
	LS-109	5.5	M7×0.75	19.0	7.5	8.0	—	T-25	7.0
	LS-110	4.8	M6×0.75	22.0	8.0	8.0	—	T-15	6.0

SPARE PARTS

Geometry	Cat. No	Dimensions						Wrench size	Torque (N·m)
		A	B	C	D	E	F		
	LS-113	3.7	No.10-32UNF	10.2	4.5	4.1	2.4	—	—

Geometry	Cat. No	Dimensions						Wrench size	Torque (N·m)
		A	B	C	D	E	F		
	SLS-3	6.0	M8x1.0	20.0	8.0	8.0	4.0	—	8.0

Geometry	Cat. No	Dimensions					Wrench size
		A	B	C	D	E	
	LW-020	52.0	15.0	—	—	2.0	—
	LW-025	59.5	18.0	—	—	2.5	—
	LW-030	67.0	20.0	—	—	3.0	—
	LW-035	71.5	22.5	—	—	3.5	—
	LW-040	75.0	25.0	—	—	4.0	—
	LW-050	80.0	28.0	—	—	5.0	—
	A-030	—	60.0	80.0	28.0	3.0	—
	A-07SD	4.0	60.0	80.0	—	—	T-7
	A-08SD	4.0	70.0	80.0	—	—	T-8
	A-10SD	4.0	70.0	95.0	—	—	T-10
	A-20SD	5.0	90.0	105.0	—	—	T-20
	A-25SD	5.0	100.0	105.0	—	—	T-25
	A-06	1.7	34.5	15.0	15.0	—	T-6
	A-07	2.0	34.5	15.0	15.9	—	T-7
	A-08	2.3	39.0	19.0	19.0	—	T-8
	A-10	3.0	40.0	40.0	20.0	—	T-10
	A-15	3.5	45.0	40.0	20.0	—	T-15
	A-20W	4.0	45.0	40.0	20.0	—	T-20
	A-15T	4.0	100.0	80.0	26.0	—	T-15
	A-20	4.0	100.0	100.0	32.0	—	T-20
	A-20L	5.5	200.0	100.0	32.0	—	T-20
	A-25	4.5	100.0	100.0	32.0	—	T-25
	A-27	5.5	100.0	100.0	32.0	—	T-27
	A-30	6.0	100.0	100.0	32.0	—	T-30
	AD-2080	2.0	45.0	35.0	—	—	—

SPARE PARTS

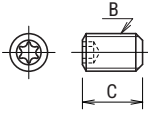
Geometry	Cat. No	Dimensions						Wrench size	Torque (N·m)
		A	B	C	D	E	F		
	RSW-05008	—	M5×0.8	8.0	—	—	—	T-10	—

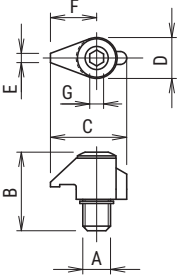
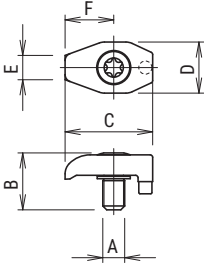
Geometry	Cat. No	Dimensions							Wrench size
		A	B	C	D	E	F	G	
	DCM-1	M5×0.8	13.8	13.8	6.8	2.0	8.5	2.5	—
	DCM-5	M6×1.0	17.0	16.5	8.9	2.0	10.0	3.0	—
	DCM-17	M4.5×0.75	11.7	18.0	10.5	5.0	10.0	—	T-20
	DCM-18	M3.5×0.6	10.0	13.0	7.6	3.0	7.2	—	T-15

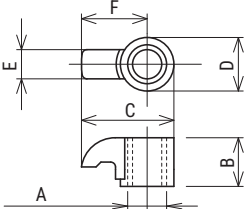
Geometry	Cat. No	Dimensions					
		A	B	C	D	E	F
	DCM-2	M8×1.0	10.0	19.0	11.0	6.0	13.5

Shape	Cat. No
	MOLY

INDEX



INDEX

Cat.No	Name	Page
--------	------	------

A

A-06	Wrench for PME, MPM, BNM06, RNM06	A108, A109, A146, A158
A-07	Wrench for BNM08, RNM08, TLZD, TEZD	A146, A158, B016, B017, B024~026
A-08	Wrench for MQT, GMX, MXG, QXP, MQX, BNM10, RNM10, XFG, MXF, TLZD, TEZD	A031, A083~085, A093~095, A146, A158, A171 B016, B017, B024~026
A-10	Wrench for SKG09, EXSAP11, BNM12, RNM12, TLZD, TEZD	A062~064, A118~120, A146, A158, B016, B017, B024~026
A-15	Wrench for SKG10, EXSKS07, EXSAP17, SSV, BNM16, RNM16, SDH, MAL, ALXM, TLZD, TEZD	A025~028, A051, A073, A123, A124, A139, A146, A158, A179 A193, A194, B016, B017, B024~026
A-15T	Wrench for SKG10, EXSKS07, EXSAP17, SSV, HDM, ALX	A050, A072, A122, A137, A177, A193
A-20	Wrench for SKG14, EXSKS09, EXSIX, HDM, HEP	A053, A074, A133, A177, A186
A-20W	Wrench for BNM20, RNM20	A025~028, A146~148, A159, A160
A-30	Wrench for BNM25, RNM25, BNM30/32, RNM30/32	A025~028, A147, A148, A159, A160
ALX○○○○○R-22	AERO CHIPPER	A193
ALXM○○○○○S○○	AERO CHIPPER	A194

B

BNM□-○○○○○○○S-○○○C	MIRROR BALL	A146
BNM□-○○○○○○○T-S○○○C	MIRROR BALL	A146
BNM-○○○	Insert for MIRROR BALL - BNM/MBX type	A149
BNM-○○○-S	Insert for MIRROR BALL - BNM/MBX type	A150
BNM-○○○-SS	Insert for MIRROR BALL - BNM/MBX type	A150
BNM-○○○-TG	Insert for MIRROR BALL - BNM/MBX type	A151
BNM-○○○-TS	Insert for MIRROR BALL - BNM/MBX type	A152

C

CSW-408H	Screw for SDH	A179, A180
CSW-513H	Screw for SKG14, EXSKS09, EXSIX	A053, A074, A133

D

DCM-17	Clamp set for HDM, HEP	A177, A186
DCM-18	Clamp set for HDM	A177, A179
DH-0CHB4○○○	ONE CUT BALL 70 - Solid carbide endmill	C025
DS-○○	Spanner	A029, A148, A160, A203, A208, A210, A213
DSW-1840H	Screw for PME, MPM	A108, A109
DSW-2045H	Screw for TLZD, TEZD	B016, B017, B024~026
DSW-2563H	Screw for MQT, MQX, QXP	A031, A093~095
DSW-306H	Screw for MSG09	A064
DSW-307H	Screw for SKG09, MSG09, TLZD, TEZD	A062, A063, B016, B017, B024~026
DSW-309H	Screw for TLZD, TEZD	B016, B017, B024~026
DSW-4075H	Screw for SSV, ALXM	A137~139, A194
DSW-4085	Screw for ALX, MAL	A193, A194
DSW-410H	Screw for HDM, SDH	A177~180
DSW-4512H	Screw for HDM	A177, A178
DV-OCSAR4○○○-○○	Solid Carbide Radius Endmill for Heat-Resistant Alloy	C027

Cat.No	Name	Page
--------	------	------

E

ENMQ100312ZER	Insert for QMMAX GII- GMX/MXG type	A086
ENMU100312ZER-HL	Insert for QMMAX GII- GMX/MXG type	A086
ENMU100412ZER-PH	Insert for QMMAX GII- GMX/MXG type	A086
ENMU100412ZER-SL	Insert for QMMAX GII- GMX/MXG type	A086
EOHW0602○○ZTR	Insert for QM MILL - PME/PME-LS/MPM type	A110
EOMT0602○○ZER	Insert for QM MILL - PME/PME-LS/MPM type	A110
EOMW060210ZER	Insert for QM MILL - PME/PME-LS/MPM type	A110
EPHW100316ZTR	Insert for QM MAX - MQX/QXP type	A096
EPMT1003○○ZER	Insert for QM MAX - MQX/QXP type	A096
EPMW100312Z□R	Insert for QM MAX - MQX/QXP type	A096
EXSAP-○○○○R-○○	EXTREME SAP 17	A122
EXSAP-○○○○-○○-S○○	EXTREME SAP 17	A123
EXSAP-○○○○-11-○○-S○○+A	EXTREME SAP 11	A119
EXSAP-○○○○R-11-○○	EXTREME SAP 11	A118
EXSIX-○○○○R-○○	SHOULDER SIX	A133
EXSKS-○○○○R-○○	SKS EXTREME 09	A074
EXSKS-○○○○R-07-○○	SKS EXTREME 07	A072
EXSKS-○○○○R-05-○○	SKS EXTREME 05	A070
EZH5D○○○○S○○	EZ HARD DRILL	B003
EZH5D○○○○S○○-LS	EZ HARD DRILL	B003

F

FJVA4○○○S○○-R250	FUJI BARREL - Solid carbide endmill	A030
FRM-○○○-R○○	Insert for MIRROR RADIUS ENDMILL - RNM/MRX type	A163
FSW-2005H	Screw for BNM6, RNM6	A146, A158
FSW-2506H	Screw for BNM8, RNM8	A146, A158
FSW-3007H	Screw for BNM10, RNM10	A146, A148, A158, A160
FSW-3509H	Screw for BNM12, RNM12	A146, A148, A158, A160
FSW-4013H	Screw for BNM16, RNM16	A146, A148, A158, A160
FSW-5016H	Screw for BNM20, RNM20	A146~148, A159, A160
FSW-6020	Screw for BNM25, RNM25	A147, A148, A159, A160
FSW-8025S	Screw for BNM30, RNM30	A147, A148, A159, A160

G

GMX-○○○○-○○-S○○	QMMAX GII	A084
GMX-○○○○R-○○	QMMAX GII	A083

H

HDM-○○○○-○○R-○○	SUPER DIEMSTER	A177
HEP-○○○○R-○○-○○	HEPTA MILL	A186
HRM-○○○-R○○	Insert for MIRROR RADIUS ENDMILL - RNM/MRX type	A162

K

KRM-○○○-R10-BR○○	Insert for MIRROR BARREL - MRX type	A025
------------------	-------------------------------------	------

L

LRM-○○○-R○○-BR○○	Insert for MIRROR BARREL - MBX type	A028
------------------	-------------------------------------	------

INDEX

Cat.No	Name	Page
--------	------	------

M

M10×1.5×25	ARBOR SET BOLT for EXSKS09, HEP	A074, A186
M10×1.5×35	ARBOR SET BOLT for SKG	A050, A053
M12×1.75×30	ARBOR SET BOLT for SKG, EXSAP11, EXSAP17, EXSIX, SSV	A050, A053, A062, A118, A122, A133, A137
M12×1.75×35	ARBOR SET BOLT for EXSKS07	A072
M12×1.75×40	ARBOR SET BOLT for EXSKS09, HEP	A074, A186
M16×2×25	ARBOR SET BOLT for EXSAP17	A122
M16×2×30	ARBOR SET BOLT for EXSIX, SSV	A133, A137
M16×2×45	ARBOR SET BOLT for EXSKS09	A074
M20×2.5×40	ARBOR SET BOLT for EXSAP17, EXSIX, SSV	A122, A133, A137
M20×2.5×45	ARBOR SET BOLT for EXSKS09, HEP	A074, A186
MAGNETISER	MAGNETISER	A110
MAL-○○○○-M○○	AERO-CHIPPER	A193
MAM-○○○○-M○○	AERO-CHIPPER	A191
MBX-○○○-M○○	MIRROR BALL	A028, A148
MEX-○○○○-07-M○○	SKS EXTREME 07	A072
MEX-○○○○-05-M○○	SKS EXTREME 05	A070
MPM-○○○○-M○○	QMMILL	A109
MPT-○○○○A00-M○○	HIGH PRECISION QMMILL	A109
MQT-○○○○A00-M○○	HIGH PRECISION QMMAX	A031
MQX-○○○○-M○○	QMMAX	A095
MRX-○○○-M○○	MIRROR RADIUS	A025, A160
MSG-○○○○-09-M○○	SKS-GII 09	A064
MSG-○○○○-10-M○○	SKS-GII 10	A051
MSN-M○○-○○○-S○○C	MSN Carbide Modular Head Holder	A214
MSN-M○○-○○○S-○○C	MSN Carbide Modular Head Holder	A216
MSN-M○○-○○○T-○○C	MSN Carbide Modular Head Holder	A214
MSX-○○○○-11-M○○	EXTREME SAP 11	A120
MSX-○○○○-M○○	EXTREME SAP 17	A124
MTP-○○○-M○○	MIRROR BARREL	A026, A027
MXF-○○○○-M○○	DIEMASTER 5G	A171
MXG-○○○○-M○○	QMMAX GII	A085

P

PME○○○○S○○	QMMill	A108
PME○○○○S○○-LS	QMMill	A108

Q

QXPS○○○○S○○+A	QMMAX	A094
QXP-○○○○R	QMMAX	A093

Cat.No	Name	Page
--------	------	------

R

RD□T○○□○M□□	Insert for SUPER DIEMSTER - HDM/SDH type	A181
RD□T○○○○M□□	Insert for SUPER DIEMSTER - HDM/SDH type	A181
RDGT○○□○M○F-AL	Insert for SUPER DIEMSTER - HDM/SDH type	A182
RDGT○○○○M○F-AL	Insert for SUPER DIEMSTER - HDM/SDH type	A182
RDMT○○○○M○E-ML	Insert for SUPER DIEMSTER - HDM/SDH type	A181
RDMW○○□○M□□	Insert for SUPER DIEMSTER - HDM/SDH type	A181
RDMW○○○○M□□	Insert for SUPER DIEMSTER - HDM/SDH type	A181
RNM□-○○○○○○S-S○○C	MIRROR RADIUS ENDMILL	A158, A159
RNM□-○○○○○○T-S○○C	MIRROR RADIUS ENDMILL	A158, A159
RNM□-○○○○○○U-S○○C	MIRROR RADIUS ENDMILL	A158, A159
RNM-○○○-R○○	Insert for MIRROR RADIUS ENDMILL - RNM/MRX type	A161

S

SDET090312ZDER-SM	Insert for SKS-GII 09 type	A065
SDEW090312ZER	Insert for SKS-GII 09 type	A065
SDH-○○○○-R○○-M○○	SUPER DIEMSTER	A179
SEHH○○○○	ONE CUT 70 - Solid carbide endmill	C003
SEHH○○○○-R○○	ONE CUT 70 - Solid carbide endmill	C004, C005
SEHL○○○○	ONE CUT 70 - Solid carbide endmill	C007
SEHM○○○○	ONE CUT 70 - Solid carbide endmill	C006
SEHS○○○○	ONE CUT 70 - Solid carbide endmill	C003
SFSB○○○○	HARD 1 BALL - Solid carbide ball nose endmill	C021
SFSB○○○○-S6	HARD 1 BALL - Solid carbide ball nose endmill	C021
SFSR○○○○-R○○	HARD 1 RADIUS - Solid carbide radius endmill	C012
SFSR○○○○S○○-R○○-○○	HARD 1 RADIUS - Solid carbide radius endmill	C013
SFSR○○○○S○○-R02-○○	HARD 1 RADIUS - Solid carbide radius endmill	C014
SFSV○○○○S○○	CHAMFERING CUTTER - for Hard Materials	C029
SKG-○○○○-○○-09-S○○	SKS-GII 09	A063
SKG-○○○○R-09-○○	SKS-GII 09	A062
SKG-○○○○R-10-○○	SKS-GII 10	A050
SKG-○○○○R-14-○○	SKS-GII 14	A053
SMAL-○○○○-M○○	S HEAD - Solid carbide modular head	A208
SMHB-○○○○-M○○	S HEAD - Solid carbide modular head	A213
SMSA-○○○○R○○○○-M○○	S HEAD - Solid carbide modular head	A203
SMSR-○○○○R○○-M○○	S HEAD - Solid carbide modular head	A210
SPET100415ZPER-SM	Insert for SKS-GII 10 type	A052
SPMT100415ZP○R-PM	Insert for SKS-GII 10 type	A052
SPMT100415ZP○R-SM	Insert for SKS-GII 10 type	A052
SPMT140520ZP○R-PM	Insert for SKS-GII 14 type	A054
SPNW100415ZTR	Insert for SKS-GII 10 type	A052
SPNW140515ZTR	Insert for SKS-GII 14 type	A054
SSV-○○○○-○○○-S○○+A	SIC-EVO	A139
SSV-○○○○-M○○	SIC-EVO	A138
SSV-○○○○R-○○	SIC-EVO	A137
STLP-4○○○T○○○R-○○○	S HEAD - Solid carbide modular head	A029

INDEX

Cat.No	Name	Page
--------	------	------

T

TEZ○○○○	Insert for TA-EZ Drill - TEZD type	B027, B028
TEZD○○○○S○○-ML	TA-EZ Drill 5D	B025
TEZD○○○○S○○-MS	TA-EZ Drill 3D	B024
TEZD○○○○S○○-XL	TA-EZ Drill 8D	B026
TEZ○○○○S	Insert for TA-EZ Drill - TEZD type	B029
TLD3DCH○○○○S○○	FLAT Drill 3D	B010, B011
TLD5DCH○○○○S○○	FLAT Drill 5D	B012, B013
TLDM○○○	FLAT Drill 2D	B006, B007
TLDM○○○-S6	FLAT Drill 2D	B006
TLZ○○○○	Insert for TLZD Drill - TLZD type	B018
TLZD○○○○-M○	TLZD Drill	B017
TLZD○○○○S○○-SS	TLZD Drill	B016
TNM-○○○○-NR○BR○○	Insert for MIRROR BARREL - MTP type	A026
TPM-○○○-NR2T30BR○○○	Insert for MIRROR BARREL - MTP type	A027
TQC-○○	Torque Control Wrench	A153
TSW-2556H	Screw for MQT, QXPS, MQX, SDH, TLZD, TEZD	A031, A094, A095, A179, A180, B016~017, B024~026
TSW-2567H	Screw for GMX, MXG, TLZD, TEZD, MXF/XFG	A083~A085, B016~017, B024~026, A172
TSW-307H	Screw for EXSKS05, EXSAP11	A070~071, A118~120
TSW-3509H	Screw for SKG10	A050~051
TSW-3510H	Screw for TLZD, TEZD	B016~017, B024~026
TSW-3512H	Screw for SSE45, SSD90, TLZD, TEZD	B016~017, B024~026
TSW-410H	Screw for EXSKS07, EXSAP17, EXTDM	A072~073, A122~124

W

WNHU04T310ZER	Insert for DIEMASTER 5G - MXF/XFG type	A172
WNMU050320ZER-PM	Insert for SKS EXTREME - EXSKS 05 type	A071
WNMU070620ZER-PM	Insert for SKS EXTREME - EXSKS 07 type	A073
WNMU090720ZER-PM	Insert for SKS EXTREME - EXSKS 09 type	A075
WNMU090828ZER-PL	Insert for SKS EXTREME - EXSKS 09 type	A075

X

XDHW080610ZER-W	Insert for HEPTA MILL - HEP type	A187
XDMT080620ZER	Insert for HEPTA MILL - HEP type	A187
XDMT080620ZER-ML	Insert for HEPTA MILL - HEP type	A187
XDMW080620ZTR	Insert for HEPTA MILL - HEP type	A187
XDMW080635ZTR-S	Insert for HEPTA MILL - HEP type	A187
XFG-○○○○R-○○	DIEMASTER 5G	A171
XOET0803○○PDFR	Insert for AERO CHIPPER - AMX/MAM type	A192
XOGT1605○○PDR	Insert for AERO CHIPPER - ALX/MAL type	A194
XPH□100308ZER-R	Insert for HIGH PRECISION QM MAX - MQT type	A032

Y

YCMU0907○○ZER-PM	Insert for SHOULDER SIX - EXSIX type	A134
YOHW0602○○ZER-12	Insert for QM MILL - PME/PME-LS/MPM type	A110
YPHW1003○○ZER-15	Insert for QM MAX - MQX/QXP type	A032, A097
YPHW100308ZER-F	Insert for QM MAX - MQX/QXP type	A032, A097
YPHW100308ZTR-F1	Insert for QM MAX - MQX/QXP type	A032, A097
YPHW100320ZER-24	Insert for QM MAX - MQX/QXP type	A097

Cat.No	Name	Page
--------	------	------

Z

ZNGU1105○○ZER○○	Insert for EXTREME SAP - EXSAP 11/MSX 11 type	A121
ZNGU1709○○ZER○○	Insert for EXTREME SAP - EXSAP 17/MSX 17 type	A125
ZOET1605○○ZFR-NL	Insert for SIC-EVO - SSV type	A140
ZOMT0602○○ZER-PL	Insert for QM MILL - PME/PME-LS/MPM type	A110
ZOMT1605○○ZER-PM	Insert for SIC-EVO - SSV type	A140
ZPMT1003○○ZER-NL	Insert for QM MAX - MQX/QXP type	A097
ZPMT1003○○ZER-PL	Insert for QM MAX - MQX/QXP type	A097
ZPMT1003○○ZER-SL	Insert for QM MAX - MQX/QXP type	A097

PLANTS & OFFICES IN JAPAN



● OSAKA PLANT



● MIE POWDER PLANT (raw materials)



● MIE PLANT (carbide blanks)



● MIE PLANT (tools)



● TONDABAYASHI PLANT (raw materials)



Break Through



DIJET INDUSTRIAL CO., LTD.

Headquarters 2-1-18, Kami-Higashi, Hirano-ku, Osaka 547-0002, Japan Phone: 81-6-6791-6781 Fax: 81-6-6793-1221



DIJET GmbH (Europe)

Immermannstr.9 40210 Düsseldorf, Germany
Phone. 49-211-50088820, 50088822 Fax. 49-211-50088823

DIJET INDUSTRIAL CO., LTD. (Bangkok Representative Office)

699 Srinakarindr Road, Modernform Tower 15th Floor,
Kweang Suanluang, Khet Suanluang, Bangkok 10250, Thailand
Phone. 66-2-722-8258, 8259 Fax. 66-2-722-8260

DIJET INDUSTRIAL CO., LTD. (Shanghai Representative Office)

Room No.712 Tomson Commercial Building., 710 Dongfang Rd.,
Shanghai 200122, China
Phone. 86-21-5058-1698 Fax. 86-21-5058-1699

DIJET INDUSTRIAL CO., LTD. (Guandong Representative Office)

Rm.903, No.98, Zhenan East-Road, Changan Town, Dongguan City,
Guangdong Province 523850, China
Phone. 86-769-8188-6001 Fax. 86-769-8188-6608

DIJET INDUSTRIAL CO., LTD. (Chengdu Office)

RM.No.2015, No.1BLDG.A-B Stand, Hi-Tech Incubation Garden, No.1480
Tianfu Avenue North, Hi-Tech District, Chengdu City, Sichuan, P.R.CHINA
Phone. 86-28-8511-4585 Fax. 86-28-8511-2758

DIJET INDUSTRIAL CO., LTD. (Wuhan Office)

B-2513, Jiayu Jiayin Business Masion, No.10 Chuangye Road,
Wuhan Eco. & Tech. Development Zone, Wuhan City, Hubei 430056, China
Phone. 86-27-8773-8919 Fax. 86-27-8773-8959

DIJET INDUSTRIAL CO., LTD. (Mumbai Representative Office)

305, Mahant Chambers Plot No.315, Road No.34, Wagle Estate
MIDC Industrial Area, Thane (W),400604,India
Phone. 91-22-4012-1231 Fax.91-22-4024-0919

DIJET Incorporated (U.S.A.)

45807 Helm Street, Plymouth, MI 48170 U.S.A.
Phone. 1-734-454-9100 Fax. 1-734-454-9395